

# CITIZEN

---

# Scientific Calculator

---

**Model SR-135T**

**Instruction Manual**

## CONTENTS:

<b>1. FEATURES</b> . . . . .	<b>1</b>
<b>2. THE KEYBOARD AND OPERATING CONTROLS</b> . . . . .	<b>2</b>
<b>3. DISPLAY</b> . . . . .	<b>10</b>
<b>4. CALCULATION</b> . . . . .	<b>11</b>
1) Calculation order of priority . . . . .	11
2) Addition, Subtraction, Multiplication and Division Constant calculations . . . . .	11
3) Memory calculation . . . . .	12
4) Calculation with parenthesis . . . . .	13
5) Coordinate conversion . . . . .	13
6) Complex calculation . . . . .	14
7) Statistical calculation . . . . .	15
<b>5. SPECIFICATIONS</b> . . . . .	<b>16</b>
<b>6. AUTOMATIC POWER OFF</b> . . . . .	<b>16</b>
<b>7. REPLACING THE BATTERIES</b> . . . . .	<b>16</b>

### 1. FEATURES

- (1) Normal operations.  
Four operation (+, −,  $\times$ ,  $\div$ ),  $x^y$ ,  $\sqrt[y]{x}$ , auto-constant, parenthesis, percentage.
- (2) Memory calculation(X $\rightarrow$ M, MR, M+).
- (3) General mathematical function:

Trigonometric (3)	Arctigonometric (3)
Logarithmic (2)	Exponential (2)
Square	Power
Square Root	Cube Root
Root	$\pi$
Parenthesis	Reciprocal
EXP	+/-
SCI	Factorial
DEG, RAD, GRAD	Degree, minute, second conversion (2)
FIX	X $\leftrightarrow$ Y
RND	Coordinate conversion.
- (4) Binary, octal, decimal and hexadecimal mode.  
Mutual conversions and calculations of binary, octal, decimal, and hexadecimal numbers.
- (5) Memory protection when power off.
- (6) An automatic power off feature to preserve battery life.
- (7) Statistics calculations.
  - Number of sample (n).
  - Total of square of all data ( $\Sigma x^2$ ).
  - Average ( $\bar{x}$ ).
  - 2 kinds of the standard deviation ( $\sigma_{n-1}$ ,  $\sigma_n$ ).
  - Total of all data ( $\Sigma x$ ).
- (8) 2-variable function polar-rectangular coordinate conversion.

## 2. THE KEYBOARD AND OPERATING CONTROLS

<sup>SD</sup>  
(1) [ON/C] : 1. Power on and clear an error condition.  
2. Set and clear the statistics mode.

<sup>x!</sup>  
(2) [CE] : 1. Clear entry key.  
2. Factorial function (x!).  
 $x! = n \times (n-1) \times (n-2) \times (n-3) \times \dots \times 2 \times 1$

(3) [OFF] : Power off key.

(4) [SHIFT]: This is the key for specifying the second function. When this key is pressed, the special display "SHIFT" lights. When this key press twice continuously, the second function mode releases.

<sup>DRG.</sup>  
(5) [DRG] : a. Pressing this key will change the mode of angle unit sequentially  $\rightarrow$  DEG  $\rightarrow$  RAD  $\rightarrow$  GRAD  $\rightarrow$  and display it on LCD.

b. Pressing this key after [SHIFT] key shall change the mode of angle and shall convert the displayed data.

$$\text{DEG} \rightarrow \text{RAD} : \text{RAD} = \text{DEG} \times \pi/180$$

$$\text{RAD} \rightarrow \text{GRAD} : \text{GRAD} = \text{RAD} \times 200/\pi$$

$$\text{GRAD} \rightarrow \text{DEG} : \text{DEG} = \text{GRAD} \times 180/200$$

(6) [0] ~ [9] : Press these keys in their logical sequence to enter numbers.

<sup>RND</sup>  
(7) [•] : a. Use to set the decimal point when entering numbers.  
b. When press as the first number, it is regarded as [0] and [•] keys are pressed.  
c. Random as a second function.  
Pressing this key shall display the random number.  
The range of random number is 0.000~0.999.

(8) [+/-] : a. In setting data in the mantissa section, this key reverse code in the mantissa section similarly for exponent section, it reverse code in the exponent section.  
b. For the operation result, this key reverse code in the mantissa section.

(9) [+], [-], [x], [÷], [ ( ), [ ) ]

a. When the key operations are performed by these keys according to a numerical expression, a result of operation is obtained according to mathematical priorities. Priorities discriminated are:

1) 1-variable function.

2) Expression in "( )"; (The most inner expression has priority in case of multiple parenthesis)

3)  $x^y$ ,  $\sqrt[y]{x}$

4) x, ÷

5) +, -

b. Whenever the key is operated, the calculator discriminates the above priorities and holds the data and operation keys pending as required.

This pending action is possible up to 6 times, and 15 levels or more pending become error.

c. [ ( ) key is accepted only immediately after [CE], [+], [-], [x], [÷],  $[x^y]$ ,  $[\sqrt[y]{x}]$ , [=], [ ( ) keys can not accepted in all other cases.

When this key is accepted, the displayed data is cleared to 0. When [ ( ) key is first accepted, the special display " ) " illuminates.

When a parenthesis expression is completed [ ) ] and [=] key or When it is cleared by the [ON/C] key, etc. or when errors are generated, the special display "( )" goes out.

d. If it is within the allowable range of pending, [ ( ) can be input into any place in an expression as many times as desired.

However, if the key is pressed continuously 16 times or more, it becomes error.

e. From a viewpoint of numerical expression when the corresponding " ) " key is not pressed, the operation is not executed even if the " ( " key is pressed.

On the other hand, When the " ( " key is pressed and the " = " key is the pressed without pressing the corresponding " ) " key, the operation is also completed according to the priority.

(10) [X→M], [MR], [M+] Memory calculation

a. The memory register "M" used by these keys is a completely independent single memory.

b. Display data is added to "M" (memory register) by [M+] key. If data overflows at this time, the proceeding data is hold.

c. Display data is stored in "M" by [X→M] key.

d. Contents of "M" is displayed by [MR] key.

e. When any data except for 0 is stored in "M", the special display "M" illuminates.

(11)  $\pi$  [EXP] : 1. Exponent select key.

2. This key display a rounded value : 3.141592654.

(12) [=] : Calculation

a. When any arithmetic functions constant mode has been set, the displayed number is converted from a percentage to a decimal.

Example: 61.5%

Key Input	Display
[6] [1] [.] [5] [SHIFT] [%]	0.615

b. When [=] key is pressed after [%] following arithmetic function will be executed.

CALCULATION EXAMPLE	KEY OPERATION	LCD DISPLAY
WHAT IS 30% OF 450?	450 [x] 30 [SHIFT] [%] [=]	0.3 135.
WHAT PERCENTAGE OF 600 IS 120? ( $120 \div 600 \times 100 = 20$ )	120 [ $\div$ ] 600 [SHIFT] [%] [=]	6. 20.
WHAT 25% OF 400 IS AN EXTRA? ( $400 + (400 \times 25 / 100) = 500$ )	400 [+] 25 [SHIFT] [%] [=]	100. 500.
WHAT 25% OF 400 IS A DISCOUNT? ( $400 - (400 \times 25 / 100) = 300$ )	400 [-] 25 [SHIFT] [%] [=]	100. 300.

(13) Trigonometric and arctrigonometric function / Hyperbolic and arc hyperbolic trigonometric function (1-variable)  
([sin], [cos], [tan], [sin<sup>-1</sup>], [cos<sup>-1</sup>], [tan<sup>-1</sup>]).  
These function are calculated according to respective defined areas and accuracy shown in behind chart, any displayed result of operation can become operators.

(14) Exponential and Logarithmic functions (1-variable).  
([ln], [Log], [e<sup>x</sup>], [10<sup>x</sup>]) Same as Trigonometric functions.

(15) Reciprocal, Square, Square Root, and Cube Root.  
([1/x], [x<sup>2</sup>], [ $\sqrt{\quad}$ ], [ $\sqrt[3]{\quad}$ ]) same as Trigonometric functions.

(16) [→0, ”, ” →]: a. These keys convert degrees, minutes, seconds, into decimal degree and decimal degrees into degree minutes, and seconds.

b. On the "0, ”, ”" format, the integer part of display data is regarded as degree, 2 digits below the decimal point as minutes and the 3rd digit and belows as seconds.

Example:

2.11111111 [→0, ”, ”] [SHIFT][→0, ”, ”] <degree minute second>  
 2 06 3999  
 (39.99 seconds)

BIN

(17) Binary mode ([SHIFT], [ ÷ ], [0], [1]).

a. Data input and output are both binary integers in a maximum of 10 digits.

b. A negative number is expressed in binary of two's complement.

c. The range of internal operation is as shown below and if the result of the operation exceed the range, it becomes an error (overflow).

	Binary Number	Decimal Number
Outside the operation range	_____	512 ≤ DATA
Binary Positive Integer	11111111	511
	11111110	510
	11111101	509
	:	:
	:	:
	10	2
	1	1
0	0	
Binary Negative Integer (Complement)	11111111	-1
	11111110	-2
	11111101	-3
	:	:
	:	:
	100000001	-511
	100000000	-512
Outside the operation range		DATA ≤ -512

OCT

- (18) Octal mode ( [SHIFT], [ x ], [0] ~ [7] ).
- Data input and output are both octal integers with a maximum of 10 digits.
  - A negative number is expressed in the octal number display of two's complement.
  - The range of internal operation is as shown below and if the result of the operation exceed the range, it becomes an error (overflow).

	Octal Number	Decimal Number
Outside the operation range	—	536870912≤DATA
Octal Positive Integer	3777777777 3777777776 : : 1 0	536870911 536870910 : : 1 0
Octal Negative Integer (Complement)	7777777777 7777777776 111111101 : : : : 4000000001 4000000000	-1 -2 : : : : -536870911 -536870912
Outside the operation range		DATA≤-536870913

- (19) Hexadecimal Mode ([SHIFT], [HEX] , [0] ~ [9] , [A] ~ [F]).
- Data input and output are both hexadecimal integer with a maximum of 10 digits.
  - A negative number is expressed in a hexadecimal number of two's complement.
  - The range of internal operation is as shown below and if the result of operation exceed the range, it becomes an error (overflow).



- c. Input of 2 variable is performed by setting x or r pressing [a] key and y or  $\theta$  pressing [b] key.
- d. The operation result of x or r is obtained in the display register or by pressing [a] key and y or  $\theta$  by pressing [b] key.

	Input Data		Result	
	a	b	a	b
R→P (Rectangular→Polar)	x	y	r	$\theta$
P→R (Polar→Rectangular)	r	$\theta$	x	y

$$(\rightarrow r, \theta) \quad r = \sqrt{x^2 + y^2}, \quad \theta = \tan^{-1} y/x$$

$$(\rightarrow x, y) \quad x = r \cos \theta, \quad y = r \sin \theta$$

e. (R→P Conversion)

([x, y]→[r,  $\theta$ ])

Key operation

x

a

y

b

R→P

b

Display

x

x

y

y

r

$\theta$

f. (P→R Conversion)

([r,  $\theta$ ]→[x, y])

Key operation

$\theta$

b

r

a

P→R

b

Display

$\theta$

$\theta$

r

r

x

y

(23) Statistical calculation mode ([SHIFT] <sup>SD</sup>[ON/C]).

a. When you calculate the calculation of statistics, pressing [SHIFT]

<sup>SD</sup>[ON/C] keys for statistics mode ("SD" sign). When you clear to statistics mode, press the same keys ([SHIFT] <sup>SD</sup>[ON/C]).

b. You can't perform the memory calculation, parenthesis calculation or conversion of coordinates.

c. Data input are like this:

- data [x] individual [DATA]: on exist the plural units (in case of negative data, you have to use the [+/-] key)

d. [DATA]: Data entry key. [DEL]: Data clear key.

e. You can calculate the following statistical volume in this calculator.

1. n: Number of data (Number of sample).
2.  $\Sigma x$ : Total of datum.
3.  $\Sigma x^2$ : Total of square of each data.
4.  $\bar{x}$ : Average of datum.
5.  $\sigma_{n-1}$ : The sample standard deviation of the data.
6.  $\sigma_n$ : The population standard deviation of the data.

$$\bar{x} = \frac{\sum_{i=1}^n X_i}{n} = \frac{\Sigma x}{n}$$

$$\sigma_{n-1} = \sqrt{\frac{\sum_{i=1}^n (x_i - \bar{x})^2}{n-1}} = \sqrt{\frac{\Sigma x^2 - (\Sigma x)^2/n}{n-1}}$$

$$\sigma_n = \sqrt{\frac{\sum_{i=1}^n (x_i - \bar{x})^2}{n}} = \sqrt{\frac{\Sigma x^2 - (\Sigma x)^2/n}{n}}$$

CPLX

(24) [  $\blacktriangleright$  ]: Digit erase / Complex number mode key. When exponential portion is not specified:

[  $\blacktriangleright$  ] : Upon pressing this key immediately after the value is entered, displayed value is shifted to the right and the last digit is erased.

Example:	Entry	Display
	123456 $\rightarrow$	123456.
	[ $\blacktriangleright$ ] $\rightarrow$	12345.
	[ $\blacktriangleright$ ] [ $\blacktriangleright$ ] $\rightarrow$	123.
	456 $\rightarrow$	123456.

When exponential portion is entered: Numerals in exponential portion are shifted right and last digit is erased. At this point, 0 replaces the first digit in the exponential.

Example:	Entry	Display
	5 [EXP] 24 $\rightarrow$	5. 24
	[ $\blacktriangleright$ ] $\rightarrow$	5. 02
	[ $\blacktriangleright$ ] $\rightarrow$	5. 00
	42 $\rightarrow$	5. 42

[SHIFT] [CPLX] : Setting and clearing of complex number mode are executed alternately.

$\sqrt[y]{x}$

(25) [  $X^y$  ]: Power / Root key

[ $X^y$ ]: Press any number [X], [ $X^y$ ], any number [y], and [=] to raise y to the x power.

[SHIFT] [ $\sqrt[y]{x}$ ]: Press any number [x] [SHIFT] [ $\sqrt[y]{x}$ ], any number [y], and [=] to display the y root x.

### 3. DISPLAY

- Display style

0 123456789ABCDEF

- Special display

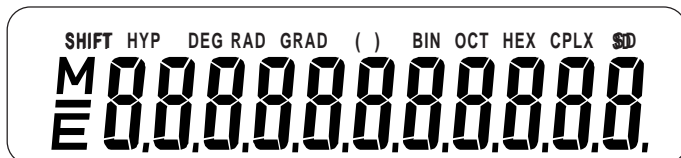

#### Examples of display

- Floating of -6000 1/x; FIX =7



- Same as above, engineering display

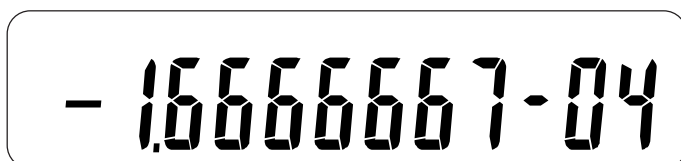

- Error display



## 4. CALCULATION

### 1. Calculation order of priority.

Because there is automatic priority of operations Logic the calculations, may be performed as expressed in the equation. (Calculation order of priority).

1. Function calculations.
2. Calculation in ( ).
3. Power and Root calculation.
4. Multiplication and division.
5. Addition and subtraction.

(Where the priority of two operations are the same they are performed in the order in which they appear).

Example:  $5 \div 4^2 \times 7 + 3 \times 0.5^{\cos 60^\circ} = 4.308820344$

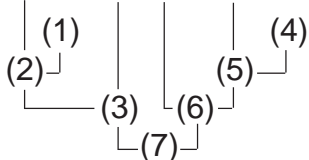

Key Input	Display
[5] [÷]	5.
[4] [x²]	16. .... (1)
[x]	0.3125 .... (2)
[7] [+]	2.1875 .... (3)
[3] [x]	3.
[•] [5] [xʸ]	0.5
[6] [0] [cos]	0.5 .... (4)
[=]	4.308820344 ..... (5)(6)(7)

- When execution starts with high priority calculations it is necessary to save low priority calculation, and for that reason there are 6 internal storage levels supplied.
- These storage levels are also used in calculations involving parenthesis, therefore as long as priority operations involving parenthesis do not exceed 15 levels the calculations may be performed as they appear in the equation.

### 2. Addition, subtraction, multiplication and division and constant calculations.

- The added in addition, subtracted in subtraction, multiplicand in multiplication, the divisor in division and the x value in power ( $x^y$ ) and Root ( $\sqrt[y]{x}$ ). Calculations takes on the value of constant.

Example:

1.  $123 + 456 =$
2.  $789 + 456 =$
3.  $123 - 456 =$
4.  $789 - 456 =$
5.  $123 \times 456 =$
6.  $123 \times 789 =$

7.  $123 \div 4 =$
8.  $456 \div 4 =$
9.  $7^4 =$
10.  $8^4 =$
11.  $\sqrt[5]{127} =$
12.  $\sqrt[5]{1024} =$

NO.	Key Input	Display
1.	[1] [2] [3] [+] [4] [5] [6] [=]	579.
2.	[7] [8] [9] [=]	1245.
3.	[1] [2] [3] [-] [4] [5] [6] [=]	- 333.
4.	[7] [8] [9] [=]	333.
5.	[1] [2] [3] [x] [4] [5] [6] [=]	56088.
6.	[7] [8] [9] [=]	97047.
7.	[1] [2] [3] [÷] [4] [=]	30.75
8.	[4] [5] [6] [=]	114.
9.	[7] [ $x^y$ ] [4] [=]	2401.
10.	[8] [=]	4096.
11.	[1] [2] [7] [SHIFT] [ $\sqrt[x]{y}$ ] [5] [=]	2.634879413
12.	[1] [0] [2] [4] [=]	4.

### 3. Memory calculation

Input and output the independent memory is done by pressing [X→M], [MR], [M+]

Example:

$$\begin{array}{r}
 123 \times 2 \\
 456 \times 3 \\
 789 \times 4 \\
 +) \quad 1470 \\
 \hline
 \end{array}$$

Total 6240

Key Input	Display
[ON/C] [X→M]	0.
[1] [2] [3] [x] [2] [M+]	M 246.
[4] [5] [6] [x] [3] [M+]	M 1368.
[7] [8] [9] [x] [4] [M+]	M 3156.
[1] [4] [7] [0] [M+]	M 1470.
[MR]	M 6240.

#### 4. Calculations with parenthesis.

- Parenthesis are used when it is desired to perform calculations in a first priority that usually followed for the +, -, x, ÷,  $x^y$ ,  $\sqrt[y]{x}$ , operations. In other words the “(” “)” force those prior operations it to be pending until the calculation inside the parenthesis are performed.
- Parenthesis may be used in a chained calculation as long as the total of levels ending due to the automatic priority Logic and parenthesis does not exceed 15.

Example:  $6 + [(5 - 3.6 + 5) \times 0.8 - 6] \times 3.2 =$

Key Input	Display
[6] [+][ ][ ][ ( ] [ ( ]	0.
[5] [-] [3] [·] [6] [+][5] [ ) ]	6.4
[x] [·] [8] [-] [6] [ ) ]	- 0.88
[x] [3] [·] [2] [=]	3.184

#### 5. Coordinate conversion:

(1) polar → rectangular

Example:

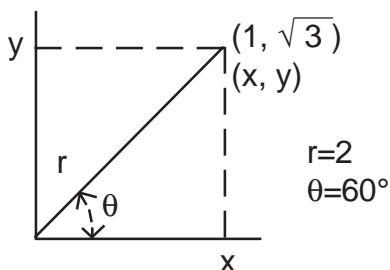

Key Input	Display
[2] [a]	2.
[60] [b]	60.
[SHIFT] [P→R]	1.
[b]	1.732050808

(2) rectangular → polar

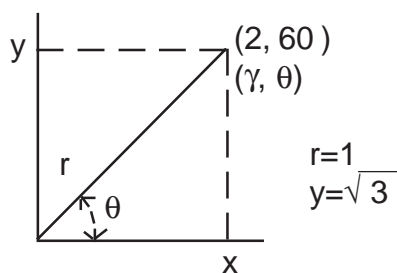

Key Input	Display
[1] [a]	1.
[3] [ $\sqrt{\quad}$ ] [b]	1.732050808
[SHIFT] [R→P]	2.
[b]	60.

## 6. Complex Calculation

EXAMPLE	KEY INPUT	DISPLAY	
$(5 + 4i) + (6 + 3i)$ $= 11 + 7i$	[SHIFT] [CPLX]	DEG	CPLX
	5 [a]	DEG	CPLX 0.
	4 [b]	DEG	CPLX 5.
	[+]	DEG	CPLX 4.
	6 [a]	DEG	CPLX 0.
	3 [b]	DEG	CPLX 6.
	[=]	DEG	CPLX 3.
	[b]	DEG	CPLX 11. 7.

EXAMPLE	KEY INPUT	DISPLAY	
$6 \times (7 - 9i) \times$ $(-5 \times 8i)$ $= 222 + 606i$	[ON/C]	DEG	CPLX
	6 [a] [x]	DEG	CPLX 0.
	7 [a] 9 [+/-] [b]	DEG	CPLX 0. -9.
	[x]	DEG	CPLX 0.
	5 [+/-] [a] 8 [b]	DEG	CPLX 8.
	[=]	DEG	CPLX 222.
	[b]	DEG	CPLX 606.

## 7. Statistical calculation.

Example:

(1) What is the average and standard deviation?

Data: 55, 53, 57, 54, 51, 56, 55, 52

Key Input	Display	Note
	SD	
[SHIFT] [SD]	0	set statistics mode
[5] [5] [DATA]	1	display the volume
[5] [3] [DATA]	2	of input data
[5] [7] [DATA]	3	
[5] [4] [DATA]	4	
[5] [1] [DATA]	5	
[5] [6] [DATA]	6	
[5] [5] [DATA]	7	
[5] [2] [DATA]	8	
[ $\bar{x}$ ]	54.125	Average of datum
[SHIFT] [ $\Sigma x$ ]	433	Total of datum
[SHIFT] [ $\Sigma x^2$ ]	23465	Total of square of datum
[n]	8	Number of input data
[ $\sigma_{n-1}$ ]	2.031009601	Standard deviation of samples ( $\sigma_{n-1}$ )
[ $x^2$ ]	4.125	Unbiased of variance
[SHIFT] [ $\sigma_n$ ]	1.899835519	Standard deviation of population ( $\sigma_n$ )
[SHIFT] [SD]	0	Clear the statistics mode ("SD" clear)

(2) Recorrect of data

Key Input	display	Note
[SHIFT] [SD]	0	Set statistics mode
[5] [0] [DATA]	1	
[6] [0] [DATA]	2	Input the incorrect data (60)
[6] [0] [SHIFT] [DEL]	1	Clear the incorrect data (60)
[5] [6] [DATA]	2	Input the correct data (56)
[5] [4] [x] [3] [DATA]	5	Input the incorrect data (54x3)
[5] [4] [x] [3] [SHIFT] [DEL]	2	Clear the incorrect data (54x3)
[5] [8] [x] [3] [DATA]	5	Input the correct data (58x3)
[5] [2] [x] [4] [DATA]	9	Input the incorrect data (52x4)
[5] [5] [DATA]	10	Input the correct data (55)
[5] [2] [x] [4] [SHIFT] [DEL]	6	Clear the incorrect data (52x4)
[SHIFT] [SD]	0	Clear the statistics mode ("SD" clear)

## 5. SPECIFICATIONS

Display capacity	: 10 digits full-floating or Mantissa 8 digits with Exponent 2 digits plus 2 negative code digits.
Components	: CMOS / LSI
Display	: Liquid crystal (FEM type)
Power supply	: 3V (DC) GP76Ax2 Approx. 1500 hours when used 2 hours a day.
Power consumption	: 0.15mw
Operation Temperature	: 0°C ~ 40°C (32°F ~ 104°F)
Size	: 141mm (L) x 76mm (W) x 9mm (H)
Weight	: 86g

## 6. AUTOMATIC POWER OFF

If any key is not pressed for about 7.5 minutes, the power is automatically shut off.

## 7. REPLACING THE BATTERIES

Your calculator is powered by two alkaline-manganese batteries. When the display dims, replace the batteries.

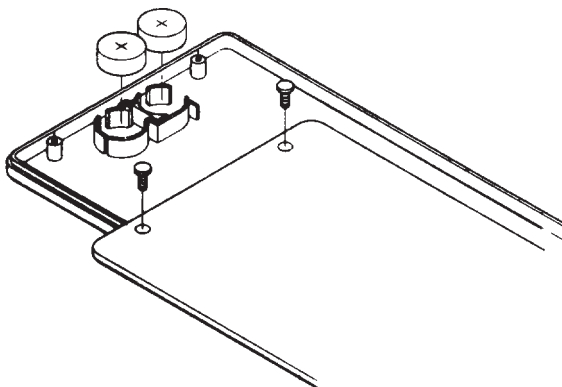

1. Unscrew the two screws on the back of the calculator.
2. Insert a flat bladed screwdriver into the slot between the upper and lower case then carefully twist it to separate the case.
3. Remove both batteries and dispose of them properly. Never allow children to play with batteries.
4. Wipe off the new batteries with a dry cloth to maintain good contact.
5. Insert the two new batteries with their flat sides (plus terminals) up.
6. Align the upper and lower cases then snap them to close together.
7. Tighten the screws.