

LINE THERMAL PRINTER MODEL CT-S2000L/CT-S2000DCL User's Manual

Refer to CT-S2000/CT-S2000DC User's Manual of standard model when reading this manual.

Contents

- 1.1 Features
- 4.6 Error Indications
- 5.3 Manual Setting of Memory Switch
- 5.4 Selecting Paper Type
- 5.5 Adjusting the Sensitivity of Paper Sensor
- 5.6 Printing Paper

CITIZEN SYSTEMS JAPAN CO., LTD.



CITIZEN is a registered trade mark of Citizen Holdings Co., Japan
CITIZEN es una marca registrada de Citizen Holdings Co., Japón
Company names and product names in this manual are trademarks or
registered trademarks of relevant companies.
Copyright © 2007 by CITIZEN SYSTEMS JAPAN CO., LTD.

1.1 Features

- High-speed printing at a maximum of 220 mm/s is possible (* 154 mm/s at standard density on label paper).
- Usable with label paper of 57.5 mm, 59.5 mm, and 79.5 mm wide other than 82.5 mm wide.
- Automatic adjustment of paper sensor sensitivity is available.

4.6 Error Indication

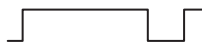
The following LED indications are added to CT-S2000L/CT-S2000DCL.

Status	POWER LED	ERROR LED	Buzzer
Wait for cutting label	OFF		—
Paper detection error	OFF		

5.3 Manual Setting of Memory Switch

Functions of memory switches SW4-1, SW4-2, SW4-4, SW4-5 and SW4-6 of CT-S2000L/CT-S2000DCL are as shown below. (The **white-on-black characters** are factory setting.)

Memory Switch	Function	0 (OFF)	1 (ON)
SW4-1	Paper Length Setting	Auto Measure	Command
SW4-2	Top of Form at Power ON	Invalid	Valid
SW4-4	Paper Select	Thermal Roll	BM.P/Lbl.P *
SW4-5	Position Detect	Black Mark	Label
SW4-6	Paper Change	Invalid	Valid

* When printing on label paper, adjust the layout so that right and left margins are 4 mm or more.

* The memory switch SW4-8 will be ignored for black mark paper.

* The memory switches SW2-8 and SW4-8 will be ignored for label.

5.4 Selecting Paper Type

Paper type selection is available by the combination of memory switches SW4-4 and SW4-5 by the used of "Memory Switch Select Mode". In addition, the following procedure is available.

1 Enter Selecting Paper Type mode.

- 1) Open the printer cover and remove paper. Pressing and holding the **FEED button**, turn the printer power ON. The POWER LED starts blinking.
- 2) Release the **FEED button** and then close the printer cover. Buzzer sounds and the paper type currently set is indicated by the LED on the operation panel.

2 Select Paper Type.

Press the **FEED button** to match the paper type loaded to the LED indications in the table below. (Refer to the table below.)

	POWER LED	ERROR LED
Label	Green lit	(OFF)
Thermal paper roll	(OFF)	Red lit
Black mark paper	Green lit	Red lit

3 Save the selected Paper Type to the Printer.

Open and close the printer cover. By this operation, selected paper type is stored in the printer memory and the Selecting Paper Type mode is terminated.

Since then, "P.Length Set" of Memory switch 4-1 becomes disable.

When closing the printer cover during the setting a black mark paper or label paper in the printer, paper length is measured, and the result will be printed out.

* When paper detection error occurs at the measurement of paper length, automatically enters paper sensor adjustment mode. Adjust the sensor in accordance with "5.5 Adjusting the Sensitivity of Paper Sensor".

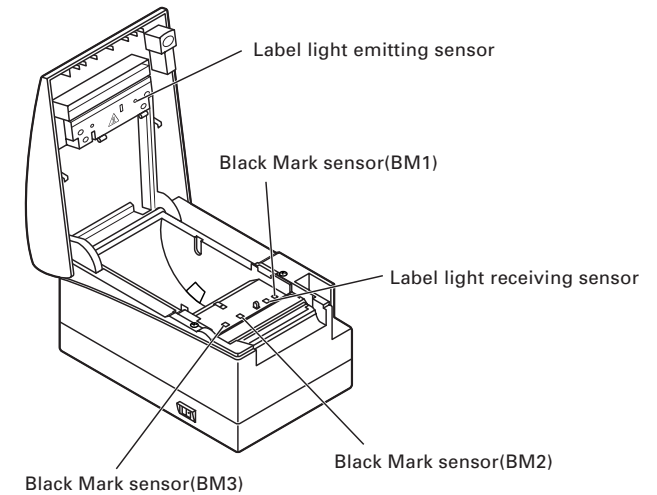

5.5 Adjusting the Sensitivity of Paper Sensor

Before using black mark paper (BM paper) or label paper, adjust the sensitivity of the paper sensor by using actual paper.

1 Enter Adjusting Paper Sensor mode.

Open the printer cover, remove paper, and then set the printer power switch to ON. Here, POWER LED and ERROR LED go on with the buzzer sound. Then close the printer cover while pressing the **FEED button**. The ERROR LED starts blinking with the buzzer sound.

2 Set paper to the printer.

This printer has three types of built-in paper sensors.

In case of label, set it so that label is positioned on the label light receiving sensor and label light emitting sensor. In case of black mark paper, set it so that the printable portion (other than black mark) is positioned on the black mark sensor. With this state kept, closing the printer cover causes ERROR LED to blink with the buzzer sound.

3 Adjust the sensitivity of the paper sensor and measure the length of paper.

Pressing the FEED switch causes label to be fed and paper sensor sensitivity adjustment and paper length measurement are carried out automatically. If the **FEED button** is pressed during the paper measuring, the result will be printed out as follows, and the printer memory switch will be initialized.

* The measuring result is a reference value



< Example of label measuring result >

5.6 Printing Paper

Also refer to the core dimension and notes of “5.2 Printing Paper” in User’s Manual of standard model. Use print paper shown in the following table or the equivalent.

Paper type	Product name
Recommended thermal label paper	GG40/P22/G6B from Ojitac, HD75 from Nippon Paper, 150LA-1 from Ricoh

a) Label paper

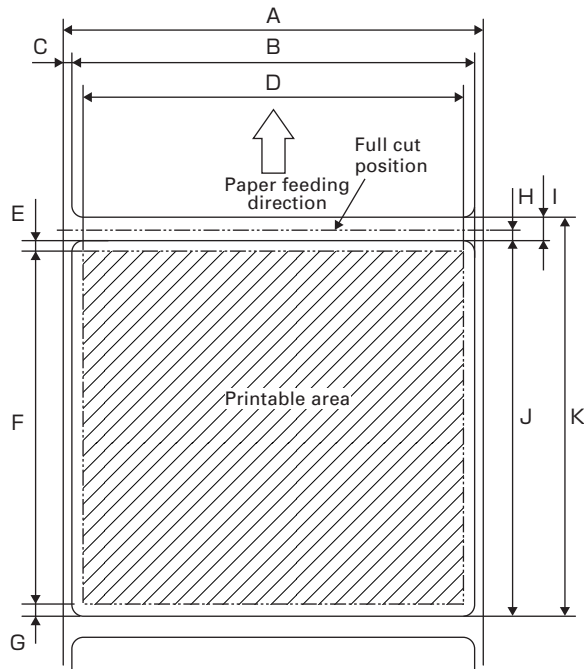

Unit: mm

Mark	Item	Dimensions
A	Liner width	57.5, 59.5, 79.5, 82.5 ± 0.5
B	Label width	(Size A) - 4 ± 0.5
C	Left edge of label	2 ± 0.5
D	Print width	(Size A) - 4
E	Top margin	2 ± 1
F	Print length	21 to 296
G	Bottom margin	2 ± 1
H	Cut position between labels	1/2 x (Size I)
I	Gap between labels	4 to 30
J	Label length	25 to 300
K	Label pitch	I+J

CAUTION!

Pay attention to the following when using Auto Cutter. Otherwise, a cutter lock or a cutter failure may occur.

- Set the cut length of paper to 25 mm or more.
- When using label paper, cut the gap between labels (liner sheet). Do not cut the label paper (tack paper).
- Adjusting the paper sensor must be carried when the type of liner is changed.

b) Black mark paper (BM paper)

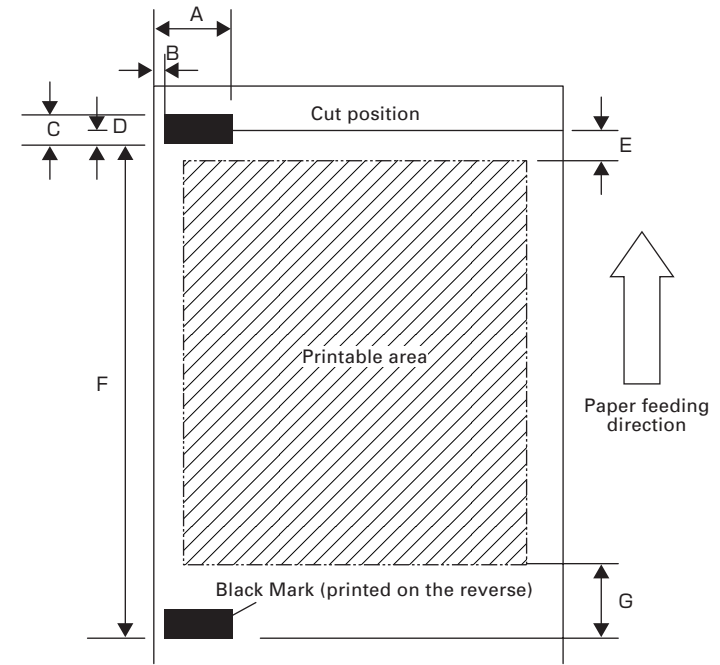

Unit: mm

Mark	Item	Dimensions		
		BM1	BM2	BM3
A	Right edge of black mark	13.5 or more	57.5 or more	80.5 or more
B	Left edge of black mark	15 or or less	15 or or less	15 or or less
C	Black mark height	5		
D	Cut position in black mark	2.5		
E	Top margin	6.5		
F	Black mark pitch	30 to 300		
G	Bottom margin	9		

CAUTION!

- PCS value of black mark must be 0.9 or more.
- When using the black mark paper, consider the margin of +/- 2 mm for the print position against the standard position and +/- 5 mm for print length.
- Refer to the above drawing for the printable area and have enough margins specified in the marks E and G. If the print data size is out of the printable area, the printer should skip to next page.

TA74912-00F

1.00E-0710

Printed in Japan