

CITIZEN

User's Manual

**DOT MATRIX PRINTER MECHANICAL
CONTROL LSI FOR DP910 SERIES**

MODEL CBM-909PC SERIES

Rev.1.00 Newly issued Sep.30th,2000

Japan CBM Corporation

CONTENTS

1. General Specifications	1
1.1 LSI Package	1
1.2 LSI Type	1
1.3 Printing functions	1
1.4 Control functions	2
1.5 Operating voltage	2
1.6 Oscillation frequency	2
2. Electrical Characteristics	3
2.1 Absolute maximum ratings	3
2.2 Operating range	3
2.3 Characteristics of LSI	4
2.4 Pin configurations	5
3. Description of signals	8
3.1 Description of control signals	8
3.2 Description of communication signals	14
3.3 Description of printer control signals	17
3.4 Description of control functions	18
4. Control commands	19
4.1 Print command	19
4.2 Cancel command	19
4.3 Enlarged character	19
4.4 Power down control	19
4.5 ESC control	23
5. Character code table	24
5.1 International character codes	24
5.2 Japanese character codes	26

The CBM-909PC Series Control LSI is intended for driving the mechanism of DP910 series printer.

TYPE

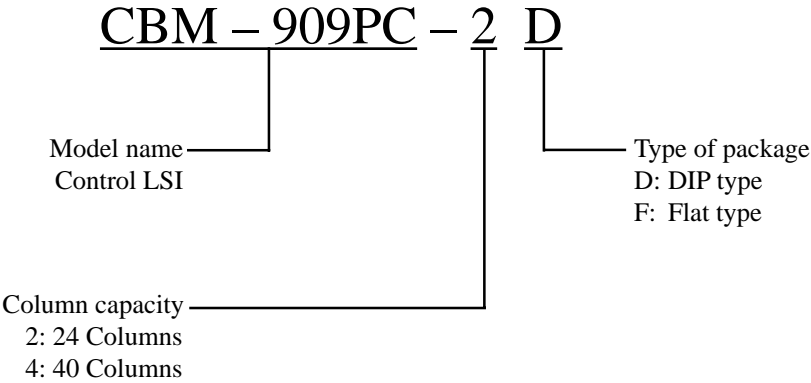

1. GENERAL SPECIFICATIONS

1.1 LSI Package

- 1) D type: 42 pin plastic Shrink DIP
- 2) F type: 44 pin plastic QFP

1.2 LSI Type

C-MOS LSI

1.3 Printing Functions

Mechanism of the DP-910 series

- 1) Printing system: Mechanical dot matrix
- 2) Printer specifications:

Model	Digits	Printing Speed	Control Board
MD-910	24	2.5 l/s	CBM-909-2XX
MD-911	40	1.8 l/s	CBM-909-4XX

- 3) Types of characters

	Japanese	International	24 Digits	40 Digits *
JIS 128 CH.	○		5 x 8 dots	7 x 8 dots
ASCII (C) 64 CH.		○	5 x 8 dots	7 x 8 dots
ASCII (\$) 32 CH.	○	○	5 x 8 dots	7 x 8 dots
Graphic 32 CH.	○	○	6 x 8 dots	7 x 8 dots
Ext. char. registration 8 CH	○	○	6 x 8 dots	7 x 8 dots

* Half dot included.

- 4) Line space: 2 dots, 1/36 inch (at initial setting)
- 5) Printing direction: L-type/R-type selectable
L-type=From the left to the right, R-type=From the right to the left
- 6) Bit image printing: The data subsequent to a bit image command is printed in the bit image mode.

1.4 Control functions

- 1) Paper feed function
- 2) Self printing function
- 3) Buffer-full automatic printing function
- 4) Emergency stop function
- 5) Control codes

Print command: CR or LF

Input data cancel: CAN

Enlarged character printing: Double (transverse direction)

International character printing: 32 characters

Bit image printing: ESC + K + n1 + n2 + n3

External character registration function: 8 characters at maximum

Line space setting: Even number of lines out of 4 to 255 dot lines

Power-down function: DC2, DC3

Paper feed command: (ESC + B + n, $4 \leq n \leq 255$)

1.5 Operating Voltage

- 1) Voltage: VDD=4.5 to 6.0 V DC at operating
VDD=3.5 to 6.0 V DC at low speed mode.*1

*1 The LSI is operated at low speed mode for first 60 ms after resetting the system.

- 2) Current:
VDD=5.0 V
At operating : 2.5 mA (typ.)
At power-down : DC2 0.5 mA (typ.)
At power-down : DC3 0.5 uA (typ.)

1.6 Oscillation frequency

4.19 MHz $\pm 0.5\%$

2. Electrical Characteristics

2.1 Absolute maximum ratings (Ta=25°C)

Item	Symbol	Test condition	Ratings	Unit
Power Supply	VDD	Ta = 25°C	-0.3~7.0	V
Input Voltage *1	Vi	Ta = 25°C	-0.3~VDD+0.3	V
Storage temperature	Tstg.	—	-65~150	°C

2.2 Operating Range

Item	Symbol	Test condition	Ratings	Unit
Power Supply	VDD	Operating low speed mode	4.5~6.0	V
			3.5~6.0 *2	V
Operating temperature	Top	—	-40~85	°C

Note)

- *1. If the input voltage exceeds a rated value, malfunctioning results, and in the worst case, the IC may be destroyed. At power-on time, do not apply an input signal prior to VDD.
- *2 Under regular operations it will operate in the high speed mode between the range of 4.5-6.0 V
Before moving on to the normal operations after the power down or power on function, it will operate in low speed between the 60 ms and operates between 3.5 and 6.0 V.

Ensure that an input signal is not input before the VDD when turning on the power. If the input signal should come first, then add an electric current limited resistance (1k-ohm) in the series with the input ports.

2.3 Characteristics of LSI

($T_a = -40 \sim 85^\circ\text{C}$, $V_{DD} = 3.5 \sim 6.0\text{ V}$)

Item	Sym.	Test condition		MIN	Typ	MAX	Unit
“H” Input Voltage	VIH	Port		0.8 VDD		VDD	V
		x1, x2		VDD - 0.5		VDD	
“L” Input Voltage	VIL	Port		0		0.2 VDD	V
		x1, x2		0		0.4	
“H” Output Voltage	VOH	Port VDD = 4.5 ~ 6.0 V	IOH = -1 mA	VDD - 1.0			V
			IOH = -100 μA	VDD - 0.5			
“L” Output Voltage	VOL	Port VDD = 4.5 ~ 6.0 V	IOL = 1.6 mA			0.4	V
			IOL = 400 μA			0.5	
“H” Input Leakage Current	ILIH	Port. VIN = VDD				3	μA
“L” Input Leakage Current	ILIL	Port. VIN = 0 V				-3	μA
“H” Output Leakage Current	ILOH	Port. VOUT = VDD				3	μA
“H” Output Leakage Current	ILOL	Port. VOUT = 0 V				-3	μA
Built-in pull-up Resistance *2	RL	Port	VDD = 5.0V $\pm 10\%$	15	40	80	k Ω
			VDD = 3.0V $\pm 10\%$	30		300	
Current	IDD *1	f = 4.19 MHz VDD = 5.0V $\pm 10\%$ At operating Halt mode			2.5 500	8.0 1500	mA μA
		VDD = 5.0V $\pm 10\%$ Stop mode			0.5	20	μA

Note)

*1. The IDD current is not included the current through the built-in pull-up resistance.

*2. At operating, the pull-up resistance in ports P10~P13, P20~P23, P30~P33, P60~P63, P70~P73 and P80~P81, will be set.

At power-down mode, the pull-up resistance in ports P20~P23, P30~P33, P60~P63 and P70~P73 will be set. Ports P40~P43, and P50~P53 are not built in pull-up resistance.

2.4 Pin configurations (Top View)

a) 42 Pin plastic shrink DIP

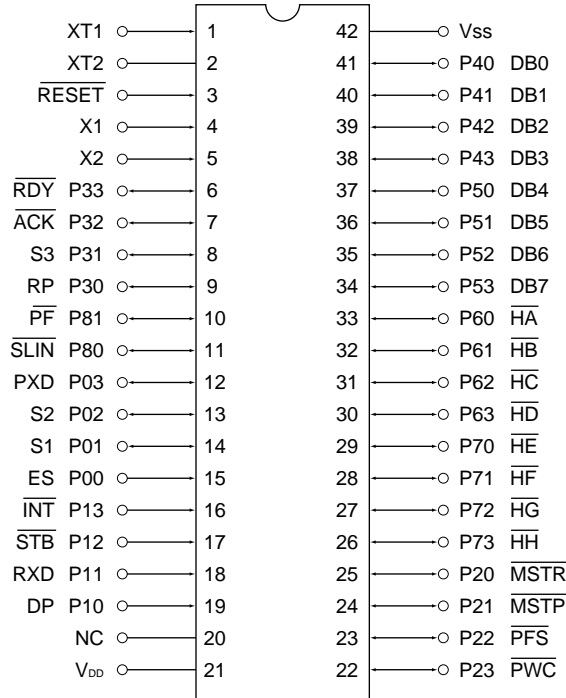

b) 44 Pin plastic QFP

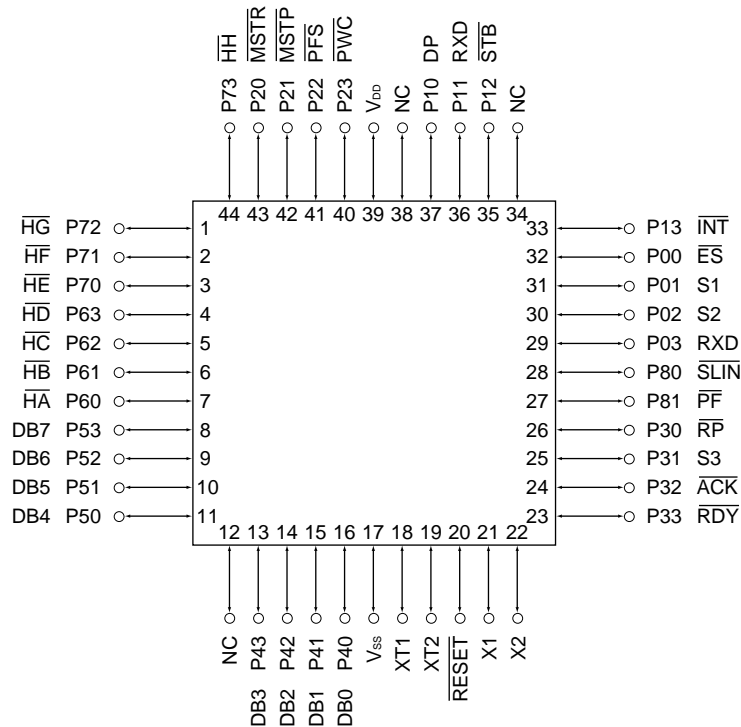

c) Pin Assignment

Pin No.		Symbol	Signal		Function
QFP	DIP		IN	OUT	
18	1	XT1			Connect to VDD or VSS.
19	2	XT2			Not use
20	3	Reset	○		System reset signal. If this signal is set to the Low level, the inside of the LSI is initialized.
21	4	X1	○		Oscillator terminals. 4.19 MHz \pm 0.5%
22	5	X2	○		
23	6	RDY		○	If receivable at data transfer time, this signal is set to the Low level.
24	7	ACK		○	If data read is completed at parallel data receive time, the Low pulse is output.
25	8	S3	○		Function selection S3.
26	9	RP	○		RP Signal from the printer.
27	10	RF	○		Paper feed signal. Effective only in the off-line mode.
28	11	SLIN	○		On-line setting signal. When this signal is at the Low level, the on-line mode is selected to enable data transfer. When this signal is at the High level, the off-line mode is selected to disable data transfer.
29	12	RXD	○		Serial transfer. Serial data input pin.
30	13	S2	○	○	Function selection S2 * 1
31	14	S1	○	○	Function selection S1 * 1
32	15	ES	○		Power-down command signal. If this signal is set to the Low level, control is interrupted and oscillation stops, resulting in the power-down mode.
33	16	INT	○		Power-down reset signal. If this signal is set to the Low level, the power-down mode is reset.
35	17	STB	○		Strobe pulse input Negative logic "Low"=8-bit data read
36	18	RXD	○		DIP type: Connect to 12 PIN QFP type: Connect to 29 PIN
37	19	DP	○		DP signal from the printer

Pin No.		Symbol	Signal		Function
QFP	DIP		IN	OUT	
38	20				NC
39	21	VDD			Power
40	22	PWC		○	The DC-DC converter control signal.
41	23	PFS		○	PF Solenoid signal.
42	24	MSTP		○	Motor brake signal.
43	25	MSTR		○	Motor drive signal.
44	26	HH		○	Print solenoid drive signals.
1	27	HG		○	
2	28	HF		○	
3	29	HE		○	
4	30	HD		○	
5	31	HC		○	
6	32	HB		○	
7	33	HA		○	
8	34	DB7	○		Parallel data (8 bits) Positive logic "High"="1" "Low"="0"
9	35	DB6	○		
10	36	DB5	○		
11	37	DB4	○		
13	38	DB3	○		
14	39	DB2	○		
15	40	DB1	○		
16	41	DB0	○		
17	42	VSS			GND
12					NC
34					

3. Description of signals

3.1 Description of control signals

1. RESET

The LSI is initialized by setting the reset pin at the low level. The reset pulse is required to be 10 μ S or more, while the LSI is operating. When the power is switched on, if using the ceramic oscillator, send the low level signal for 4 ms through the reset pin.

However, unless oscillation is stabilized, it is necessary to set the reset pin to the low level. After oscillation is stabilized, set the reset pin to the high level.

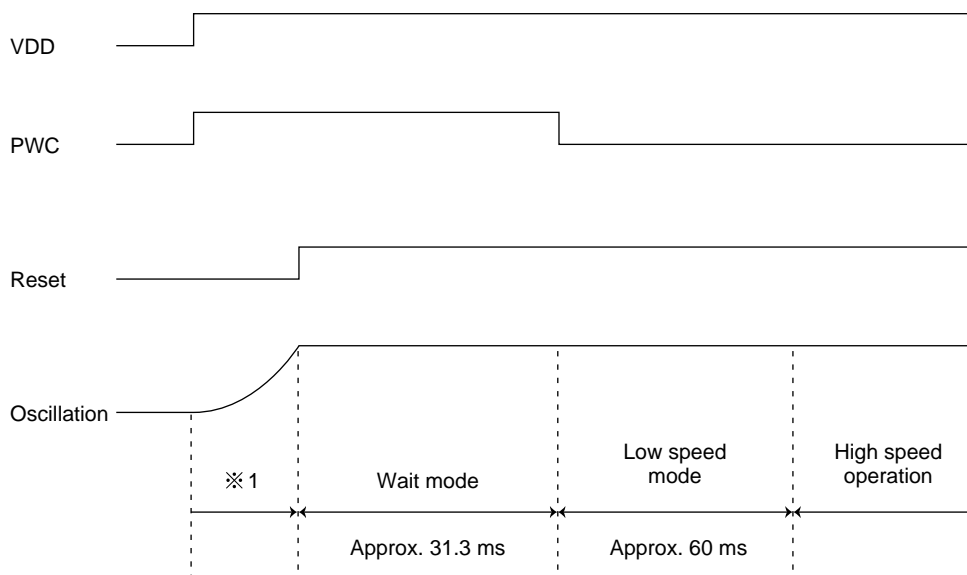

※1 It is necessary to secure an oscillation stabilization time (4 ms or more).

Resetting the stop mode

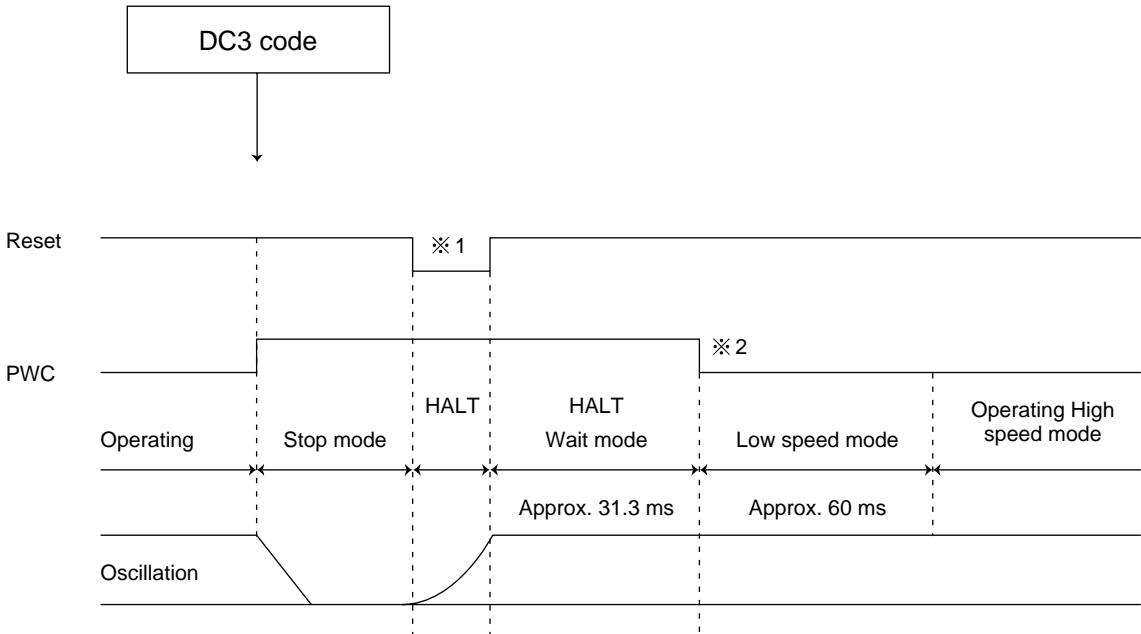

*2) At low speed mode, power source range of 3.5~6.0 V, activate the DC-DC converter with the PWC signal and supply the LSI with a voltage between 4.5~6.0 V. As a result, you will obtain the operation voltage range between 3.5~6.0 V.

Resetting the halt mode

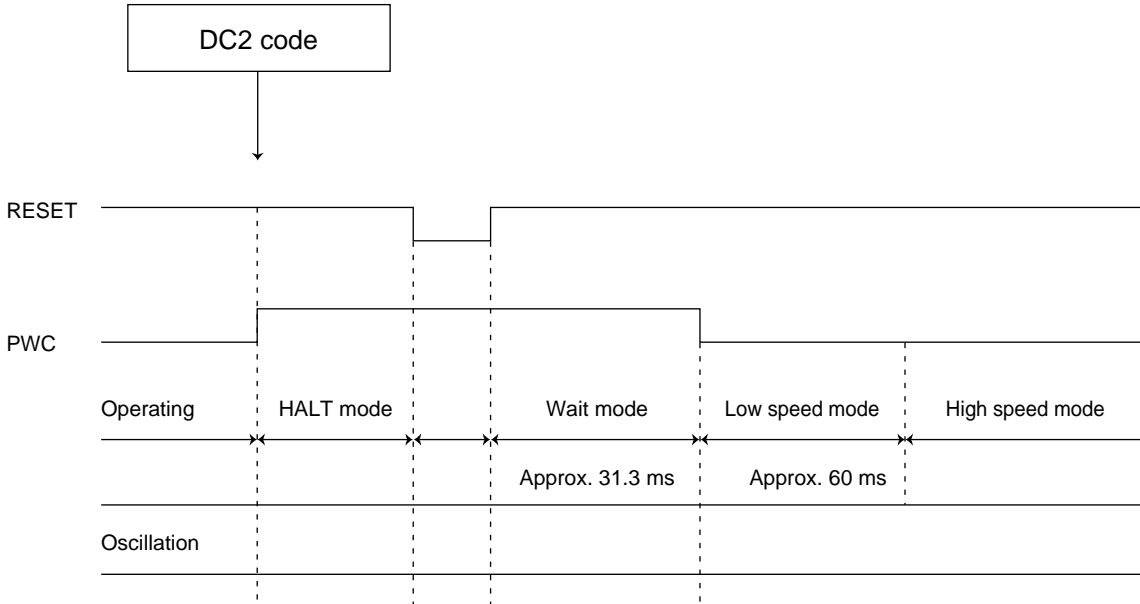

2. PWC

This terminal will be in the "LOW" level under the low-speed operation mode (60 ms) and normal operation mode. It will be in the "HIGH" level during power down.

By controlling (Refer to the circuitry diagram on p. XX, item XX) the DC-DC converter with the PWC signal, an operation voltage range between 3.5-6.0 V can be obtained.

3. SLIN

Setting the SLIN pin to the Low level places this system in the on-line mode and causes it to be ready to receive the data.

When this SLIN is at the High level, the system is placed in the off-line mode and can not receive the data. At this time, it receives the signal PF (paper feed).

This system samples the SLIN signal in the following cases.

- After completing a system reset
 - After resetting the power-down mode
 - While the data is ready
 - While the paper is being fed
- When the SLIN signal is set to Low during paper feed by the PF signal, the system is placed in the on-line mode after completing that feed.
 - When the SLIN signal is set to High during the text mode, the system is placed in the off-line mode after printing the data in the print buffer.
 - When the SLIN signal is set to High during the bit image mode, the data in the print buffer is cleared and the bit image mode is also reset.

4. PF

This is a manual paper feed pin and doubles as a self test printing pin.

This pin accepts a signal only when the system is in the off-line mode, except the power-down mode.

Line feed is performed while this pin is held at the Low level (30 ms or more). To conduct a self printing test, set the PF pin to the Low level and turn on the power or input the RESET signal.

5. INT

This is used to reset the power-down mode by the DC2 and DC3 command.

- Resetting the power-down mode by the DC2 command.
This is done by setting the INT pin to the Low level for 10 μ s or more.
- Resetting the power-down mode by the DC3 command.
This is done by holding the INT pin at the Low level until XTAL oscillation is stabilized, and then, by setting the pin to the High level.

6. ES

Setting this pin to the Low level interrupts system control and stops oscillation, resulting in the power-down mode.

Resetting the power-down mode by the ES signal. This is done by holding the ES pin at the high level and inputting the RESET signal.

7. S1, S2, S3

Function Setting DIP switch.

Symbol	Function	OFF	ON
S1	Data transfer method	Serial	Parallel
S2	Printing method	L-type	R-type
S3	Print command at parallel	CR	LF
	Baud rate at serial	9,600 bps	4,800 bps

- 1) The S1 and S2 terminals will be used as an input-port at initializing and an output-port at normally operating. Therefore add a resistance (10 kΩ~47 kΩ) between the S1, S2 terminals and the DIP switch, and then add a pull-up resistance (100 kΩ~150 kΩ) as shown below.

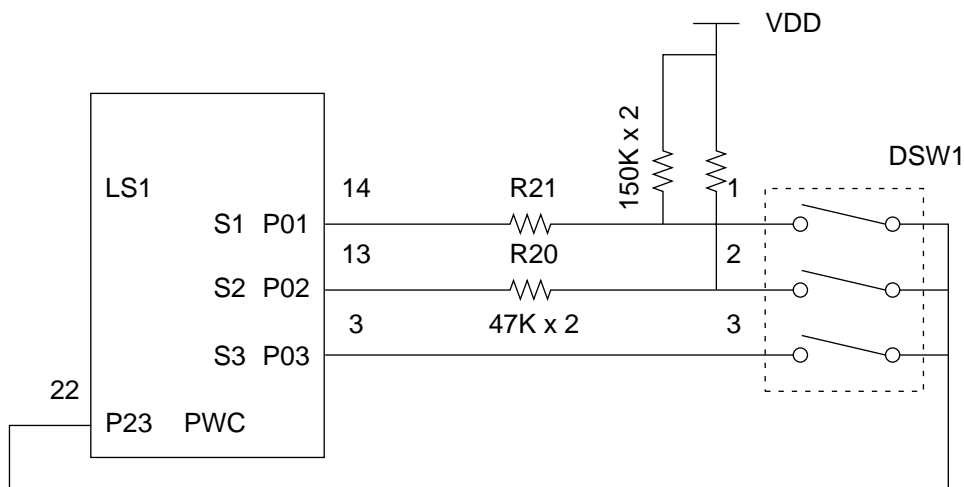

- 2) Printing method
Printing method is specified by setting DIP switch S2.
For bit image printing, inverted printing is not performed even if R-TYPE is specified.

L-TYPE

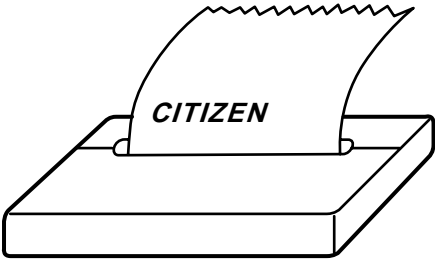

R-TYPE

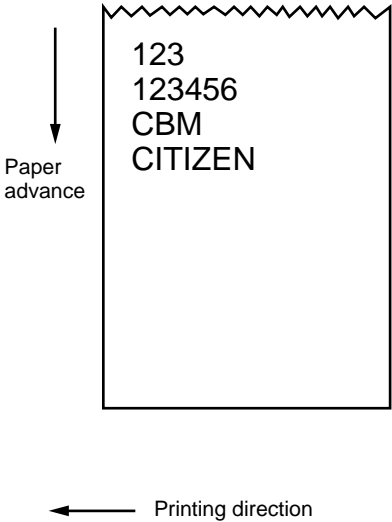
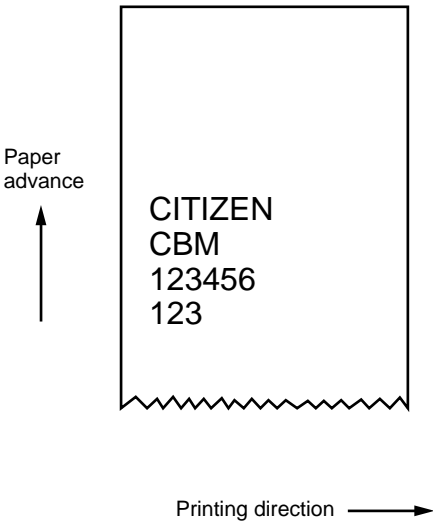
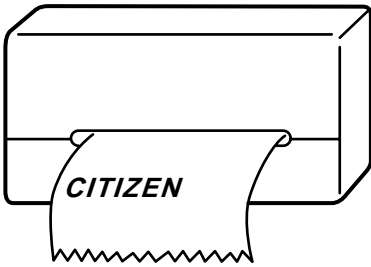

8. X1, X2

Use a ceramic oscillator for the clock of this LSI.
The oscillation frequency must be range $4.19 \text{ MHz} \pm 0.5\%$.
Recommended oscillator parts are the following.

Maker	Type	f	Capacitor		Operating Voltage
			C1	C2	
MURATA M.F.G	CSA 4.19 MGU	$4.19 \text{ MHz} \pm 0.5\%$	30PF	30PF	2.7 ~ 6.0 V
	CSA 4.19 MG		30PF	30PF	3.0 ~ 6.0 V

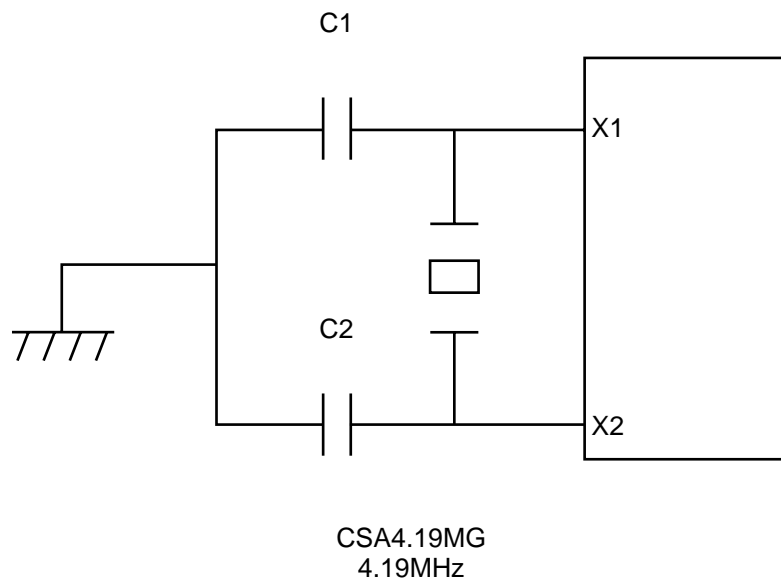

9. Others

XT1 and XT2 are the input terminals when using an external clock. However, this LSI is set to use X1 and X2. Please refrain from using terminal XT2 and connect terminal XT1 to V_{SS} (GND).
The connect terminal NC is not connected to the inside of the LSI.

3.2 Description of communication signals

1. DB0~DB7

These are parallel 8 bit data receive pins. For more details on the timing of the parallel data reception, refer to the time chart 3.2-6.

When the SLIN is setting the low level and the RDY outputs low level, the 8 bit data is latched by the STB signal (low level).

However, until the ACK pulse is output, hold the STB to low level.

2. RXD

This is the input pin to receive the serial data.

Refer to the timing chart 3.2-7.

When the RDY terminal is in the "LOW" level during the on-line status, the serial data from the host computer can be received via this terminal.

This incorporates a data buffer for one line.

Every time a line is printed the motor will stop, however when data transmission of the next line is finished while the printing head is returning it can undergo continuous printing without stopping the motor.

3. RDY

This terminal is used for parallel and serial data receptions.

The signals received when the RDY signal is on-line notifies the host that the LSI data can be received.

When Using With a Parallel Interface

After verifying that the RDY signal of the host is in the "LOW" level, there is a need to output data DB0-DB7 and output the STB terminal in "LOW" level.

This LSI will maintain the RDY signal at the "HIGH" level after verifying that the STB terminal is in "LOW" level.

However, the data read-in is not completed at this time. The data read-in of the LSI is completed only when an ACK pulse is output.

When Using With a Serial Interface

After verifying that the RDY signal of the host side is in "LOW" level, there is a need to put the RXD signals in the "LOW" level to perform data communication immediately after.

The RDY terminal is in the "HIGH" level under the following conditions.

- a) during power down
- b) during off-line
- c) during data read-in
- d) during printing

What is more, the RDY terminal during system reset will be in the floating status.

4. STB

This is a terminal used during parallel data reception and to input the data set signals from the host.

For the LSI to output signal level of this terminal it must be in the on-line status and the RDY signal must be in the "LOW" level. If the STB terminal is in "LOW" level, the LSI will consider that the data is sent from the host via the DB0-DB7 and start reading the data after the RDY terminal is switched to the "HIGH" level.

When the LSI completes the data read-in it will output an ACK pulse.

There is a need to keep the STB terminal in the "LOW" level until the startup of the ACK signal at the host is verified.

5. ACK

This is the data read-in signal used during parallel data reception.

During parallel data reception this terminal is in the on-line status and after outputting the RDY signal it will verify that the STB terminal is in the "LOW" level.

Then it will output a "LOW" pulse of about 2 μ s as a read-in timing signal to input the data in the terminal.

Therefore, there is a need for the data to be stable between, before and after these pulses.

6. Parallel interface timing chart

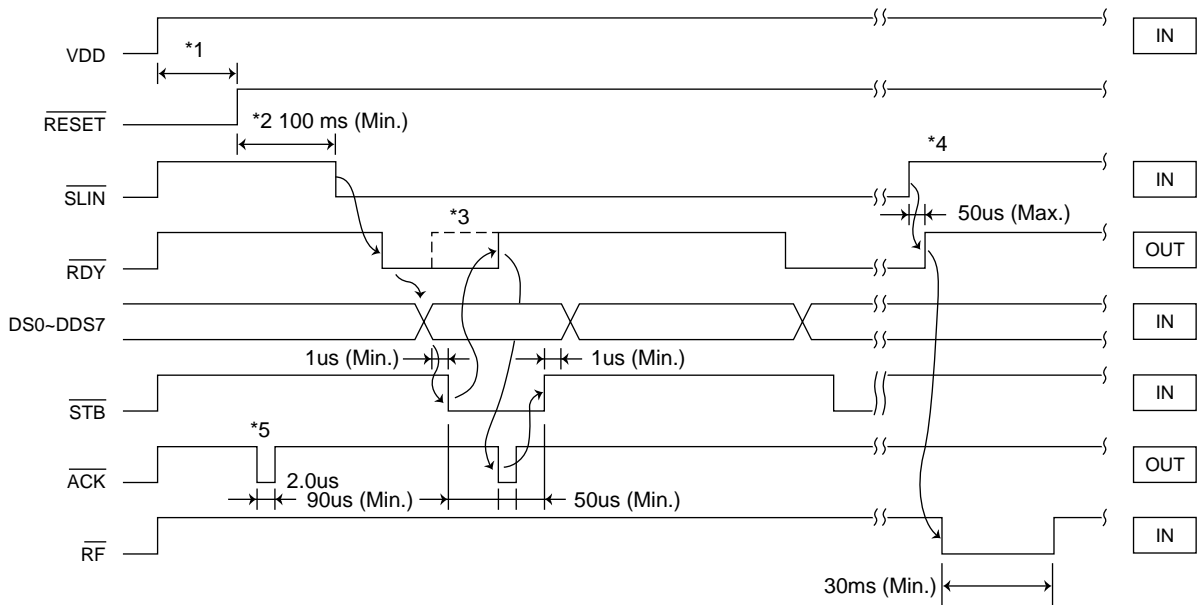

*1 It is necessary to secure an oscillation frequency stabilization time.

*2 Time required for the LSI to make the SLIN pin sensible after resetting the system.

*3 Since the DTR signal may rise regardless of the STB signal due to printer control, it is necessary to output the STB signal within 200 μ s after checking the DTR signal.

*4 After this, paper feed is enabled via the PF pin.

*5 The ACK signal is output by 1 pulse after resetting the LSI.

7. Serial interface timing chart

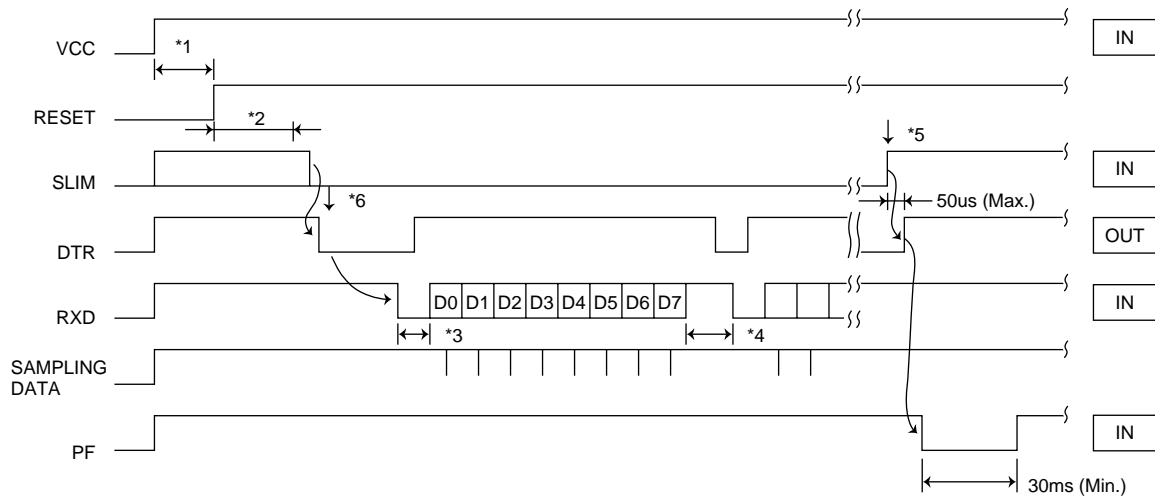

*1 It is necessary to secure an oscillation frequency stabilization time.

*2 Time required for the LSI to make the SLIN pin sensible after resetting the system.

*3 The number of start bits should be 1 bit.

*4 The number of stop bits should be 1 bit or more.

*5 After this, paper feed is enabled via the PF pin.

*6 The DTR signal may rise regardless of the RXD signal due to printer control. When transferring the data, therefore, it is necessary to set the RXD signal to the Low level within 200 μs after checking the DTR signal, and then, transfer the data.

3.4 Description of control functions

1. Buffer full automatic print

When the input buffer is filled up by the character data, it starts the printing automatically.

2. Self test printing

This LSI has a built in self print function.

Take the following procedures to test.

- a) Set the paper properly.
- b) Turn off the power switch.
- c) Turn on the power switch while keeping the PF signal to the low level, then set it to the high level.
- d) To stop the printing, turn off the power switch or set RESET signal to low level.

3. Emergency Stop Function

When the following abnormalities are detected during the print operation, cut off the power to the print head solenoids and motor, and put the LSI in the power down mode.

The emergency stop can be cleared by resetting the LSI.

Printer abnormalities are as follows.

- a) Motor lock.
- b) Operation defect in the timing detector (DP signal)
- c) Operation defect in the reset detector (RP signal)

4 CONTROL COMMANDS

4.1 Print commands: CR (0DH), LF (0AH)

When the parallel interface is used, either CR or LF code can be selected by preset (S3). If the set CR or LF code is input, the data in the print buffer is printed and line feed is performed.

When the serial interface is used, only the CR code becomes effective regardless of preset (S3).

When graphic mosaic printing is performed, line feed is not performed by the print command, and graphic mosaic printing is allowed on the next line.

4.2 Cancel command: CAN (18H)

This code cancels all the data on the identical line in the print buffer, which was input before the code is input.

4.3 Enlarged character printing: SO (0EH)

The printing data following this code is printed with its width doubled.

This function is cleared by the print command (CR LF) or DC4 (14H).

4.4 Power-down control: DC2 (12H), DC3 (13H)

There are two kinds of power-down mode, DC2 and DC3 codes, in order to reduce current consumption. If this code is received, the power-down mode is put into effect after printing the data received before it.

a. DC2 (12H)

Inputting the DC2 code places this unit in the power-down mode.

At this time, oscillation of the oscillator does not stop.

[Resetting the power-down mode]

a-1) Input to INT

If the Low pulse is applied to the INT pin for 10 μ s or more, the condition existing just before power-down is restored in about 100 ms and allows you to control the printer and transfer the data.

a-2) Input to RESET

If the Low pulse is applied to the RESET pin for 4 ms or more, the power-down mode is reset and the inside of the unit is initialized to be ready to operate in about 100 ms.

b. DC3 (13H)

Inputting the DC2 code places this unit in the power-down mode.

At this time, oscillation of the oscillator stops. Therefore, current consumption is much less than the DC2 power-down mode.

[Resetting the power-down mode]

b-1) Input to INT

If the Low level is applied to the INT pin for 10 μ s, the power-down mode is reset, and about 4 ms after oscillation is stabilized, the condition existing just before power-down is restored in about 100 ms and allows you to control the printer and transfer the data.

b-2) Input to RESET

If the Low level is applied to the RESET pin for 4 ms or more, the power-down mode is reset. However, unless oscillation is stabilized, it is necessary to set the RESET pin to the Low level. After oscillation is stabilized, set the RESET pin to the High level.

This initializes the inside of the unit and starts it in about 100 ms.

D0 through D7 are dot points in each position:

“1” for a point, and “0” for a space.

When n1, n2, n3, are specified beyond their ranges, or when n2=n3=0 is specified, the text mode results with the bit image mode cancelled.

Since this printer prints by 4-dot line, insufficient data is printed as a space after reading in the 4-dot line worth of data or when the n1, n2, n3, specified data is completed.

IN the MD-910 specifications, when n1,=23 is specified, the 4 dots from the most significant dot (MSC DOT) are invalidated. This is because there are 180 dots fro one-line printing positions.

Although the text mode has been restored after bit image printing, the line space=0 has been assumed.

Therefore, it is necessary to perform line feed before printing in the text mode.

Note)

For bit image printing, inverted printing is not performed even if R-type is specified.

c. International character setting; ESC + R + n

The ESC + R + n command specifies the following character table of each country.

n	Country	n	Country
0	U.S.A	5	Sweden
1	France	6	Italy
2	Germany	7	Spain
3	Britain	8	Japan
4	Denmark		

“n” other 0 to 8 is invalid (not changed).

n=8 (Japan) is set at power-on or after a reset.

d. External character registration; ESC + & + A1 + A2

Up to 8-character pattern can be registered by inputting the pattern data following the ESC + & + A1 + A2 command.

Registerable character addresses are the code table 20H through OFFH, that is 8 characters. The character address at the start of registration is "A1", and that at the end of registration is "A2".

When registering one character, it should be A1=A2.
 When registering multiple characters, it should be A1<A2 and A2-A1 ≤ 7.

When external character registration is done in the same character address duplicately, the pattern registered later becomes effective.

If more than 8 characters are registered, all the character patterns registered so far are cleared. The pattern data should be as follows.

The MD-910 specifications require 6 bytes per character.

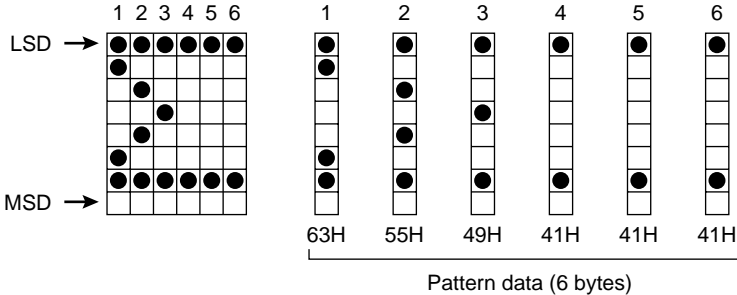

The MD-911 specifications require 7 bytes per character.

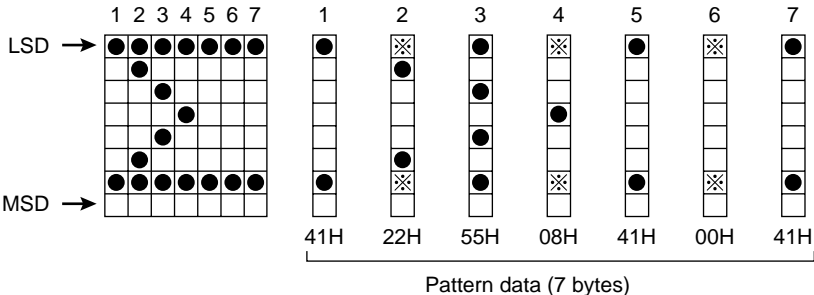

The pattern for the MD-911 specifications does not allow the dots to be consecutively arranged in the printing direction (line direction).
 Printing is not allowed at the point "*" to the right of the point "." shown above. Even if you specify the pattern at the point "*", the print "*" of registration is canceled.

e. Continuous paper feed; ESC + B + n

The ESC + B + n command provides continuous paper feed by “n” lines.

The range of “n” is even-number dot lines within $4 \leq n \leq 255$.

When “n” is an odd number, it is assumed to be an even number of “n-1”.

When the number within the range of “ $0 \leq n \leq 3$ ” is specified for “n”, this command is canceled.

When there is data in the buffer, this command will be carried out n-dot line feed after printing is completed.

If the range of “n” is within $4 \leq n \leq 9$, there is no line space.

4.5 ESC control

The following setting functions can be performed by the ASCII code subsequent to the ESC (1BH) code. If you input other ASCII code than those defined below after the ESC code, that ASCII code and the ESC code are invalidated. In the following commands;

“n” is an 8-bit binary number.

“+” is a separator for convenience sake.

a. Line space setting command: ESC + A + n

The command ESC + A + n allows you to set the interline space of “n” dots. “n” should be $0 \leq n \leq 255$. If an odd number is specified for “n”, the line space will be “n-1” dots. Initial setting for the line space is 2 dots.

b. Bit image printing: ESC + K + n1 + n2 + n3

The command ESC + K + n1 + n2 + n3 changes over the mode from the text mode to the bit image mode. The transfer amount of the bit image data entered subsequent to this command is specified with n1, n2, n3.

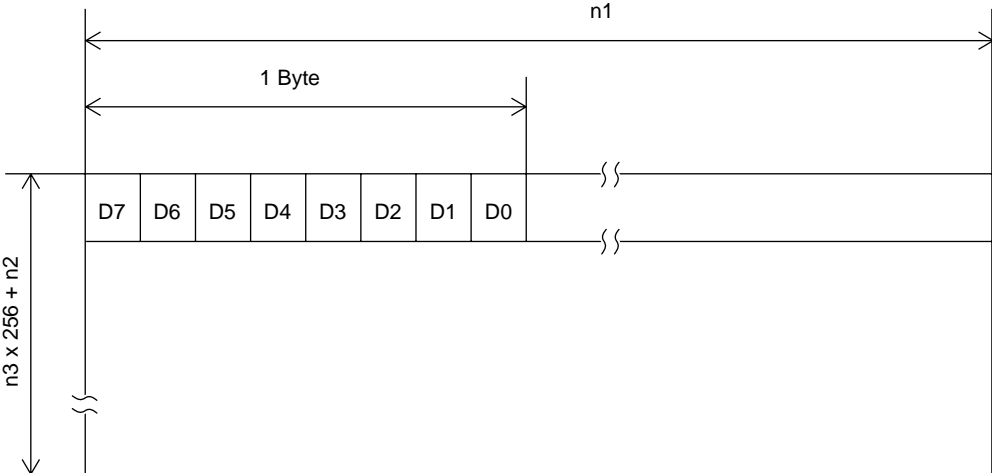

Ranges of n1, n2, n3

	n 1	n 2	n 3
MD - 910	1 ~ 18	0 ~ 255	0 ~ 1
MD - 911	1 ~ 23	0 ~ 255	0 ~ 1

5 CHARACTER CODE TABLE

5.1 INTERNATIONAL CHARACTER CODES

上位 Bit	0	1	2	3	4	5	6	7	8	9	A	B	C	D	E	F
0	0000	0001	0010	0011	0100	0101	0110	0111	1000	1001	1010	1011	1100	1101	1110	1111
1	NUL	SP	!	"	#	\$	%	&	'	()	*	+	,	-	.
2	0	1	2	3	4	5	6	7	8	9	:	;	<	=	>	?
3	0	1	2	3	4	5	6	7	8	9	:	;	<	=	>	?
4	0	1	2	3	4	5	6	7	8	9	:	;	<	=	>	?
5	0	1	2	3	4	5	6	7	8	9	:	;	<	=	>	?
6	0	1	2	3	4	5	6	7	8	9	:	;	<	=	>	?
7	0	1	2	3	4	5	6	7	8	9	:	;	<	=	>	?
8	0	1	2	3	4	5	6	7	8	9	:	;	<	=	>	?
9	0	1	2	3	4	5	6	7	8	9	:	;	<	=	>	?
A	0	1	2	3	4	5	6	7	8	9	:	;	<	=	>	?
B	0	1	2	3	4	5	6	7	8	9	:	;	<	=	>	?
C	0	1	2	3	4	5	6	7	8	9	:	;	<	=	>	?
D	0	1	2	3	4	5	6	7	8	9	:	;	<	=	>	?
E	0	1	2	3	4	5	6	7	8	9	:	;	<	=	>	?
F	0	1	2	3	4	5	6	7	8	9	:	;	<	=	>	?

		U S A	France	Germany	U K	Denmark	Sweden	Italy	Spain
* 1	23H	#	#	#	£	#	#	#	Pt
* 2	24H	\$	\$	\$	\$	\$	¤	\$	\$
* 3	40H	@	à	§	@	@	É	@	@
* 4	5BH	[°	Ä	[Æ	Ä	°	i
* 5	5CH	\	Ç	Ö	\	Ø	Ö	\	Ñ
* 6	5DH]	§	Ü]	À	À	é	í
* 7	5EH	^	^	^	^	^	Û	^	^
* 8	60H	é	ù	.
* 9	7BH	(è	ä	(æ	ä	à	¨
* 10	7CH		ù	ö		ø	ö	ò	ñ
* 11	7DH)	è	ü)	á	á	è)
* 12	7EH	~	¨	β	~	~	ü	ì	~

