

**LINE THERMAL PRINTER/  
PRESENTER UNIT  
MODEL PPU-231  
User's Manual**

# WEEE MARK

**En** If you want to dispose this product, do not mix with general household waste. There is a separate collection systems for used electronics products in accordance with legislation under the WEEE Directive (Directive 2002/96/EC) and is effective only within European Union.

**Ge** Wenn Sie dieses Produkt entsorgen wollen, dann tun Sie dies bitte nicht zusammen mit dem Haushaltsmüll. Es gibt im Rahmen der WEEE-Direktive innerhalb der Europäischen Union (Direktive 2002/96/EC) gesetzliche Bestimmungen für separate Sammelsysteme für gebrauchte elektronische Geräte und Produkte.

**Fr** Si vous souhaitez vous débarrasser de cet appareil, ne le mettez pas à la poubelle avec vos ordures ménagères. Il existe un système de récupération distinct pour les vieux appareils électroniques conformément à la législation WEEE sur le recyclage des déchets des équipements électriques et électroniques (Directive 2002/96/EC) qui est uniquement valable dans les pays de l'Union européenne.

Les appareils et les machines électriques et électroniques contiennent souvent des matières dangereuses pour l'homme et l'environnement si vous les utilisez et vous vous en débarrassez de façon inappropriée.

**Sp** Si desea deshacerse de este producto, no lo mezcle con residuos domésticos de carácter general. Existe un sistema de recogida selectiva de aparatos electrónicos usados, según establece la legislación prevista por la Directiva 2002/96/CE sobre residuos de aparatos eléctricos y electrónicos (RAEE), vigente únicamente en la Unión Europea.

**It** Se desiderate gettare via questo prodotto, non mescolatelo ai rifiuti generici di casa. Esiste un sistema di raccolta separato per i prodotti elettronici usati in conformità alla legislazione RAEE (Direttiva 2002/96/CE), valida solo all'interno dell'Unione Europea.

**Du** Deponeer dit product niet bij het gewone huishoudelijk afval wanneer u het wilt verwijderen. Er bestaat ingevolge de WEEE-richtlijn (Richtlijn 2002/96/EG) een speciaal wettelijk voorgeschreven verzamelsysteem voor gebruikte elektronische producten, welk alleen geldt binnen de Europese Unie.

**Da** Hvis du vil skille dig af med dette produkt, må du ikke smide det ud sammen med dit almindelige husholdningsaffald. Der findes et separat indsamlingssystem for udtjente elektroniske produkter i overensstemmelse med lovgivningen under WEEE-direktivet (direktiv 2002/96/EC), som kun er gældende i den Europæiske Union.

**Por** Se quiser deitar fora este produto, não o misture com o lixo comum. De acordo com a legislação que decorre da Directiva REEE – Resíduos de Equipamentos Eléctricos e Electrónicos (2002/96/CE), existe um sistema de recolha separado para os equipamentos electrónicos fora de uso, em vigor apenas na União Europeia.

**Pol** Jeżeli zamierzasz pozbyć się tego produktu, nie wyrzucaj go razem ze zwykłymi domowymi odpadkami. Według dyrektywy WEEE (Dyrektywa 2002/96/EC) obowiązującej w Unii Europejskiej dla używanych produktów elektronicznych należy stosować oddzielne sposoby utylizacji.

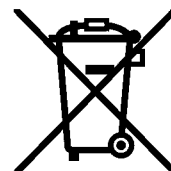

## **Declaration of Conformity**

This printer conforms to the following Standards:

Low Voltage Directive 73/23/EEC, 93/68/EEC and the EMC Directive 89/336/EEC, 92/31/EEC, 93/68/EEC.

LVD : EN60950

EMC : EN55022      Class A  
EN61000-3-2  
EN61000-3-3  
EN55024

This declaration is applied only for 230V model.

**WARNING :** This is a Class A products. In a domestic environment this product may cause radio interference in which case the user may be required to take adequate measures.

CITIZEN is a registered trade mark of CITIZEN WATCH CO., LTD., Japan  
CITIZEN es una marca registrada de CITIZEN WATCH CO., LTD., Japón

## IMPORTANT SAFETY INSTRUCTIONS

- Read all of these instructions and save them for future reference.
- Follow all warnings and instructions marked on the product.
- Unplug this product from the wall outlet before cleaning. Do not use liquid or aerosol cleaners. Use a damp cloth for cleaning.
- Do not use this product near water.
- Do not place this product on an unstable cart, stand or table. The product may fall, causing serious damage to the product.
- Slots and openings on the back or bottom of the case are provided for ventilation. To ensure reliable operation of the product and to protect it from overheating, do not block or cover these openings. The openings should never be blocked by placing the product on a bed, sofa, rug or other similar surface. This product should never be placed near or over a radiator or heater. This product should not be placed in an built-in installation unless proper ventilation is provided.
- This product should be operated from the type of power source indicated on the marking label. If you re not sure of the type of power available, consult your dealer or local power company.
- Do not allow anything to rest on the power cord. Do not place this product where the cord will be walked on.
- If an extension cord is used with this product, make sure that the total of the ampere ratings of the products plugged into the extension cord does not exceed the extension cord ampere rating. Also, make sure that the total of all products plugged into the wall outlet does not exceed 15 amperes.
- •Never push objects of any kind into this product through cabinet slots as they may touch dangerous voltage points or short out parts that could result in a risk of fire or electric shock. Never spill liquid of any kind on the product.
- Except as explained elsewhere in this manual, do not attempt to service this product by yourself. Opening and removing the covers that are marked "Do Not Remove" may expose you to dangerous voltage points or other risks. Refer all servicing on those compartments to service personnel.
- •Unplug this product from the wall outlet and refer servicing to qualified service personnel under the following conditions:
  - A. When the power cord or plug is damaged or frayed.
  - B. If liquid has been spilled into the product.
  - C. If the product has been exposed to rain or water.
  - D. If the product does not operate normally when the operating instructions are followed. Adjust only those controls that are covered be the operating instructions since improper adjustment of other controls may result in damage and will often require extensive work by a qualified technician to restore the product to normal operation.
  - E. If the product has been dropped or the cabinet has been damaged.
  - F. If the product exhibits a distinct change in performance, indicating a need for service.
- Please keep the poly bag which this equipment is packed in away from children or throw it away to prevent children from putting it on. Putting it on may cause suffocation.

## WICHTIGE SICHERHEITSANWEISUNGEN

- Lesen Sie die nachfolgenden Anweisungen sorgfältig durch und bewahren Sie sie auf.
- Befolgen Sie alle auf der Einheit vermerkten Hinweise und Anweisungen. Vor dem Reinigen grundsätzlich Stecker aus der Steckdose ziehen. Keine Flüssigkeiten oder Aerosolreiniger benutzen. Nur mit einem feuchten Tuch abwischen.
- Die Einheit darf nicht in der Nähe von Wasser aufgestellt werden.
- Einheit nicht auf einem unstabilen Wagen, Stand oder Tisch aufstellen. Der Einheit könnte herunterfallen und dabei beschädigt werden.
- Schlitze und Öffnungen im Gehäuse, in der Rückwand und im Boden dienen der Belüftung. Sie dürfen keinesfalls zugedeckt oder blockiert werden, da sich die Einheit sonst überhitzt. Einheit nicht auf ein Bett, Sofa, Teppich oder dergleichen stellen. Einheit nicht in der Nähe eines Heizkörpers aufstellen. Einheit darf nicht eingebaut werden, falls nicht für ausreichende Belüftung gesorgt ist.
- Einheit nur mit der auf dem Typschild angegebenen Spannung betreiben. Wenn Sie sich nicht sicher sind, fragen Sie ihren Händler oder ihr zuständiges Elektrizitätswerk.
- Nichts auf das Stromanschlußkabel stellen. Kabel muß so verlegt werden, daß man nicht darauftreten kann.
- Ein etwaiges Verlängerungskabel muß der Stromstärke aller daran angeschlossenen Geräte entsprechen.
- Keine Gegenstände in die Gehäuseschlitze schieben.
- Einheit darf nur da gewartet werden, wo im Handbuch angegeben, Öffnen und. Abnehmen von Abdeckungen, die mit "Do not remove" gekennzeichnet sind, könnte gefährliche spannungsführende Stellen oder sonstige Gefahrenpunkte freilegen. Die Wartung solcher Stellen darf grundsätzlich nur von besonders ausgebildetem Fachpersonal vorgenommen werden.
  - A. Wenn das Stromanschlußkabel oder der Stecker beschädigt oder durch-gescheuert ist.
  - B. Wenn Flüssigkeit auf der Einheit verschüttet wurde.
  - C. Wenn die Einheit im Regen gestanden hat oder Wasser darauf verschüttet wurde.
  - D. Wenn die Einheit trotz genauer Befolgung der Betriebsvorschriften nicht richtig arbeitet. Nur die in der Bedienungsanleitung angegebenen Einstellungen vornehmen. Ein Verstellen anderer Bedienungselemente könnte die Einheit beschädigen und macht umständliche Arbeiten eines qualifizierten Technikers erforderlich, um die Einheit wieder auf den normalen Betrieb einzustellen.
  - E. Wenn die Einheit heruntergefallen ist oder das Gehäuse beschädigt wurde.
  - F. Wenn die Einheit in seiner Leistung nachläßt.
- Bitte halten Sie den Kunststoffbeutel, in den die Ware verpackt ist, von Kindern entfernt, oder werfen Sie ihn weg, damit er nicht in die Hände von Kindern gerät. Das Überstülpen des Beutels kann zum Ersticken führen.

**Lärmemission kleiner 70dBA**

**<CAUTIONS>**

1. Prior to using the equipment, be sure to read this User's Manual thoroughly. Please keep it handy for reference whenever it may be needed.
2. The information contained herein may be changed without prior notice.
3. Reproduction of part or all of this User's Manual without permission is strictly prohibited.
4. Never service, disassemble, or repair parts that are not mentioned in this User's Manual.
5. Note that we will not be responsible for damages attributable to a user's incorrect operation/ handling or an improper operating environment.
6. Operate the equipment only as described in this User's Manual; otherwise accidents or problems may result.
7. Data are basically temporary; they cannot be stored or saved permanently or for a long time. Please note that we will not be responsible for damages or losses of profit resulting from losses of the data attributable to accidents, repairs, tests, and so on.
8. If you have any questions or notice any clerical errors or omissions regarding the information in this manual, please contact our office.
9. Please note that, notwithstanding Item 8 above, we will not be responsible for any effects resulting from operation of the equipment.

## SAFETY PRECAUTIONS ----- BE SURE TO OBSERVE

In order to prevent hazards to an operator or other persons and damage to property, be sure to observe the following precautions.

- The following describes the degrees of hazard and damages that can occur if the given instructions are neglected or the equipment is incorrectly operated.

**WARNING**

Negligence of this precaution may result in death or serious injury.

**CAUTION**

Negligence of this precaution may result in injury or damage to property.



This is an illustration mark used to alert your attention.



This is an illustration mark used to indicate such information as an instruction or the like.

 **WARNING**

- Never handle the equipment in the following manners, as it may break, become out of order, or overheat causing smoke and resulting in fire or electric shock.  
If the equipment is used in an abnormal condition, such as when broken, then problems, smoke emission, abnormal odor/noise, and fire can result. If an abnormal condition exists, be sure to disconnect the power plug from a plug socket, and contact our dealer. Never repair the equipment on your own - it is very dangerous.
- Do not allow the equipment to receive a strong impact or shock, such as kicking, stomping, hitting, dropping, and the like.
- Install the equipment in a well-ventilated place. Do not use it in such a manner that its ventilation port will be blocked.
- Do not install the equipment in a place like a laboratory where chemical reactions are expected, or in a place where salt or gases are contained in the air.
- Do not connect/disconnect a power cord or a data cable, while holding the cable. Do not pull, install, use, or carry the equipment in such a manner that force will be applied to the cables.
- Do not drop or insert any foreign substances, such as clips or pins, into the equipment.
- Do not spill any liquid or spray any chemical-containing liquid over the equipment. If any liquid is spilled on it, turn off the power, disconnect the power cable and power cord from the plug socket, and so on, and contact our dealer.
- Never disassemble or remodel the equipment. Negligence of this may cause fire or electric shock.
- Use the equipment only with the specified commercial power supply and AC adapter. Negligence of this may result in fire, electric shock, or problems.
- If you drop or break the AC adapter, or if water or the like gets inside it, unplug it immediately from the socket and contact your dealer.
- Do not damage, break, process, bend/pull by force, twist, or head an AC adapter cord. Also, do not put a heavy substance on it or heat it. The AC adapter cord could be broken, resulting in fire, electric shock, or trouble. If the AC adapter cord is damaged, contact our dealer.
- Do not connect/disconnect the AC adapter with wet hands.
- Do not overload a single electrical outlet, using a table tap or a current tap socket.
- An equipment packing bag must be discarded or kept away from children. A child can suffocate if the bag is placed over the head.



## PRECAUTIONS FOR INSTALLATION

- Do not use or store the equipment in a place exposed to fire, moisture, or direct sunshine, or in a place near a heater or thermal device where the prescribed operating temperature and humidity are not met, or in a place exposed to much oil, iron powder, or dust. The equipment may become out of order, emit smoke, or catch fire.
- Do not install or use the equipment in a place like a laboratory where chemical reactions are expected, or in a place where salt or gases are contained in the air. There is a danger of fire or electric shock.
- Install the unit on a flat, stable desk or table that is free from vibration, in a well-ventilated place.
- Do not install the unit at a location where its operation could be hindered.
- Do not place anything on the unit or leave small objects, like a clip or pin, around it. A foreign object could cause trouble if it gets inside.
- Do not use any sharp-pointed object, such as a pen, for example, to touch the operation panel of the unit. It could cause trouble.
- Do not use the equipment near a radio or TV receiver. Do not share the power from a plug socket a radio or TV receiver is connected to. It may cause a reception problem.
- Use the equipment only at the specified power supply, voltage and frequency. Otherwise, it may emit smoke and catch fire or cause other problems.
- Connect only the specified power source. Use of an unspecified power source could cause trouble or smoke/fire.
- Confirm that a plug socket used for connection has sufficient capacity.
- Avoid connecting a power cable to a plug socket shared by other devices or extending the wiring too far. It may result in the cable catching fire or a power outage. Also, do not step on or apply an excessive force (Pull, load) to the cable, and do not use the unit with such a force applied to it.
- Never connect a grounding cable (Frame ground) to a gas pipe. There is a danger of explosion. When connecting or disconnecting the grounding cable, be sure to disconnect the power cable and the power plug from the plug socket.
- When connecting/disconnecting the cables, be sure to turn off the power first, including the connected side, and then connect/disconnect them, holding a plug and a connector. Pulling the cable itself could cause it to snap or become damaged.
- Connect a power cable or a connector cable securely. If a reverse-polarity connection is made, internal elements may be broken or a mating device may be adversely affected.
- Use a shielding wire or twisted pair wire for a signal line, in order to minimize noise effect. Do not route the cable too long or connect it to a noisy device. Connection to a noisy device could cause erroneous printing due to corrupt data, and so on.
- Use the equipment in an environment where there is a plug socket near the main body and you can easily disconnect the power plug from it, to shut off the power.
- When the equipment will not be used for a long period of time, unplug it and remove the paper roll from it.
- When transporting the equipment, remove the paper roll from the paper holder.



## PRECAUTIONS FOR HANDLING

Do not handle the equipment in the following manners, because problems may result.

- Do not use any other power source besides the accessory AC adapter. Also, do not use the AC adapter for other purposes.
- Do not print without paper.
- Do not drop or put any foreign object, such as a clip, pin, or the like, inside the unit.
- Do not spill any liquid or spray any chemical-containing liquid over the equipment.
- Never use a pointed object, such as a pen, to operate the operation panel.
- Do not use Scotch tape to fasten paper together for continuous use. It could damage the printing head.
- Never pull the set paper forcibly. When opening/closing the unit cover, take care that the paper will not be caught. It could cause the paper to jam.
- Be sure to use the specified paper. Use of other paper could deteriorate the print quality or cause a problem with the printing head.

### To Prevent Injury and Spreading of Damage

- Never touch the printing head, motor, or paper cutting blade. Your finger may be cut.
- During power-on or immediately after printing, do not touch electrical parts or moving parts, such as the mechanism, motor, internal gear, etc. They may be very hot and can burn your hand/finger.
- Be careful to avoid bodily injure or damaging other objects with an edge of sheet metal.
- Should any error occur while operating the equipment, stop it immediately and disconnect the power plug from the plug socket.
- Only a qualified serviceman is allowed to disassemble or repair the unit.
- Should a problem occur, leave solving it to our serviceman. Do not disassemble the equipment on your own.
- When opening/closing the unit cover, and so on, be careful not to catch your hand or finger on the equipment.
- After using the equipment, turn off the power switch and unplug the AC adapter from a plug socket.

## DAILY MAINTENANCE

- At the time of maintenance, be sure to turn off the power switch of the unit and unplug it from the socket.
- Use a dry soft cloth to wipe off stains and dust from the surfaces of the main body case. For severe soiling, dip the cloth in water and wring it, for wiping off the soil. Never use organic solvents, such as alcohol, thinner, trichlene, benzene, ketone, or chemical dusters.
- If the equipment is contaminated with paper powder, use a soft brush to clean it. Be careful not to damage the printing head.

 **CAUTION:** The printing head and motor are very hot. Be careful not to touch them immediately after printing. Do not touch the heating surface of the head with a bare hand or metal.

## CONTENTS

<b>1. OUTLINE .....</b>	<b>1</b>
1.1 Features .....	1
1.2 Unpacking .....	1
<b>2. BASIC SPECIFICATIONS .....</b>	<b>2</b>
2.1 Model Classifications .....	2
2.1.1 PPU series (Printer/Presenter unit) .....	2
2.1.2 Options .....	3
2.1.3 Miscellaneous .....	4
2.2 Basic Specifications .....	6
2.3 Paper Specifications .....	7
2.3.1 Recommended Paper .....	7
2.3.2 Printing Position .....	7
2.3.3 Printing Head and Paper Cutter Layout .....	8
<b>3. OUTER APPEARANCE AND COMPONENT PARTS.....</b>	<b>9</b>
3.1 PPU (Printer/Presenter Unit) .....	9
3.2 Optional PHU (Paper Holding Unit) .....	11
<b>4. OPERATION.....</b>	<b>12</b>
4.1 Connecting the AC Adapter .....	12
4.1.1 Using the Power Connector .....	12
4.1.2 Connecting a Power Cable to the Control PCB .....	13
4.2 Connecting the Interface Cable .....	14
4.3 Inserting the Paper.....	17
4.4 How to Remove Remaining Paper Roll .....	18
4.5 Eliminating the Paper Jam.....	19
4.5.1 Eliminating a Jam in the Printer Mechanism .....	19
4.5.2 Eliminating a Jam in the Presenter .....	20
4.6 Releasing a Locked Cutter.....	21
4.7 FEED Switch Function.....	21
4.8 Paper End Function .....	21
4.9 Connecting the PHU (Paper Holding Unit) .....	22
4.10 Paper Near End Function (When Using the PHU) .....	22
4.11 Auto-Loading Function .....	23
4.12 Self-Print Function .....	23
4.13 Presenter Control .....	23

---

<b>5. DIP SWITCH SETTING</b> .....	<b>24</b>
5.1 Location of DIP Switch .....	24
5.2 DIP Switch Function .....	25
<b>6. PARALLEL INTERFACE</b> .....	<b>27</b>
6.1 Specifications .....	27
6.2 Connector's Pin Configuration.....	27
6.3 Input and Output Signals .....	28
6.3.1 Input and Output Signals .....	28
6.3.2 Electrical Characteristics .....	29
6.3.3 Timing Chart.....	30
6.3.4 Data Receiving Control .....	30
6.3.5 Buffering.....	30
<b>7. SERIAL INTERFACE</b> .....	<b>31</b>
7.1 Specifications .....	31
7.2 Connector's Pin Configuration.....	31
7.3 Input and Output Signals .....	32
7.3.1 Input and Output Signals .....	32
7.3.2 Data Configuration .....	33
7.3.3 Error Detection .....	33
7.3.4 Data Receiving Control .....	34
7.3.5 Buffering.....	34
7.3.6 Electrical Characteristics .....	34
<b>8. POWER CONNECTOR</b> .....	<b>35</b>
<b>9. MAINTENANCE AND SERVICE</b> .....	<b>36</b>
<b>10. PRINT CONTROL FUNCTIONS</b> .....	<b>37</b>
10.1 Command List .....	37
10.2 Command Details .....	39
10.2.1 Description of Items.....	39
10.2.2 Details .....	40
<b>11. CHARACTER CODES TABLE</b> .....	<b>81</b>
11.1 International (Page 0).....	81
11.2 Japanese (Page 1) .....	82
11.3 International Character Code Table .....	83

<b>APPENDIX 1. BLOCK DIAGRAM .....</b>	<b>84</b>
<b>APPENDIX 2. OUTLINE DRAWING FOR PPU.....</b>	<b>85</b>
<b>APPENDIX 3. OUTLINE DRAWING FOR PHU.....</b>	<b>86</b>

## 1. OUTLINE

Packed with features, this small line thermal printer/presenter has a wide range of uses: a terminal device for various data communication, an instrumentation terminal, an outdoor information terminal or a device that prints various tickets and coupons. Please read this manual thoroughly before you use the printer/presenter to ensure it is implemented correctly.

### 1.1 Features

1. Small, lightweight, and installable in a narrow area
2. High speed and low noise, owing to line thermal print
3. Long-life printing head and high reliability, owing to the simple mechanism
4. Easy paper-loading, owing to the auto-loading function
5. Built-in input buffer
6. Capable of printing a bar code (Special command)
7. You can choose where you attach the power connector, interface connector, etc.
8. Large diameter paper roll support

### 1.2 Unpacking

When unpacking the package, confirm that the following parts are provided:

- Printer/Presenter unit           ----- 1 unit
- User's manual                   ----- 1 copy

### CAUTION

- 1) Install the unit body on a flat and stable device.
- 2) Do not install the unit near a heater or in a place exposed to the direct sunshine.
- 3) Do not use the unit in a high-temperature, high-humidity, or contaminated environment.
- 4) Do not allow dew condensation to form on the unit. If such condensation should form, do not turn on the power until it has completely gone away
- 5) Use only the specified AC adapter. Do not use it for any other purpose.
- 6) If you do not use the unit for a long period, disconnect the power cable from the socket.
- 7) Keep this manual carefully at hand for ready reference. Put the AC power cord close to a heating device.

## 2. BASIC SPECIFICATIONS

### 2.1 Model Classifications

Classification is made according to the following naming system.

#### 2.1.1 PPU series (Printer/Presenter unit)

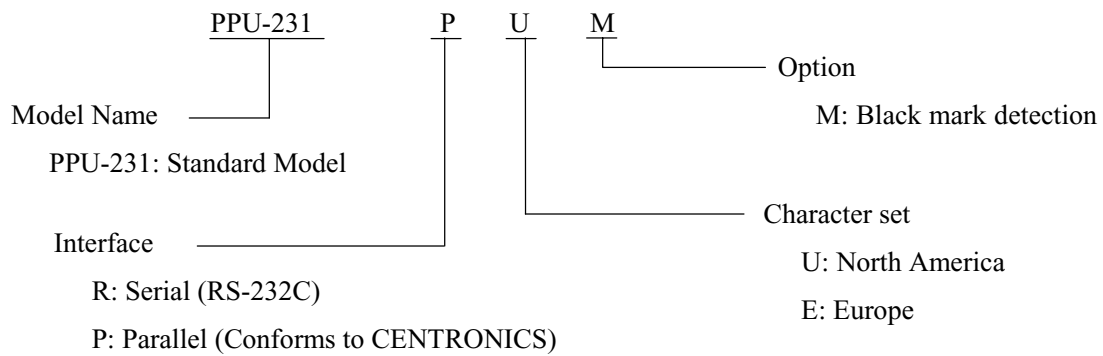

For PPU-231 R U or E (Serial Interface):

The type of cable fixing screws for the serial interface connector depends on the destinations.

U: Inch type screws

E: mm type screws

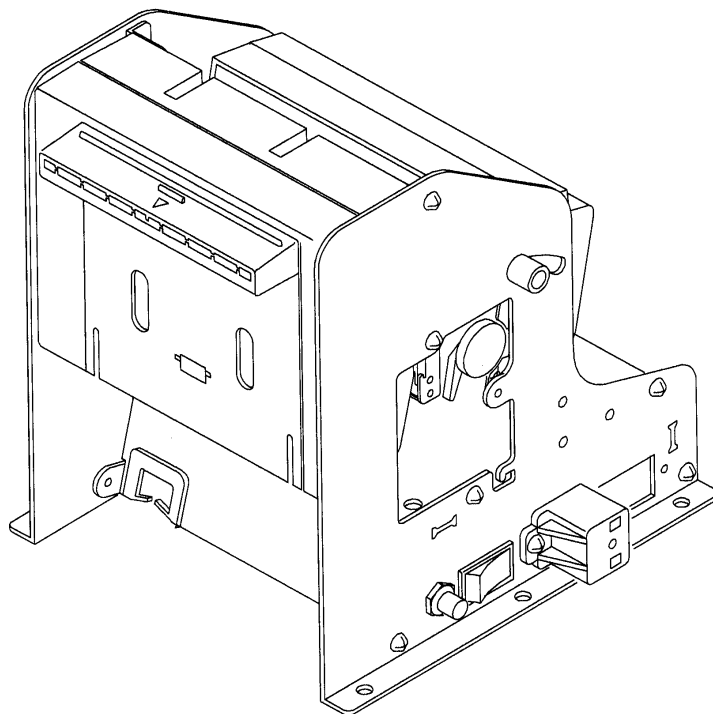

## 2.1.2 Options

### (1) PHU series (Paper holding unit)

Model Name	PHU-13 1	PNE Sensor
	PHU-131: Standard Model	1: 1 piece
		2: 2 pieces

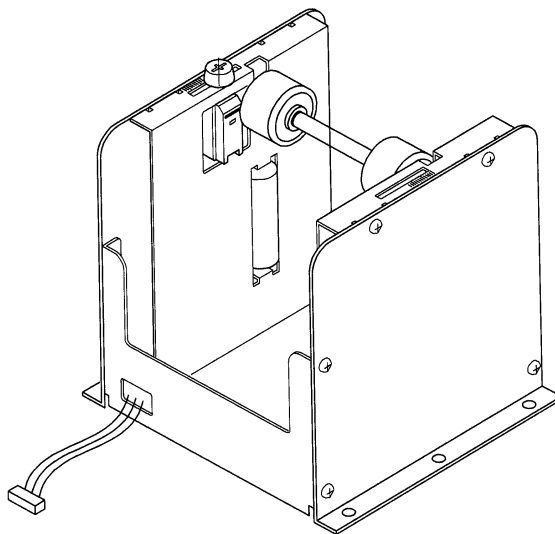

### (2) 31AD series (Power supply unit)

Model Name	31AD-U	Destinations
	U	U: North America (120 V AC)
	E	E: Europe (230 V AC)

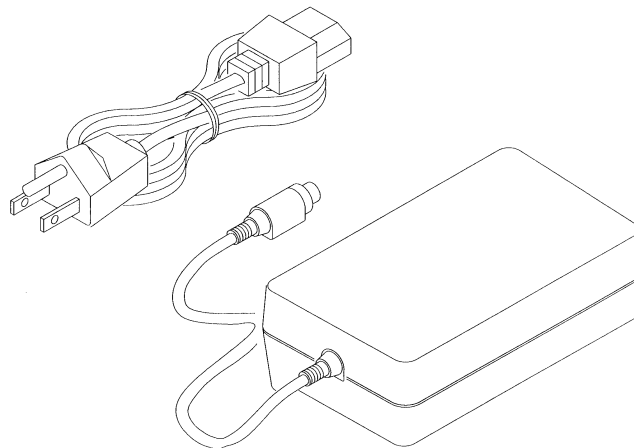

### 2.1.3 Miscellaneous

The following models are sold as single units.

#### (1) PRU series (Presenter unit)

PRU-130

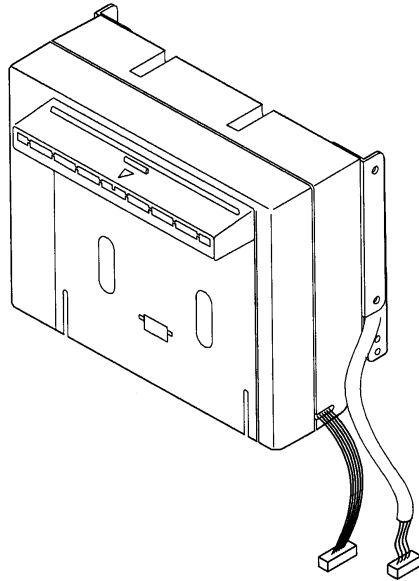

#### (2) PMU series (Printer mechanism unit)

PMU-230

M

Option

M: Black mark detection

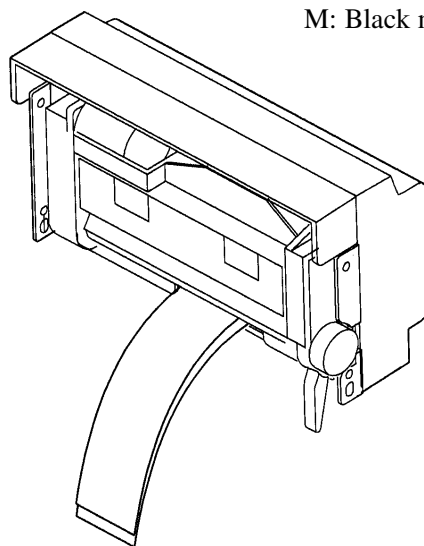

**(3) BD2 series (Control PCB with accessories)**

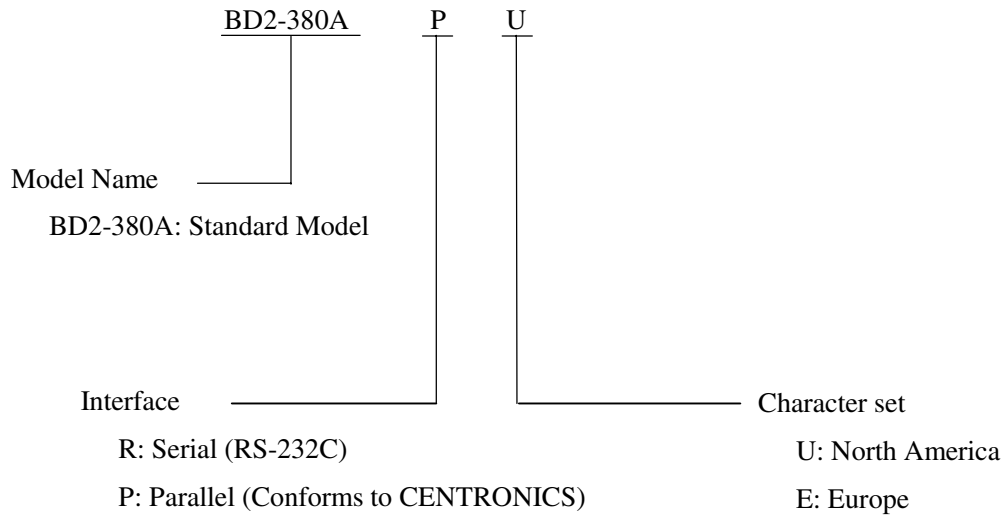

For BD2-380A R U or E (Serial Interface):

The type of cable fixing screws for the serial interface connector depends on the destinations.

U: Inch type screws

E: mm type screws

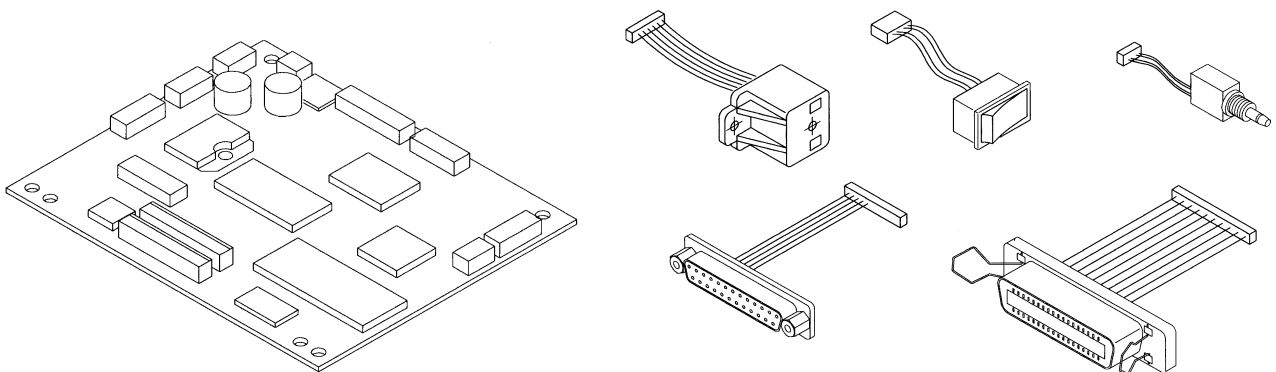

A more detailed specification description is listed in the PHU, PRU, PMU, BD2 user's manual, which is a separate booklet.

## 2.2 Basic Specifications

Item	Description
Printing system	Line thermal dot printing
Printing width	72 mm (576 dots/line)
Dot density	8 dots/mm (Width, Length)
Printing speed	62.5 mm/sec. (At maximum), 500 dots/sec.
Printing columns and character size	48 columns (12 × 24 Font A) 1.25 × 3.00 mm 64 columns (9 × 24 Font B) 0.88 × 3.00 mm
Line interval	Initial value: 4.23 mm (1/6 inch) Can be set with a command (1/203 inch at minimum)
Character types	Alphanumeric, Japanese, international characters
Bar code type	UPC-A, JAN(EAN) 13-/8-column, ITF, CODE 39, CODE 128, CODABAR
Used Paper (See Paper Specifications)	Thermal paper roll Width : 80 mm Outer diameter : φ203 mm (Max.), (When using PHU) Inner diameter : φ25.4 mm (Max.) Thickness : 60~85μm
Presenter	Length of normal issue 64 ~ 305mm (Can be adapted to issue 457mm lengths) 2.5 ~ 12 inches (Can be adapted to issue 18 inch lengths)
Interface	Serial (RS-232C), Parallel (Conforms to CENTRONICS)
Input buffer	4 KB
Command	ESC/POS
Sensors	Paper near end sensor (When using PHU, position adjustable) Paper end sensor (When using PMU) Black mark sensor (Option)
Supply voltage	24 V DC +/- 7%
Power consumption	100 W
Weight	PPU : 1.6 kg (Control PCB included) PHU : 0.9 kg (Paper roll excluded)
Outer dimensions	PPU : 144.7 (W) × 160 (D) × 172 (H) mm PHU : 132.2 (W) × 120 (D) × 125.2 (H) mm *: Protruding parts are not included. For details, see Appendices 2 and 3.
Operating temperature and humidity	5 ~ 40°C, 35 ~ 85 % RH (No dew condensation)
Storage temperature and humidity	-20 ~ 60°C, 10 ~ 90% RH (No dew condensation)
Reliability	Printing head life: Pulse resistance : 50 million pulses or more (Print rate 12.5%) Wear resistance : 30 km or more (With recommended thermal paper at normal temperature and humidity) Auto cutter life: 300,000 cuts (With recommended thermal paper at normal temperature and humidity)

## 2.3 Paper Specifications

### 2.3.1 Recommended Paper

- Type : Thermal paper
- Paper width : 80 + 0/- 1 mm
- Paper thickness : 60 ~ 85 $\mu$ m
- Roll diameter :  $\phi$ 203 mm or less (When using PHU)
- Printing surface : Outside of the roll (Surface)
- Recommended paper : TF50KS-E, E2C (Monochrome) made by NIPPON SEISHI or its equivalent
- Core :  $\phi$ 25.4 mm (Inner diameter)

### CAUTION:

- 1) Use of non-specified paper may cause irregularity of print density. If this is the case, use the DIP switch to reset print density. (See 5. DIP SWITCH SETTING)
- 2) Do not paste the paper to the core.
- 3) If the paper comes in contact with a chemical or oil, it may discolor or lose a record.
- 4) Do not rub the paper surface strongly with a nail or hard metal. It may discolor.
- 5) Discoloring starts at about 70°C. Watch out for effects of heat, humidity, light, and so on.

### 2.3.2 Printing Position

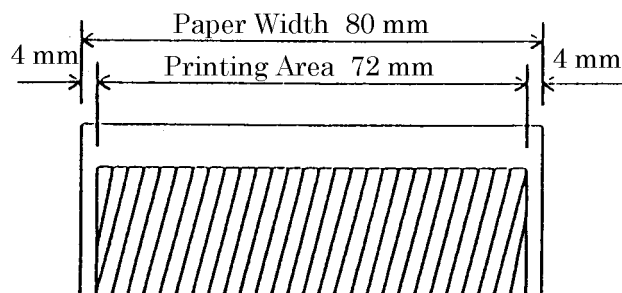

### 2.3.3 Printing Head and Paper Cutter Layout

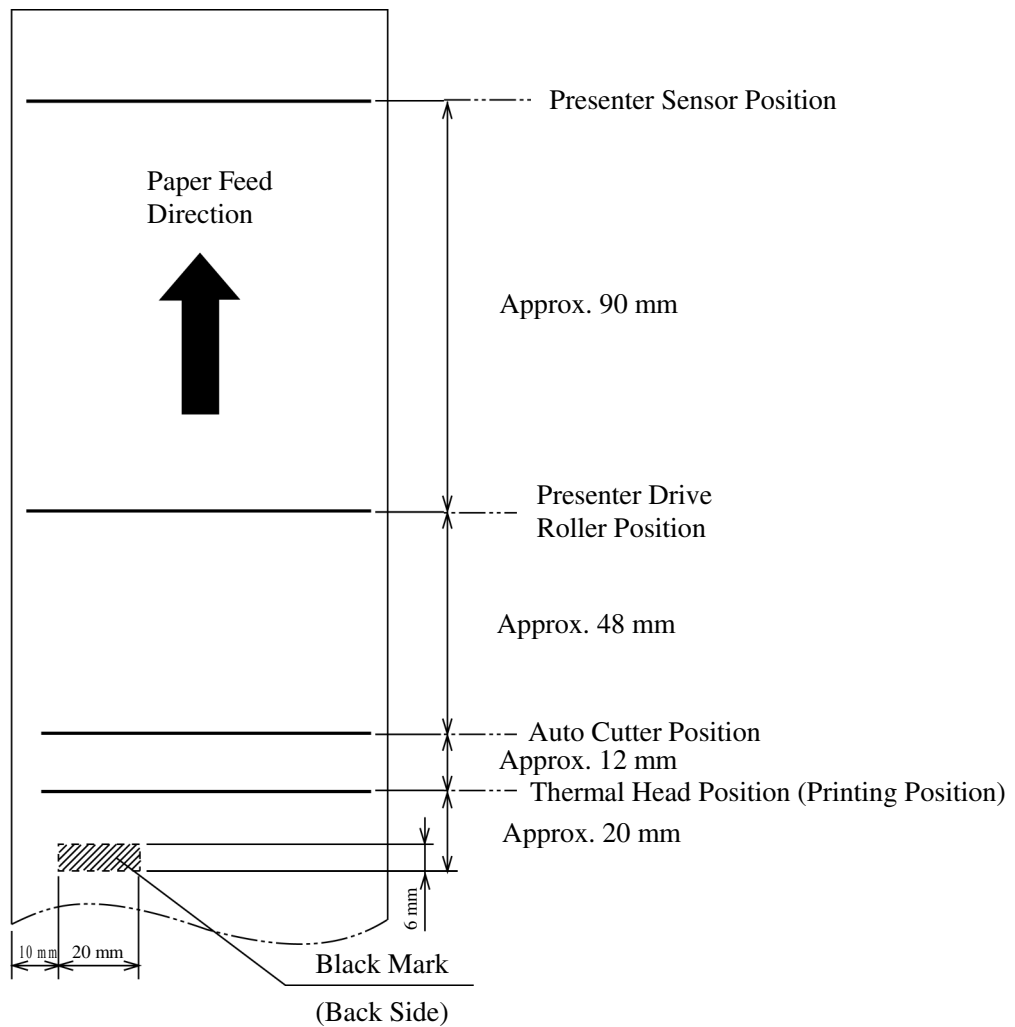

### 3. OUTER APPEARANCE AND COMPONENT PARTS

#### 3.1 PPU (Printer/Presenter Unit)

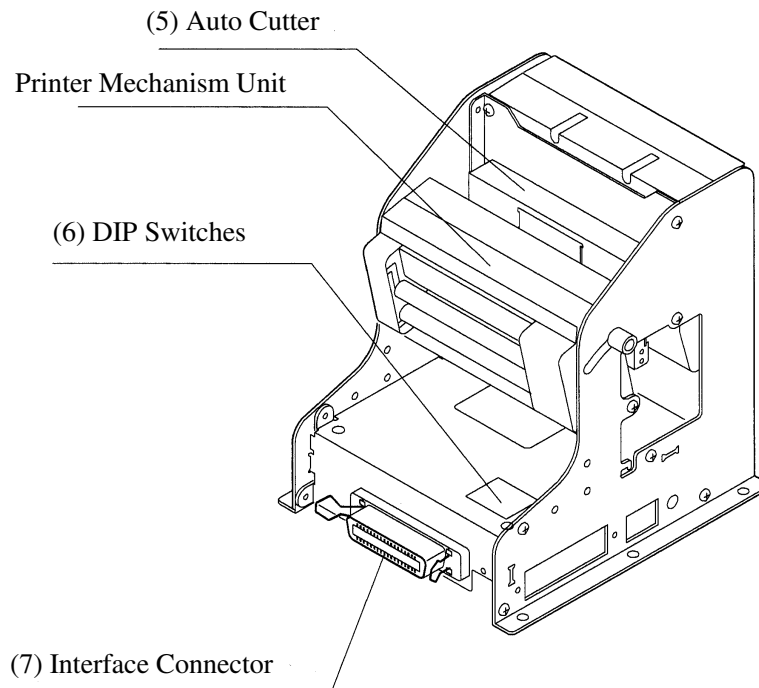
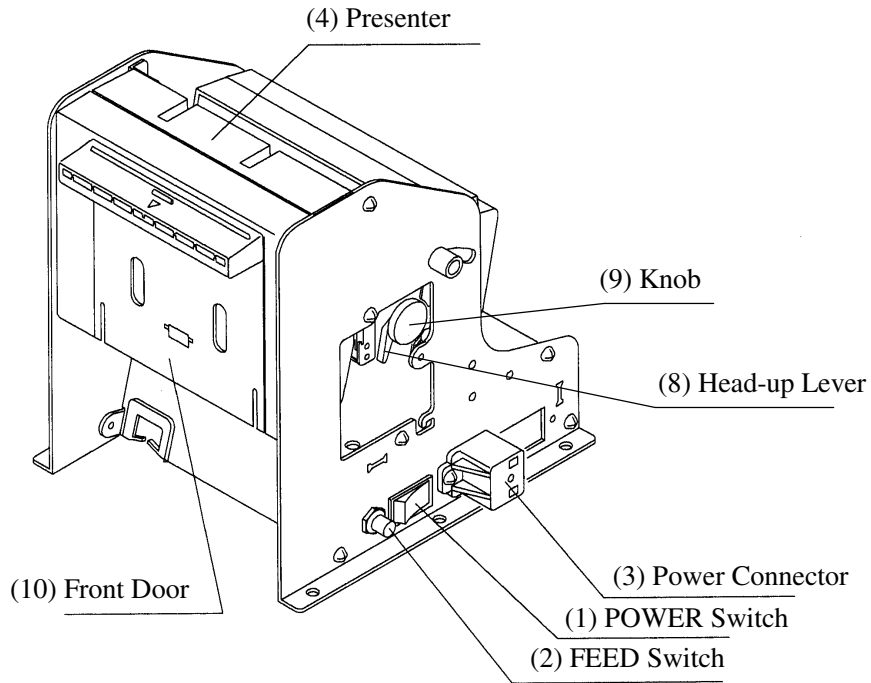

- (1) **POWER switch**  
Turns on/off the power for the printer/presenter unit  
(The POWER switch can be mounted either side of the unit.).
- (2) **FEED switch**  
Feeds the paper to exit the paper.
- (3) **Power connector**  
Connects to the optional AC adapter (31AD).  
(The power connector can be mounted at any one of the 6 locations on the unit. See 4.1.1 "Connecting the AC Adapter".)
- (4) **Presenter**  
Feeds the paper roll.
- (5) **Auto Cutter**  
Automatically cuts the printed paper by a command. Either partial cut or full cut is selectable.
- (6) **DIP switches**  
Initially set the printer/presenter unit at power-on and set the functions.
- (7) **Interface connector**  
Connects to a communication interface cable. There are two types, for serial and parallel interfaces.
- (8) **Head-up lever**  
Used when inserting the paper or exiting the paper.
- (9) **Knob**  
Use this to manually feed the paper.
- (10) **Front door**  
Open this door to remove remaining paper inside the presenter.

### 3.2 Optional PHU (Paper Holding Unit)

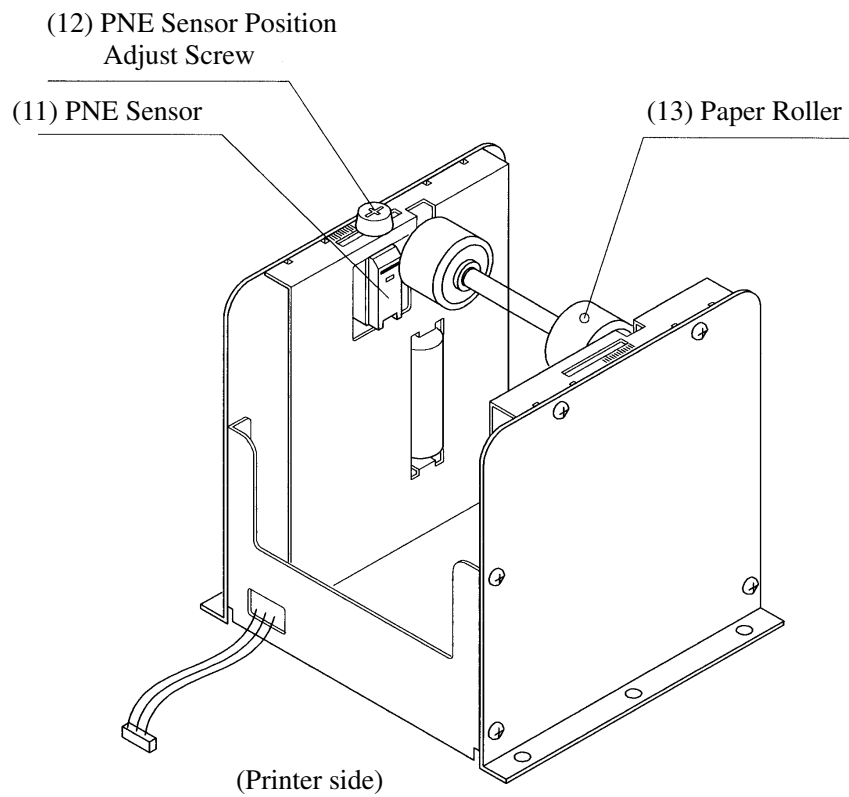

- (11) PNE (Paper Near End) sensor  
Detects that the paper is running out.
- (12) PNE sensor position adjust screw  
Use this screw to adjust the paper remaining amount until paper near end sensor is activated.
- (13) Paper roller  
Holds the paper roll.

## 4. OPERATION

### 4.1 Connecting the AC Adapter

#### 4.1.1 Using the Power Connector

1. Make sure the power switch of the unit is turned off.
2. Connect an optional AC adapter cable connector with the power connector of the unit so that it locks in place.  
(As shown in the figure below, the power connector can be mounted at any one of the 6 locations on the unit.)
3. Connect an optional AC power cord to the AC adapter and plug it into an electrical outlet.

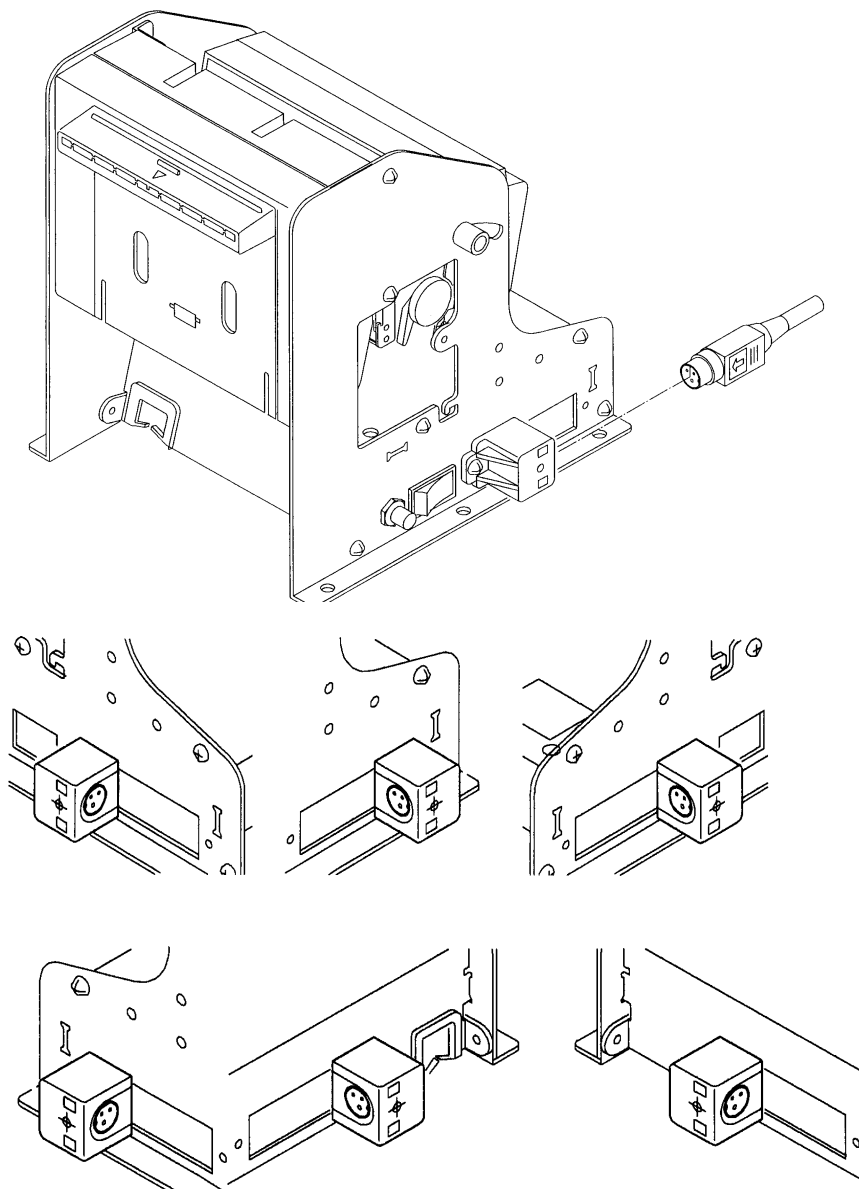

#### 4.1.2 Connecting a Power Cable to the Control PCB

If you wish, you do not need to use an optional AC adapter, instead you can directly connect a power cable (not supplied) to the control PCB.

1. Turn off the power.
2. Plug the power cable into the CN1 power connector of the control PCB. See the table below for detail on the CN1 connector pin configurations.

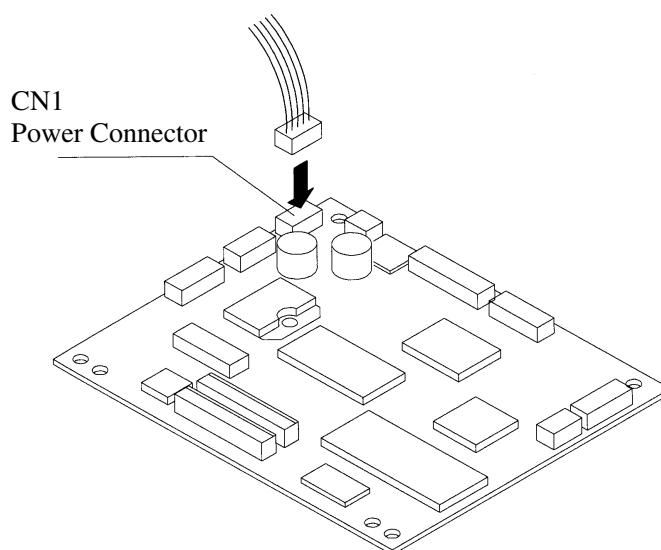

[Connector's pin configuration for power supply (CN1)]

No.	Signal Name	Input/Output	Function
1	+24V DC	Input	Input Voltage
2	+24V DC	Input	Input Voltage
3	P-GND	—	GND
4	P-GND	—	GND
5	P-GND	—	GND

Connector used: 5267-05A-X (Molex)

#### CAUTION:

- 4) Use only the specified AC adapter.
- 5) When disconnecting/reconnecting the cable connector of the AC adapter, be sure to hold the connector.
- 6) Several holes have been prepared on the unit so that the power connector or interface connector can be easily attached. Never use the same hole for both the power connector and interface connector at the same time.
- 4) Separate the AC adapter from other noise-generating devices.
- 5) Pulling the AC power cord may damage it, resulting in a fire, electric shock, or snapping.

- 6) If a thunder/lightning storm is nearby, disconnect the AC adapter from the socket and do not use the printer, because a fire or electric shock may occur.
- 7) Do not put the AC power cord close to a heating device. Its coating can melt and cause a fire or electric shock.
- 8) Install the printer in a well-ventilated place, because the AC adapter generates heat when it is used.
- 9) Use the specified AC power source. Connect to a power source with sufficient capacity. If the capacity is insufficient, a fire may result from heat generation.
- 10) After using the printer or when not using it for a long period of time, be sure to unplug the AC adapter from a plug socket for your safety.

## 4.2 Connecting the Interface Cable

1. Turn off the power. (Mating side included)
2. Check the top and bottom of cable terminals, and connect the cable terminal to the interface connector.
3. Fix the cable terminals.

Serial interface	:	Tighten screws, to fix it.
Parallel interface	:	Turn stoppers, to fix it.
4. Connect the cable to the host computer.

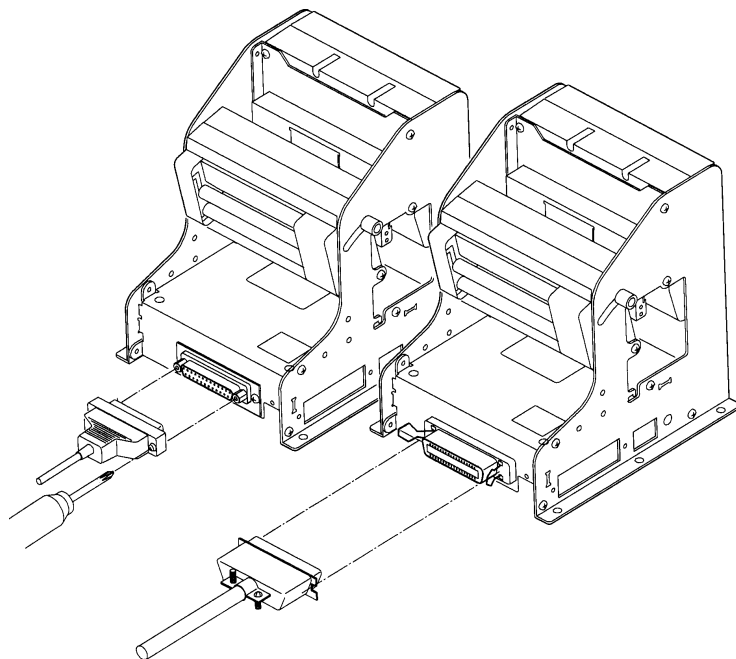

\* This shows how to connect to the rear end of the frame.

You can attach the interface cable to any one of the 4 positions shown below. See the table below for details on the CN10 connector pin configurations.

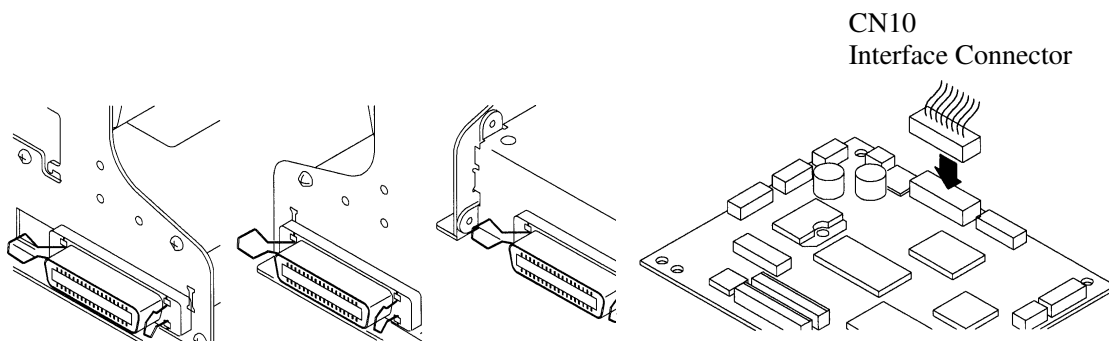

[Connector's pin configurations for parallel interface (CN10)]

No.	Signal Name	Input/Output	Function
1	—	—	—
2	—	—	—
3	—	—	—
4	—	—	—
5	$\overline{\text{STB}}$	Output	$\overline{\text{STB}}$ Signal
6	BUSY	Output	BUSY Signal
7	$\overline{\text{ACK}}$	Output	$\overline{\text{ACK}}$ Signal
8	DATA0	Input	DATA0 Signal
9	DATA1	Input	DATA1 Signal
10	DATA2	Input	DATA2 Signal
11	DATA3	Input	DATA3 Signal
12	DATA4	Input	DATA4 Signal
13	DATA5	Input	DATA5 Signal
14	DATA6	Input	DATA6 Signal
15	DATA7	Input	DATA7 Signal
16	$\overline{\text{PE}}$	Output	$\overline{\text{PE}}$ Signal
17	$\overline{\text{FAULT}}$	Output	$\overline{\text{FAULT}}$ Signal
18	$\overline{\text{RESET}}$	Input	$\overline{\text{RESET}}$ Signal
19	GND	—	GND
20	Vcc	—	+5V DC

Connector used: 53313-2015 (Molex)

[Connector's pin configuration for serial interface (CN10)]

No.	Signal Name	Input/Output	Function
1	DTR	Output	DTR Signal
2	TXD	Output	TXD Signal
3	RXD	Output	RXD Signal
4	DSR	Output	DSR Signal
5	—	—	—
6	—	—	—
7	—	—	—
8	—	—	—
9	—	—	—
10	—	—	—
11	—	—	—
12	—	—	—
13	—	—	—
14	—	—	—
15	—	—	—
16	—	—	—
17	—	—	—
18	—	—	—
19	GND	—	GND
20	Vcc	—	+5V DC

Connector used: 53313-2015 (Molex)

 **CAUTION:**

- 1) Referring to "6. PARALLEL INTERFACE" and "7. SERIAL INTERFACE," check the pin configuration of the interface connector and cable. Wrong wiring could cause trouble or malfunctioning to not only the unit but also the host computer.
- 2) When disconnecting/reconnecting the interface cable, be sure to hold the connector. Pulling the cable itself may snap the internal wires.
- 3) Connect the interface cable securely. Otherwise, communications may not be obtained due to a connection failure.

### 4.3 Inserting the Paper

#### CAUTION:

- 1) Be sure to use the specified paper roll.
- 2) Use of non-specified paper may not guarantee the print quality, printing head life, presenter operation, and so on.
- 3) Do not insert a ragged or dog-eared end of the paper roll, because it could result in a paper jam or insertion error.

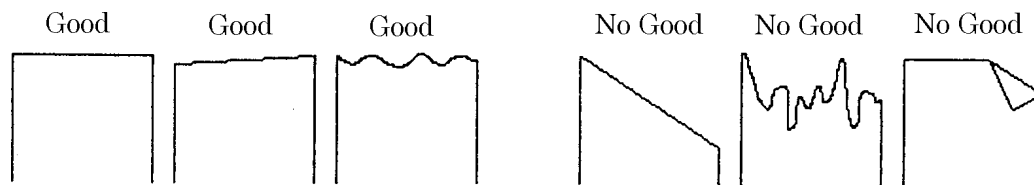

1. Cut the front end of the paper roll almost at a right angle.
2. Insert the paper roller of the paper holding unit into the core of the paper roll as shown in the figure on the next page.
3. Make sure the paper winding direction and put the paper roll onto the PHU.
4. Make sure that the power is turned on.
5. If there is still some paper remaining after a paper-out indication, eliminate the paper roll according to "4.4 How to Remove the Remaining Paper Roll."
6. Raise the head-up lever of the printer/presenter unit. (See the next page.)
7. Insert the front end of the paper roll straight into a paper insertion slot as shown in the figure on the next page, until the paper stops.
8. Put back the head-up lever. The paper is automatically pulled in by the platen roller to feed a constant amount of paper. (When auto-loading is enabled.) Remove the cut paper to enable printing.

#### CAUTION:

- 1) If the paper roll is still slack, rewind the paper to remove the slack.
- 2) If the paper roll is tilted, raise the head-up lever to correct the paper roll position, or pull out the paper roll and set it again.
- 3) Do not hold or press the paper roll while printing, because it could cause a paper jam.
- 4) After the paper is set, the printer is made ready to start printing. Note that if data is remaining in the buffer, the printer will start printing after the paper is set.

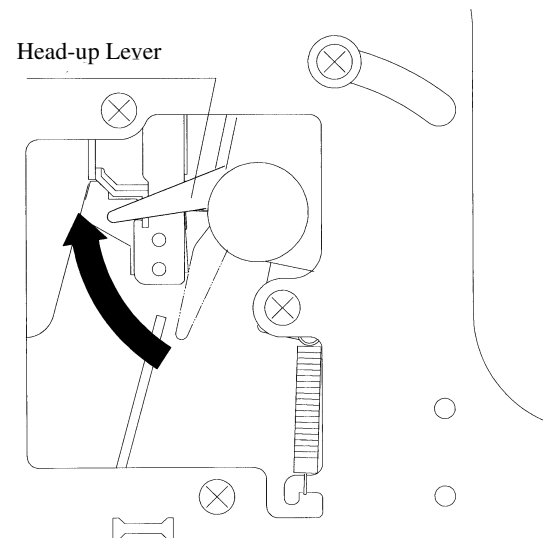
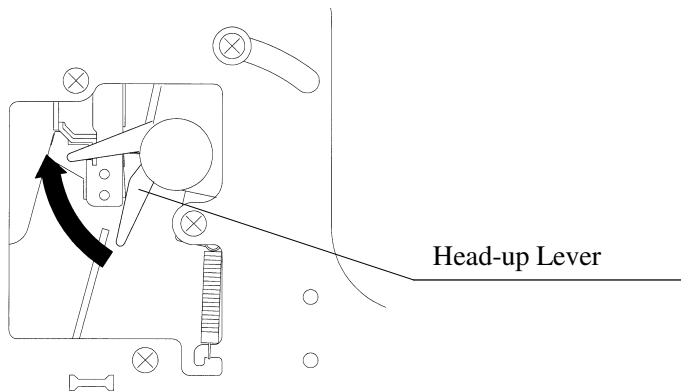
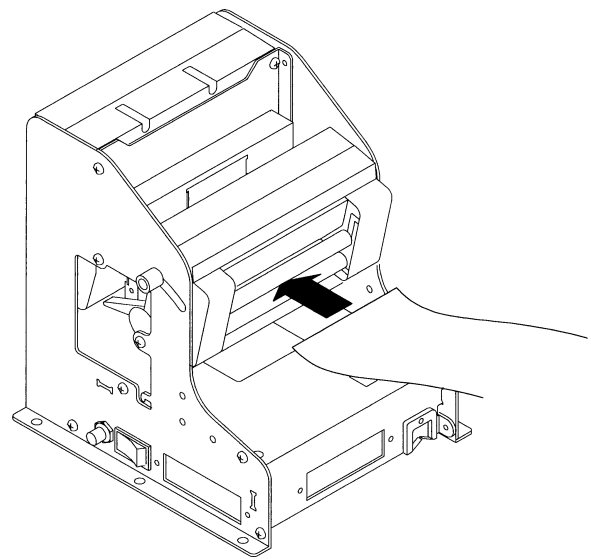
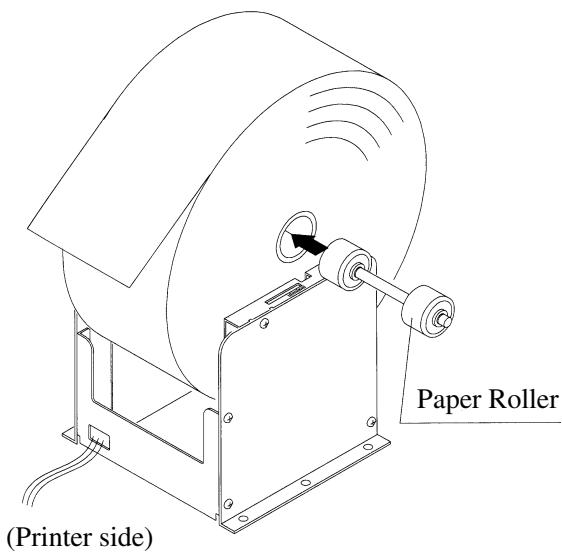

#### 4.4 How to Remove Remaining Paper Roll

1. Raise the head-up lever of the printer/presenter unit.
2. Gently pull out the paper from the printer/presenter unit.  
If the paper roll is still remaining, cut it just before the paper insertion slot before pulling it out.

**⚠ CAUTION:**

- 1) Never take out paper with the head-up lever lowered, because it could damage the printing head.
- 2) The printer mechanism may be very hot just after printing, so be duly careful.

## 4.5 Eliminating the Paper Jam

### 4.5.1 Eliminating a Jam in the Printer Mechanism

1. Turn off the power.
2. Cut the paper roll near the paper insertion slot.
3. Move the knobs on both sides in the direction indicated by the arrows to detach the auto cutter from the printer mechanism.
4. Raise the head-up lever to detach the head from the platen roller.
5. Rotate the knob of the printer mechanism and totally remove the paper roll that is left in the paper passage.
6. Lower the head-up lever to return the printer mechanism to its original position.

#### CAUTION:

- 1) The printer head gets very hot. Do not attempt any maintenance directly after printing.
- 2) When you wish to remove the unused portion of the paper, do not touch the hot surface of the printer head with your bare hands or a piece of metal.

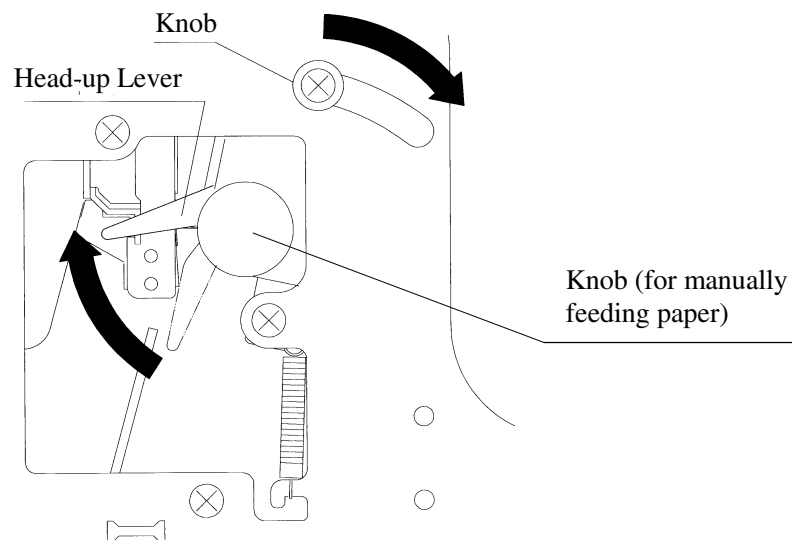

#### 4.5.2 Eliminating a Jam in the Presenter

1. Turn off the power.
2. Open the front door by pulling while pressing on the knob (see the figure).
3. Manually turn the roller until all paper is removed from the paper passage.
4. If a jam occurs between the auto-cutter and the presenter, with tweezers or similar, remove the paper roll with the utmost care.
5. Firmly close the front door.

#### CAUTION:

If the presenter rollers do not spin, do not apply extra force as this could break the mechanism.

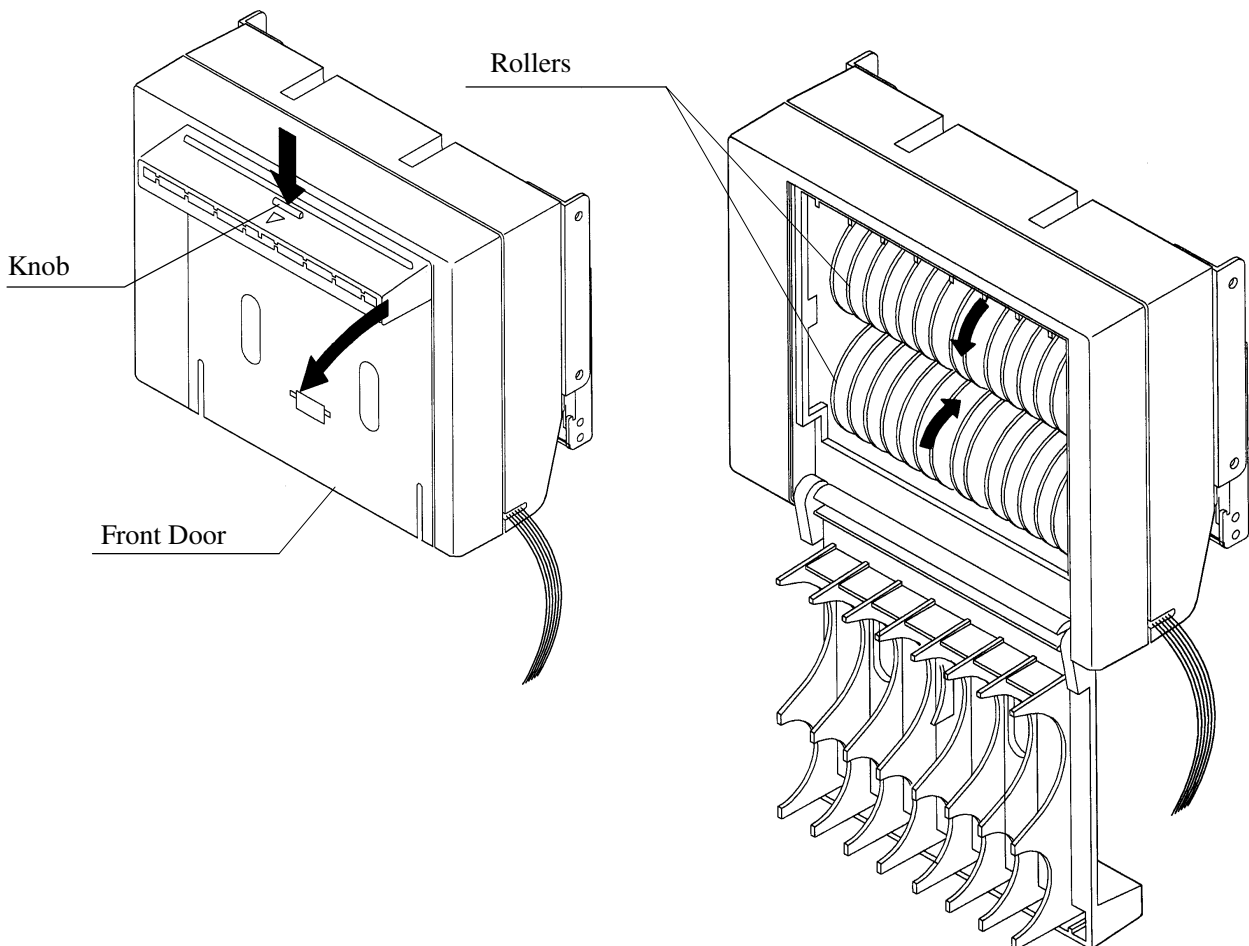

## 4.6 Releasing a Locked Cutter

When the auto-cutter locks up and fails to cut paper, follow these steps to solve the problem.

1. Remove the paper from the paper passage as described in "4.5 Eliminating the Paper Jam".
2. Turn on the power. The auto cutter initialization begins and the cutter returns to its home position.
3. If the cutter does not return to its home position after the power has been turned on, do the following.  
Turn off the power, and return the auto cutter blade to its home position by turning the emergency knob of the auto cutter in the direction indicated by the arrow.
4. With tweezers or similar, totally remove remaining paper from the cutter blade area.

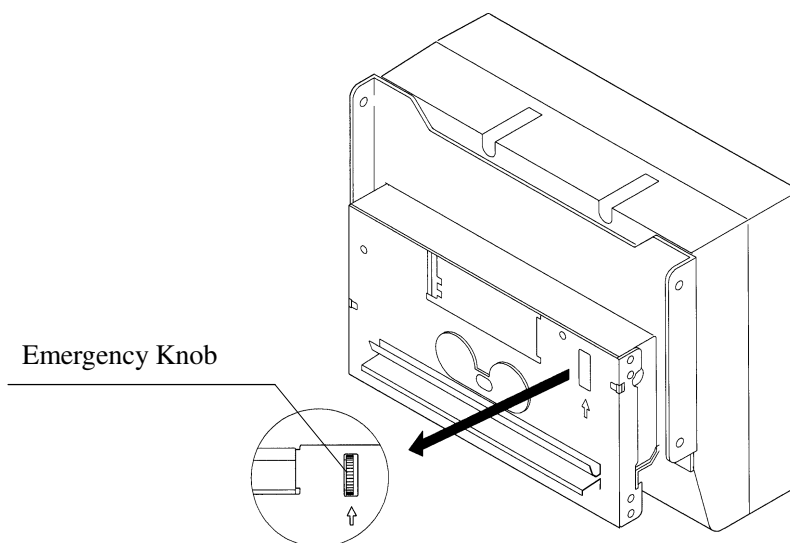

## 4.7 FEED Switch Function

Press the feed switch to feed the paper, cut it, and output the cut portion.

## 4.8 Paper End Function

If the printing paper runs out, the parallel interface will output BUSY, FAULT, and PE to the host, and the serial interface will output DTR to stop printing, respectively. If some data are still remaining in the buffer, printing will be resumed after replacing the paper. Replace the paper according to "4.3 Inserting the Paper." After replacing the paper, cancel BUSY (DTR), FAULT, and PE outputs. For details, see "4.10 Near Paper End Function."

#### 4.9 Connecting the PHU (Paper Holding Unit)

1. Turn off the power.
2. Plug the connector cable of the optional PHU into the CN5 on the control PCB.

When plugging it, pay attention to its insertion direction.

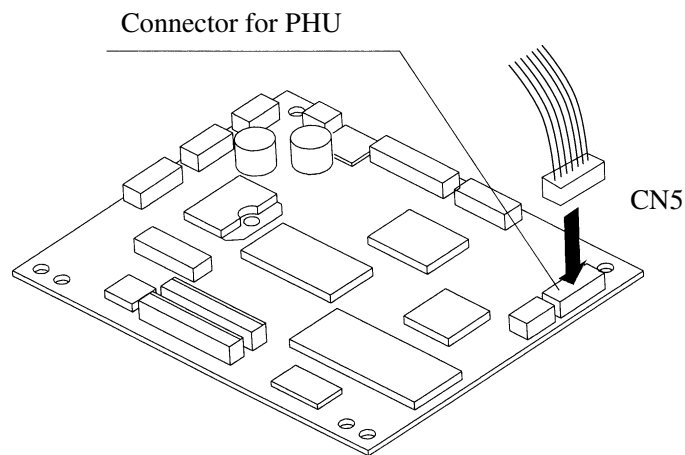

#### 4.10 Paper Near End Function (When Using the PHU)

If the paper is running out, the PNE sensor informs the host computer that the paper is running out. You can adjust the printable amount left after PNE has been detected, up to about  $\phi 50$  of paper roll.

1. Loosen the screw and slide the PNE sensor position forward or backward. When you slide the PNE sensor away from the paper roller, the printable amount left after PNE has been detected will be increased.
2. When replacing the paper, replace it according to the procedure in "4.3 Inserting the Paper."

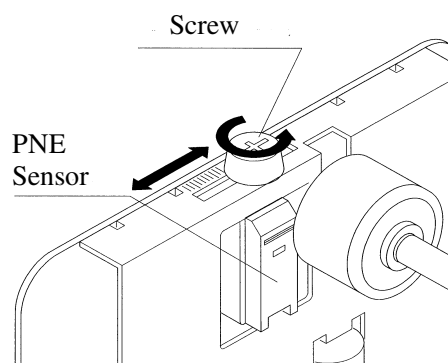

#### 4.11 Auto-Loading Function

This printer has a function to automatically set the paper. When the paper is set and the paper end sensor and paper near end sensor are not detected, and the head-up lever is lowered, the paper will be automatically fed by a constant amount in about 1 second.

If the paper is not automatically fed, remove the paper from the paper insertion slot and try again.

You can use the DIP switch to enable/disable the function. If disabled, auto-loading will not be performed.

#### CAUTION:

- 1) When auto-loading is being activated, do not touch the paper roll, because it could result in a paper feed failure or cause the paper to be one-sided.
- 2) Be sure to set the paper until it comes into contact with the platen roller; otherwise, the paper cannot be fed and the printing head could be damaged.

#### 4.12 Self-Print Function

This unit has a function to perform preset printing. Turn on the power with the FEED switch held down. It will print the ROM version, DIP switch state, characters used, etc.

#### CAUTION:

Do not use this function when the paper roll is running out.

#### 4.13 Presenter Control

This unit feeds in paper while printing or transporting paper.

After having operated the auto cutter, the unit delivers out the paper.

The next printing operation does not start until the paper ejected is removed.

(Printing is halted.)

#### CAUTION:

Do not approach your face or hand toward the Presenter's paper output slot while the paper is being output.

## 5. DIP SWITCH SETTING

### 5.1 Location of DIP Switch

The following figure clearly shows where the DIP switches are.

Any settings made while the power is turned on will not take effect. Turn the power on after you set the DIP switches.

1. Turn off the power.
2. Remove the DIP switch cover screw. (Be careful not to lose the screw.)
3. Slide the cover towards you and lift it to remove (see arrows in the figure).
4. Set the DIP switches.
5. After you have made the required settings, reattach the cover and screw.

#### CAUTION:

- 1) The DIP switch cover has sharp edges. Be careful not cut your fingers.
- 2) The screw is an M 2x3mm type. Do not use any other type. If you do lose it, replace it with the same type. Do not use screws that are longer than 3mm.
- 3) Always turn off the power before setting. If you make settings while the power is on, the unit may become faulty.
- 4) Do not use anything sharp and pointy to set the DIP switches.
- 5) Always set the switches that have been specified as disabled to OFF (the setting that existed when shipped).
- 6) Do not use the unit while the DIP switch cover is removed.

Dip Switches

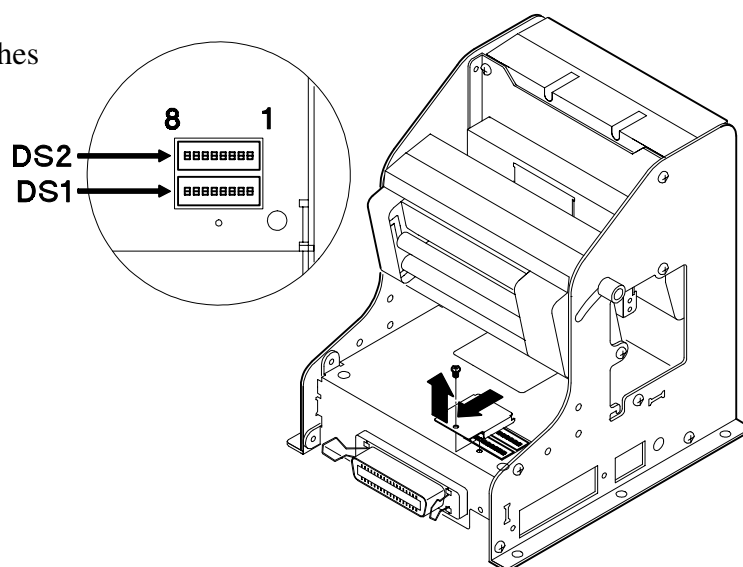

## 5.2 DIP Switch Function

### DIP switch 1 (DS1)

No.	Function	ON	OFF	Upon Shipment
DS1- 1	Auto cutter	Enabled	Disabled	ON
2	CR switching	LF operation	Ignored	OFF
3	Printing density	Combination with DS2-6. See Table 2.		OFF
4	DTR-DSR/XON-XOFF	XON-XOFF	DTR-DSR	OFF
5	Baud rate and parity setting	See Table 1.		OFF
6	Baud rate and parity setting			OFF
7	Baud rate and parity setting			OFF
8	Baud rate and parity setting			OFF

### DIP switch 2 (DS2)

No.	Function	ON	OFF	Upon Shipment
1	PNE function	Enabled	Disabled	ON•
2	Reserved			ON
3	Reserved			ON
4	Auto-loading	Enabled	Disabled	ON
5	Paper selection	Normal thermal paper	Dedicated thermal paper (Black mark)	ON
6	Print density	Combination with DS1-3. See Table 2.		ON
7	Data length	8 Bits	7 Bits	ON
8	Not used			ON

\* With the type U model (North American type), the DIP switches marked are set to OFF.

**Table 1 Baud rate and parity setting**

DS1-8	DS1-7	DS1-6	DS1-5	Interface	Parity	Baud Rate
OFF	OFF	OFF	OFF	Parallel input	—	—
OFF	OFF	OFF	ON	Serial input	None	1,200 bps
OFF	OFF	ON	OFF	"	"	2,400 bps
OFF	OFF	ON	ON	"	"	4,800 bps
OFF	ON	OFF	OFF	"	"	9,600 bps
OFF	ON	OFF	ON	"	"	19,200 bps
OFF	ON	ON	OFF	"	Odd	1,200 bps
OFF	ON	ON	ON	"	"	2,400 bps
ON	OFF	OFF	OFF	"	"	4,800 bps
ON	OFF	OFF	ON	"	"	9,600 bps
ON	OFF	ON	OFF	"	"	19,200 bps
ON	OFF	ON	ON	"	Even	1,200 bps
ON	ON	OFF	OFF	"	"	2,400 bps
ON	ON	OFF	ON	"	"	4,800 bps
ON	ON	ON	OFF	"	"	9,600 bps
ON	ON	ON	ON	"	"	19,200 bps

**Table 2 Print density**

DS1-3	DS2-6	Print Density	Level
OFF	OFF	Light	0
OFF	ON	Standard	1
ON	OFF	Dark	2
ON	ON	Darker	3

## 6. PARALLEL INTERFACE

### 6.1 Specifications

- Data input system : 8-bit parallel (DATA0 to DATA7)
- Control signals :  $\overline{\text{ACK}}$ ,  $\overline{\text{BUSY}}$ ,  $\overline{\text{STROBE}}$ ,  $\overline{\text{FAULT}}$ ,  $\overline{\text{PE}}$ ,  $\overline{\text{RESET}}$
- Applicable connectors : Printer side : 57LE-40360 (Anphenol) or its equivalent  
Cable side : 57-30360 (Anphenol) or its equivalent

### 6.2 Connector's Pin Configuration

No.	Signal Name	No.	Signal Name
1	$\overline{\text{STROBE}}$	19	TWISTED PAIR GND
2	DATA 0	20	↑
3	DATA 1	21	↑
4	DATA 2	22	↑
5	DATA 3	23	↑
6	DATA 4	24	↑
7	DATA 5	25	↑
8	DATA 6	26	↑
9	DATA 7	27	↑
10	$\overline{\text{ACK}}$	28	↑
11	$\overline{\text{BUSY}}$	29	↑
12	$\overline{\text{PE}}$	30	↑
13		31	$\overline{\text{RESET}}$
14		32	$\overline{\text{FAULT}}$
15		33	
16		34	
17	FRAME GND	35	
18		36	

## 6.3 Input and Output Signals

### 6.3.1 Input and Output Signals

(1) Input signals to the printer

- DATA : 8-bit parallel signal (Active: "High")
- STROBE : Strobe signal to read the 8-bit data (Active: "Low")
- RESET : Signal to reset the entire printer (Active: "Low"); 1 ms or more

(2) Output signals from the printer

- ACK : 8-bit data request signal. A pulse signal to be output at the end of the BUSY signal (Active: "Low")
- BUSY : Signal to indicate that the printer is busy. Input new data when it is "Low." (Active: "High")
- FAULT : Turned to "Low" when the printer has an alarm. At this time, all the control circuits in the printer stop. (Active: "Low")
- PE : Output if the printing paper has run out or is running out. (Active: "High")

### 6.3.2 Electrical Characteristics

- (1) Input signal level  
 All the input signals are at the TTL level.  
 High level --- 2.0 V at minimum  
 Low level --- 0.8 V at maximum
- (2) Output signal level  
 All the output signals are at the TTL level.  
 High level --- 2.4 V at minimum  
 Low level --- 0.4 V at maximum
- (3) Input and output conditions  
 The STROBE and RESET input signals are pulled up at 3.3kΩ, and the other input signals at 50kΩ, respectively.

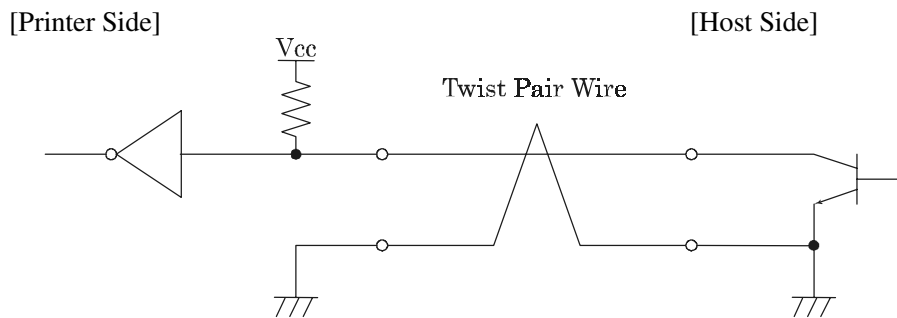

All the output signals are pulled up at 50kΩ.

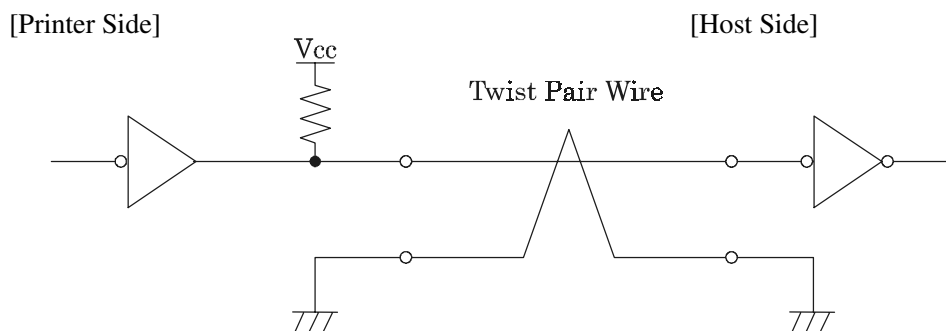

### 6.3.3 Timing Chart

Data Input and Print Timings

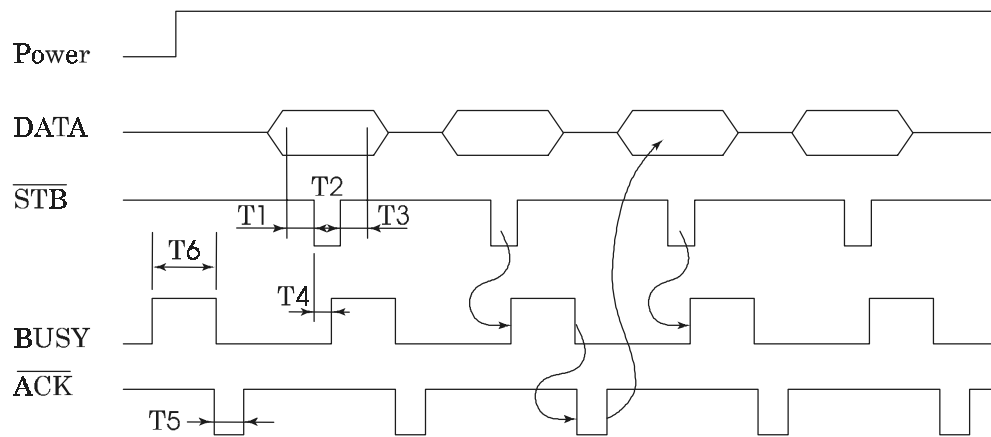

$T_1, T_2, T_3$	0.5 $\mu\text{s}$ MIN
$T_4$	270 ns MAX
$T_5$	2.3 $\mu\text{s}$ TYP
$T_6$	500 ms MIN (At power-on)

### 6.3.4 Data Receiving Control

The data can be received from the host when the BUSY signal is at "Low," but cannot be received when it is "High."

### 6.3.5 Buffering

The host side is immediately freed, because 4 KB data can be buffered.

## 7. SERIAL INTERFACE

### 7.1 Specifications

- (1) Synchronous system : Asynchronous
- (2) Baud rate : 1,200, 2,400, 4,800, 9,600, 19,200 bps (Selected by the user)
- (3) 1-word configuration
  - Start bits : 1 bit
  - Data bits : 8 bits or 7 bits (Setting upon shipment)
  - Parity bits : Odd, even, or no parity (Selected by the user)
  - Stop bits : 1 bit or more
- (4) Signal polarity
  - RS-232C
    - Mark = Logic "1" (-3 ~ -12 V)
    - Space = Logic "0" (+3 ~ +12 V)
- (5) Received data (RXD signal)
  - Mark = 1
  - Space = 0
- (6) Reception control (DTR signal)
  - Mark : Data not transferable
  - Space : Data transferable
- (7) Transmission control (TXD signal)
  - DC1 code(11H) X-ON : Data receivable
  - DC3 code(13H) X-OFF : Data not receivable

### 7.2 Connector's Pin Configuration

No.	Signal Name	Input/Output	Function
1	FG		Frame Ground
7	GND		Signal Ground
3	RXD	Input	Received Data
20	DTR	Output	Printer BUSY Signal
2	TXD	Output	Transmitted Data
6	DSR	Input	Data Set Ready

- [Note] 1. The RS-232C signals are based on the EIA RS-232C.  
 2. The received data should be always maintained in the Mark status when no data is being transferred.

Applicable connectors (D-Sub connectors)

Printer side : 17LE-13250 (Anphenol) or its equivalent

Cable side : 17JE-23250 (Anphenol) or its equivalent

## 7.3 Input and Output Signals

### 7.3.1 Input and Output Signals

(1) RXD

Serial received data signal. If a framing error, overrun error, or parity error takes place, the relevant data will be printed as "?".

(2) DTR

Write the data or a command when this signal is Ready. If you write at Busy, the previous data will be ignored, resulting in an overrun error. The data can be written in the input buffer even during printing. Busy is also issued at power-on, during test printing, at on-line, or at reset.

(3) TXD

If the remaining capacity of the input buffer comes to 128 bytes or less while receiving the data, DC3(13H) will be output as a data not receivable signal. If the remaining capacity comes to 256 bytes or more, DC1(11H) will be output to the host side as a data receivable signal.

When sending the status information, it is confirmed that DSR is a space prior to sending the data, if DTR/DSR control has been selected. If DTR/DSR control has not been selected, the data will be sent, ignoring the DSR signal.

(4) FG

Ground for the case

(5) GND

Common ground for the circuits

### 7.3.2 Data Configuration

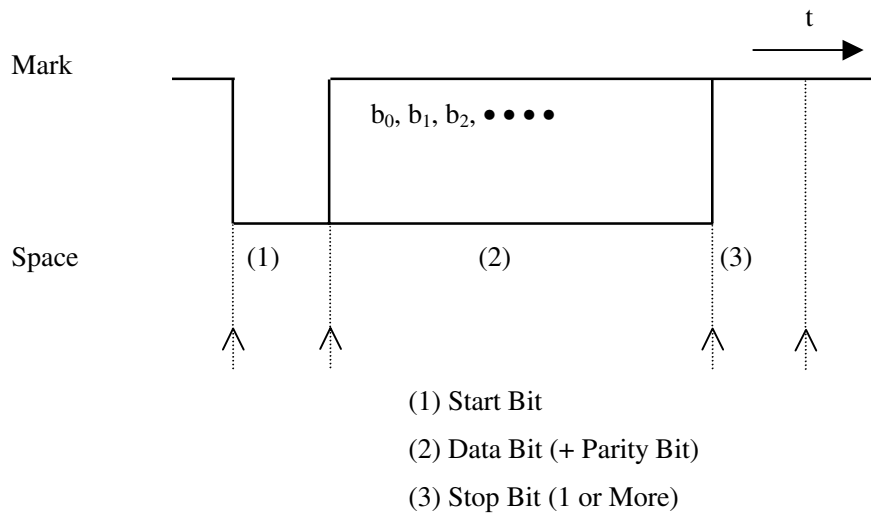

#### (1) Start bit

The system reads the status again after a lapse of 1/2 bit from a fall edge from the mark to space, and if it is a space, this bit will be recognized as the start bit.

If it is a mark, the system will not recognize the bit as the start bit and try to detect the start bit again without judging it as an error.

#### (2) Data bits + Parity bit

The system samples the data bits and parity bit for the 1 bit worth of time from 1/2 start bit and assumes the then status as the data for the relevant bits. The bits are called Bit 0, Bit 1, ..., Parity bit, counting from the one closest to the start bit.

#### (3) Stop bit

The stop bit is the Mark level of 1 bit or more. If a space is detected in detecting the stop bit, a framing error will result.

### 7.3.3 Error Detection

The system detects a parity, framing, or overrun error. If an error is detected, the relevant data will be stored in the buffer as "?".

#### (1) Parity error

With a parity check specified, if an error is detected at parity check time, the relevant data will be stored in the buffer as "?".

#### (2) Framing error

This error results if the Space status is detected at stop bit detection time. The relevant data will be stored in the buffer as "?".

#### (3) Overrun error

If an overrun error is detected, the relevant data will be stored in the buffer as "?".

### 7.3.4 Data Receiving Control

If DTR/DSR control has been selected, the data from the host side will be received when the BUSY signal is at "Low," but not received when at "High." If DTR/DSR has not been selected, the data from the host side will be received after sending XON, but not after sending XOFF.

### 7.3.5 Buffering

To transfer the data to the input buffer, there are two control signals available: DTR signal and TXD signal. The host side is immediately freed, since the data can be buffered up to 4 KB.

- (1) DTR signal (See 7.3.1-(2))
- (2) TXD signal (See 7.3.1-(3))

### 7.3.6 Electrical Characteristics

RS-232C Circuit

Input (RXD, DSR)

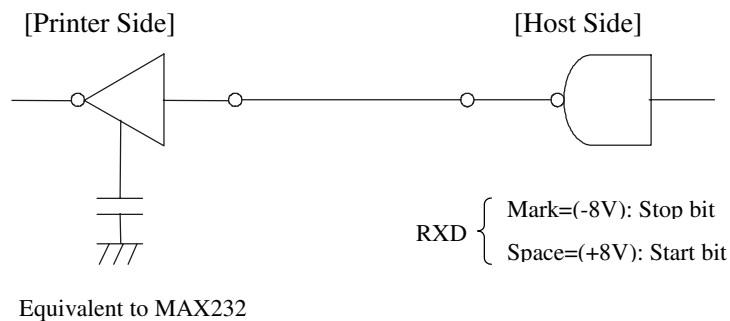

Output (TXD, DTR)

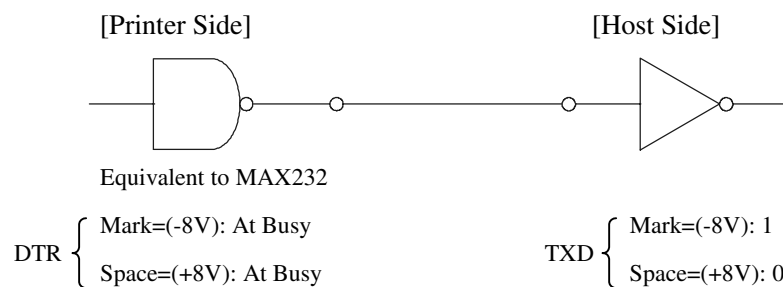

## 8. POWER CONNECTOR

This connector is to supply the power from the special AC adapter (31AD).

### Connector's Pin Configurations

No.	Function
1	+24V
2	GND
3	N.C
SHELL	FG

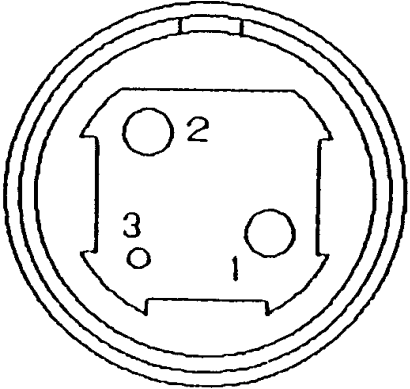

Connector used : TSC7960-53-2010 (Made by HOSHIDEN) or its equivalent

Applicable connector : TSC8927-63-1100 (Made by HOSHIDEN) or its equivalent  
TSC8927-53-1100 (Made by HOSHIDEN) or its equivalent

### CAUTION:

- 1) Be sure to use the specified AC adapter. Use of any other power source could cause trouble to or break the printer.
- 2) Do not connect the power source with different polarity.
- 3) After using the printer or when not using it for a long period of time, be sure to unplug the AC adapter from a plug socket for your safety.

## **9. MAINTENANCE AND SERVICE**

For the information on maintenance and service, please contact our dealer.

## 10. PRINT CONTROL FUNCTIONS

### 10.1 Commands List

	Control Code	Function	Code	Page
1	HT	Horizontal tab	09H	40
2	LF	Printing and paper feed	0AH	40
3	CR	Print	0DH	41
4	ESC SP	Setting the right space amount of the character	1BH 20H n	41
5	ESC !	Collective specifying printing mode	1BH 21H n	42
6	ESC %	Specifying/canceling download character set	1BH 25H n	44
7	ESC &	Defining download characters	1BH 26H s n m [a p1 p2 ... psxa] m-n+1	45
8	ESC *	Specifying the bit image mode	1BH 2AH m n1 n2 [d]k	47
9	ESC -	Specifying/canceling underline	1BH 2DH n	49
10	ESC 2	Specifying 1/6-inch line feed rate	1BH 32H	49
11	ESC 3	Setting line feed rate of minimum pitch	1BH 33H n	50
12	ESC =	Data input control	1BH 3DH n	51
13	ESC @	Initializing the Printer	1BH 40H	52
14	ESC D	Setting horizontal tab position	1BH 44H [n]k 00H	53
15	ESC E	Specifying/canceling highlighting	1BH 45H n	54
16	ESC G	Specifying/canceling double printing	1BH 47H n	55
17	ESC J	Printing and feeding paper n/203 inch	1BH 4AH n	55
18	ESC R	Selecting the international character set	1BH 52H n	56
19	ESC V	Specifying/Canceling 90°-right- turned Characters	1BH 56H n	57
20	ESC a	Aligning the characters	1BH 61H n	58
21	ESC c3	Selecting the paper near end sensor valid for a paper end	1BH 63H 33H n	59
22	ESC c4	Selecting the paper near end sensor valid for print stop	1BH 63H 34H n	59
23	ESC c5	Enabling/disabling the panel switches	1BH 63H 35H n	60
24	ESC d	Printing and feeding the paper by n lines	1BH 64H n	60
25	ESC i	Activating auto cutter	1BH 69H	61
26	ESC m	Activating auto cutter	1BH 6DH	62
27	ESC p	NOP		
28	ESC t	Selecting the character code table	1BH 74H n	63
29	ESC u	NOP		
30	ESC v	Transmitting the printer status (Serial type)	1BH 76H n	64
31	ESC {	Specifying/canceling the inverted characters	1BH 7BH n	65
32	ESC \$	Specifying the absolute positions	1BH 24H n1 n2	66
33	ESC \	Specifying the relative positions	1BH 5C n1 n2	67
34	GS S	Detection of black mark (M model)	1DH 53H	67
35	GS k	Printing the bar code	1DH 6BH n ["d"]k 00H	68
36	GS w	Selecting the horizontal size (scale factor) of bar code	1DH 77H n	72
37	GS h	Selecting the height of the bar code	1DH 68H n	73
38	GS H	Selecting of print position of HRI code	1DH 48H n	74

	Control Code	Function	Code	Page
39	GS f	Selecting the font of HRI code	1DH 66H n	75
40	GS *	Defining the download, bit image	1DH 2AH n1 n2 [d] n1 ×n2×8	76
41	GS /	Printing the download, bit image	1DH 2FH m	78
42	GS :	Starting/ending macro definition	1DH 3AH	79
43	GS ^	Executing the macro	1DH 5EH n1 n2 n3	80

Notes 1. n, n1, n2, n3, n4, n5, n6, m, a, s, p, d, N1, N2, N3,N4, and N5 in the table are parameters for each commands.

2. [ ]k in the table denotes k-times of repeat.

3. Characters shown in “ ” are the ASCII characters.

## 10.2 Command Details

### 10.2.1 Description of Items

XXXX

ALL

---

[Function]	Command Function
[Code]	A sequence of code constituting a command is represented in hexadecimal number for < >H, binary number for < >B, and decimal number for < >, respectively; [ ]k represents a repeat count of k-times.
[Range]	Describes an argument value (Setting range) for the command.
[Outline]	Describes a command outline.
[Caution]	Describes a caution as required.
[Default]	Describes an initial value for the command when accompanied by an argument.
[See Also]	Describes the associated commands for use.
[Sample Program]	Describes a coding example in the Q-BASIC sample program. This example is only for your reference and differs depending on the language used, version, and so on. For details, see the manual for the language used.

## 10.2.2 Details

### HT

[Function]	Horizontal Tab
[Code]	<09>H
[Outline]	Shifts the printing position to the next horizontal tab position. <ul style="list-style-type: none"> <li>Ignored when the next horizontal tab position has not been set.</li> </ul>
[Caution]	<ul style="list-style-type: none"> <li>The horizontal tab position is set by ESC D.</li> <li>Initial setting of the horizontal tab position is each 8 characters in 9th, 17th, 25th, columns.</li> </ul>
[See Also]	ESC D
[Sample Program]	

```
LPRINT "0123456789012345678901" ;
LPRINT CHR$ (&HA) ;
LPRINT CHR$ (&H9) + "AAA" ;
LPRINT CHR$ (&H9) + "BBB" ;
LPRINT CHR$ (&HA);
LPRINT CHR$ (&H1B) + "D" ;
LPRINT CHR$ (3) + CHR$ (7) + CHR$ (14) + CHR$ (0) ;
LPRINT CHR$ (&H9) + "AAA" ;
LPRINT CHR$ (&H9) + "BBB" ;
LPRINT CHR$ (&H9) + "CCC" + CHR$ (&HA) ;
```

[Print Results]

```
012345678901234567890 1
      AAA      BBB      ← Initially set horizontal tab
AAA BBB      CCC      ← When set to the 4th, 8th, and 15th digits
```

### LF

[Function]	Printing and Paper Feed
[Code]	<0A>H
[Outline]	Prints data inside the input buffer and feeds lines based on the line feed amount having been set. <ul style="list-style-type: none"> <li>The head of the line becomes the next print starting position.</li> </ul>
[See Also]	ESC 2, ESC 3

[Sample Program]

```
LPRINT "AAA" + CHR$ (&HA) ;
LPRINT "BBB" + CHR$ (&HA) ;
LPRINT CHR$ (&HA) ;
LPRINT "CCC" + CHR$ (&HA) ;
```

[Print Results]

```
AAA      ← Print and line feed
BBB      ← Print and line feed
          ← Line feed only
CCC      ← Print and line feed
```

---

## CR

---

[Function]	Print												
[Code]	<0D>H												
[Outline]	1) When DS1-2 is OFF: This command is ignored. 2) When DS1-2 is ON: With data held inside the internal print buffer, printing and line feed are performed. Without data inside the internal print buffer, however, no printing is performed.												
[See Also]	LF												
[Sample Program]	<pre>LPRINT "AAA" + CHR\$ (&amp;HD); LPRINT "BBB" + CHR\$ (&amp;HD); LPRINT CHR\$ (&amp;HD); LPRINT "CCC" + CHR\$ (&amp;HD);</pre>												
	<table> <tr> <td>[Print Results]</td> <td>AAA</td> <td>← Print and line feed</td> </tr> <tr> <td></td> <td>BBB</td> <td>← Print and line feed</td> </tr> <tr> <td></td> <td></td> <td>← Line feed only</td> </tr> <tr> <td></td> <td>CCC</td> <td>← Print and line feed</td> </tr> </table>	[Print Results]	AAA	← Print and line feed		BBB	← Print and line feed			← Line feed only		CCC	← Print and line feed
[Print Results]	AAA	← Print and line feed											
	BBB	← Print and line feed											
		← Line feed only											
	CCC	← Print and line feed											

---

## ESC SP n

---

[Function]	Setting the right space amount of the character
[Code]	<1B>H<20>H<n>
[Range]	{0 ≤ n ≤ 20} Data is described in Hex code.
[Outline]	The rightward space amount is set in dot unit (1/203 inch unit). In the initial value, it is n=0.
[Caution]	The rightward space amount in double wide mode is made double of the set volume.
[Default]	n = 0
[Sample Program]	<pre>LPRINT CHR\$ (&amp;H1B) + " " + CHR\$ (0); LPRINT "AAAAA" + CHR\$ (&amp;HA); LPRINT CHR\$ (&amp;H1B) + " " + CHR\$ (1); LPRINT "AAAAA" + CHR\$ (&amp;HA); LPRINT CHR\$ (&amp;H1B) + " " + CHR\$ (12); LPRINT "AAAAA" + CHR\$ (&amp;HA);</pre>
[Print Results]	<pre>A A A A A ← 0-dot space A A A A A ← 1-dot space A A A A A ← 12-dot space</pre>

**ESC ! n**

[Function] Collective Specifying Printing Mode

[Code] <1B>H<21>H<n>

[Range] {0 ≤ n ≤ FF} Data is described in Hex code.

[Outline] Printing mode is assigned. Each n bit indicates the following:

Bit	Function	Value	
		0	1
0	Character Font	Font A	Font B
1	Undefined		
2	Undefined		
3	High-lighting	Canceled	Specified
4	Double height	Canceled	Specified
5	Double width	Canceled	Specified
6	Undefined		
7	Underline	Canceled	Specified

- [Caution]
- With double height and double width being specified simultaneously, double wide and double high characters are consisted.
  - An underline is attached to the full character width, which, however, is not attached to the part having been skipped by the horizontal tab.  
Neither is it attached to 90°-right-turned characters.
  - The underline width is as having been specified by <ESC - >.  
(The default setting is 1 dot width. )
  - Specification with this command is invalid to Kanji, except specification and cancellation of highlighting
  - In case that double wide character and normal character exist in same one line, the layout of underline is consistent one.

[Default] n = 0

[See Also] ESC E, ESC -

[Sample Program]

```
LPRINT CHR$ (&H1B) + "!" + CHR$ (&H00) + "H" ;
LPRINT CHR$ (&H1B) + "!" + CHR$ (&H01) + "H";
LPRINT CHR$ (&H1B) + "!" + CHR$ (&H08) + "H";
LPRINT CHR$ (&H1B) + "!" + CHR$ (&H10) + "H";
LPRINT CHR$ (&H1B) + "!" + CHR$ (&H20) + "H";
LPRINT CHR$ (&H1B) + "!" + CHR$ (&H80) + "H";
LPRINT CHR$ (&H1B) + "!" + CHR$ (&HB9) + "H";
LPRINT CHR$ (&HA) ;
```

[Print Results]

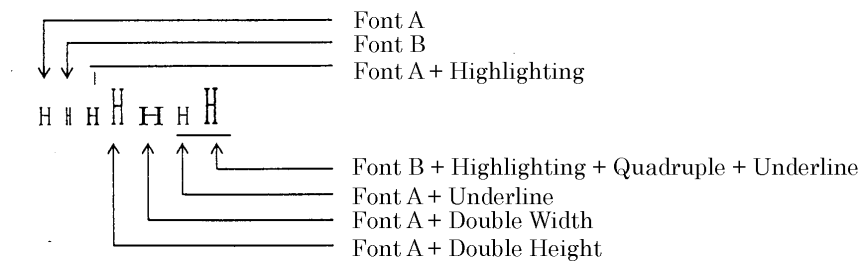

## ESC % n

[Function] Specifying/Canceling Download Character Set

[Code] <1B>H<25>H<n>

[Range] {0 ≤ n ≤ FF} data is described in Hex code.

[Outline] Specifying/canceling download characters.  
Further, only the lowest bit (n0) is valid for n.  
The lowest bit (n0) indicates the following.

n0	Function
0	Canceling download character set
1	Specifying download character set

[Caution] Download characters and download bit images can not be defined simultaneously.

[Default] n = 0

[See Also] ESC &

[Sample Program]

```

GOSUB SETCHR                                DATA 6
LPRINT CHR$ (&H1B) + "%" + CHR$ (0) ;      DATA &HFF, &H80, &H00
LPRINT "@A" + CHR$ (&HA) ;                 DATA &H80, &H80, &H00
LPRINT CHR$ (&H1B) + "%" + CHR$ (1) ;      DATA &H80, &H80, &H00
LPRINT "@A" + CHR$ (&HA) ;                 DATA &H80, &H80, &H00
END                                           DATA &HFF, &HFF, &HFF
SETCHR :                                     DATA &HFF, &HFF, &HFF
LPRINT CHR$ (&H1B) + "&" ;                   DATA 12
LPRINT CHR$ (3) + "@" + "A" ;               DATA &HFF, &HFF, &HFF
FOR J=1 TO 2                                 DATA &H80, &H07, &HF9
READ REP                                     DATA &H80, &HFF, &HF9
LPRINT CHR$ (REP) ;                          DATA &H87, &HFE, &H01
FOR I=1 TO REP*3                             DATA &H9F, &H06, &H01
READ D                                       DATA &HF8, &H06, &H01
LPRINTCHR$ (D) ;                             DATA &HF8, &H06, &H01
NEXT I                                       DATA &H9F, &H06, &H01
NEXT J                                       DATA &H87, &HFE, &H01
RETURN                                       DATA &H80, &HFF, &HF9
                                           DATA &H80, &H07, &HF9
                                           DATA &HFF, &HFF, &HFF
    
```

[Print Results]

@ A ← Internal Character Set

☐ ▯ ← Download Character

---

**ESC & s n m [ a [ p ] s x a ] m - n + 1**

---

[Function]	Defining Download Character
[Code]	<1B>H<26>H<s><n><m> [<a><p1><p2>••<psxa>]m-n+1
[Range]	{s = 03} {20 (Hex) ≤ n ≤ m ≤ 7E (Hex)} {0 ≤ a ≤ 0C(Hex)} (Font A) {0 ≤ a ≤ 0A(Hex)} (Font B)
[Outline]	<p>Defines the font of download characters of alphanumeric characters.</p> <ul style="list-style-type: none"> <li>• "s" indicates the number of bytes in vertical direction.</li> <li>• "n" indicates the start character code and m the end character code. To define only one character, set n=m.</li> <li>• Character codes definable includes 95 ASCII codes in total between &lt;20&gt;H~&lt;7E&gt;H.</li> <li>• "a" indicates the number of dots in horizontal direction for definition.</li> <li>• "p" is the data to be defined, which indicate a pattern equal to "a" dot in horizontal direction from the left end. The rest of the pattern on the right side is filled with space. The rest of data to be defined is s x a.</li> <li>• Download characters thus defined remain valid until redefinition, ESC @ execution, GS * execution, or power OFF is practiced.</li> </ul>
[Caution]	Download characters and download bit images can not be defined simultaneously. Running this command clears the definition of the download bit image.
[Default]	Same as the internal character set

[Example]

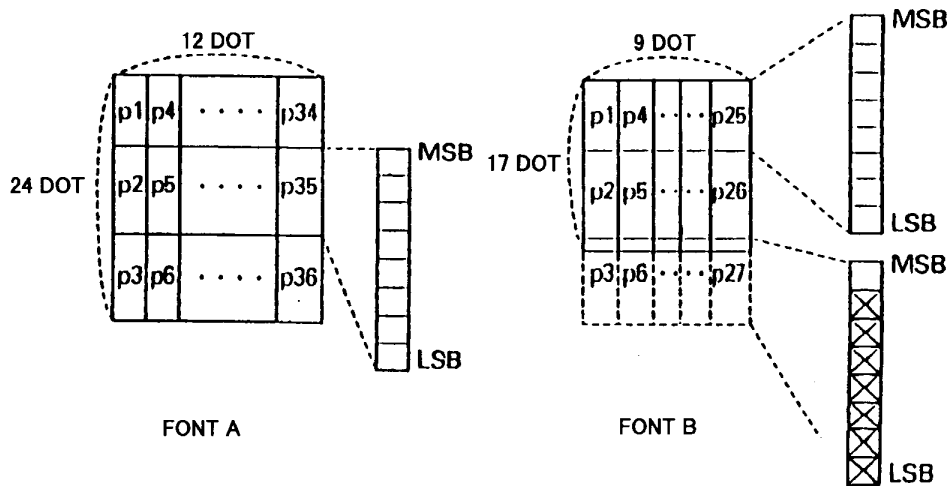

Create each data bit by setting "1" for a printed dot and "0" for an unprinted dot.

[Sample Program]

[Print Results]

See Sample Program and Print Results for ESC % on Page 44.

---

**ESC \* m n1 n2 [ d ] k**

---

[Function] Specifying the Bit Image Mode

[Code] <1B>H<2A>H<m><n1><n2> [ <d> ] k

[Range] {m= 0, 1, 32, 33 bit image mode (See the table below.)}  
 {0 ≤ n1 ≤ FF(Hex)}  
 {0 ≤ n2 ≤ 03(Hex)}  
 {0 ≤ d ≤ FF(Hex)}  
 {k = n1 + FF(Hex) × n2 (m = 0, 1)}  
 {k = (n1 + FF(Hex) × n2) × 3 (m = 32, 33)}

[Outline] According to the number of dots specified in n1, n2, specify the bit image of mode n.

- The No. of dots printed is divided by 256, whose quotient is taken as n2 and residual as n1.
- The total no. of dots printed in the bit image is equal to n1 + (256 × n2).
- When bit image data have been input in excess of dot position of one line(448 dots), the excess data are discarded.
- d is bit image data, the bits subject to printing are taken as "1" and those not as "0".
- The bit image modes specified by m are shown as follows:

m(Hex)	Mode	Vertical Direction		Horizontal Direction	
		No. of Dots	Dot Density	Dot Density	Max. No. of Dots
0	8-dots single density	8	67 DPI	101 DPI	288
1	8-dots double density	8	67 DPI	203 DPI	576
20	24-dots single density	24	203 DPI	101 DPI	288
21	24-dots double density	24	203 DPI	203 DPI	576

[Caution]

- When the values set in m (bit image mode) are out of the above range, the data following after n1 is processed as normal printing data.
- After completion of bit image printing, printer returns to normal data processing mode.

[Example]

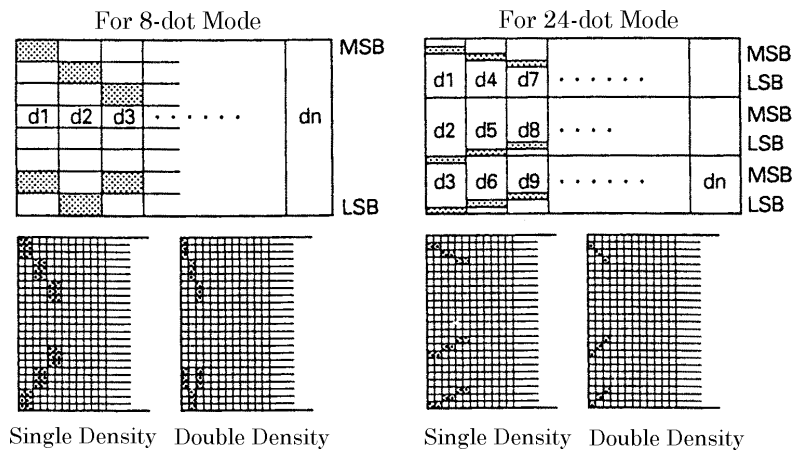

[Sample Program]

```

LPRINT CHR$ (&H1B) + "*";
LPRINT CHR$ (0) + CHR$ (20) + CHR$ (0);  IMG1 :
GOSUB IMG1                                LPRINT  CHR$ (&HFF);
LPRINT CHR$ (&HA);                          FOR I=1 TO 18
LPRINT CHR$ (&H1B) + "*";                    LPRINT CHR$ (&H85);
LPRINT CHR$ (1) + CHR$ (20) + CHR$ (0);      NEXT I
GOSUB IMG1                                LPRINT  CHR$ (&HFF);
LPRINT CHR$ (&HA);                          RETURN
LPRINT CHR$ (&H1B) + "*";                    IMG2;
LPRINT CHR$ (32) + CHR$ (20) + CHR$ (0);     LPRINT  CHR$ (&HFF);
GOSUB IMG2                                LPRINT  CHR$ (&HFF);
LPRINT CHR$ (&HA);                          LPRINT  CHR$ (&HFF);
LPRINT CHR$ (&H1B) + "*";                    FOR I=1 TO 18
LPRINT CHR$ (33) + CHR$ (20) + CHR$ (0);     LPRINTCHR$ (&H80);
GOSUB IMG2                                LPRINTCHR$ (&H00);
LPRINT CHR$ (&HA);                          LPRINTCHR$ (&H05);
END                                          NEXT I
                                           LPRINT  CHR$ (&HFF);
                                           LPRINT  CHR$ (&HFF);
                                           LPRINT  CHR$ (&HFF);
                                           RETURN
    
```

[Print Results]

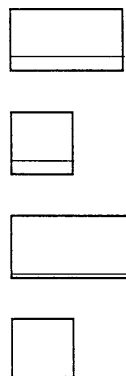

## ESC – n

[Function] Specifying/Canceling Underline  
 [Code] <1B>H<2D>H<n>  
 [Range] {0 ≤ n ≤ 02} data is described in Hex code.  
 [Outline] Specifying/canceling an underline.

•Types of underlines by n value are shown below:

n (Hex)	Type
0	Canceling an underline.
1	Specifying an underline for 1-dot width.
2	Specifying an underline for 2-dots width.

[Caution]
 

- An underline is attached to the full character width. It is, however, not attached to the part having been skipped by horizontal tab command.
- An underline is not attached to a 90 ° - right-turned characters.
- Specification/cancellation with this command is invalid to Kanji.

[See Also] ESC !, FS –

[Sample Program]

```
LPRINT CHR$ (&H1B) + "-" + CHR$ (0) ;
LPRINT "AAAAA" ;
LPRINT CHR$ (&H1B) + "-" + CHR$ (1) ;
LPRINT "AAAAA" + CHR$ (&HA) ;
```

[Print Results]

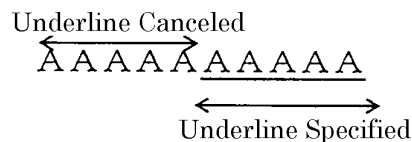

## ESC 2

[Function] Specifying 1/6-inch Line Feed Rate  
 [Code] <1B>H<32>H  
 [Outline] The line feed rate per line is specified by 1/6 inch.

[Sample Program]

```
LPRINT "AAAAA" + CHR$ (&HA) ;
LPRINT CHR$ (&H1B) + "3" + CHR$ (0) ;
LPRINT "AAAAA" + CHR$ (&HA) ;
LPRINT CHR$ (&H1B) + "3" + CHR$ (50) ;
LPRINT "AAAAA" + CHR$ (&HA) ;
LPRINT CHR$ (&H1B) + "2" ;
LPRINT "AAAAA" + CHR$ (&HA) ;
LPRINT "AAAAA" ;
LPRINT CHR$ (&H1B) + "J" + CHR$ (100) ;
LPRINT "AAAAA" + CHR$ (&HA) ;
LPRINT "AAAAA" + CHR$ (&HA) ;
```

[Print Results]

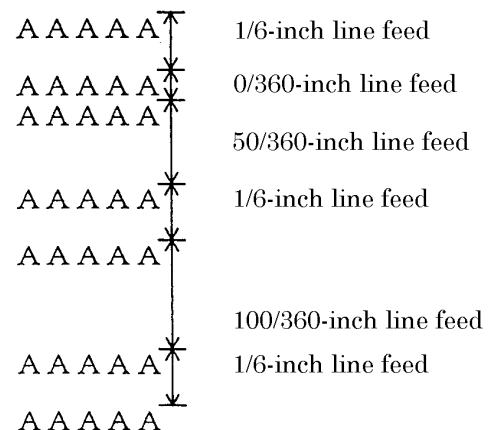

---

## ESC 3 n

---

[Function]	Setting Line Feed Rate of Minimum Pitch
[Code]	<1B>H<33>H<n>
[Range]	{0 ≤ n ≤ FF} Data is described in Hex code.
[Outline]	The line feed rate per line is specified by n/360 inch. Since an actual mechanical pitch is 1/203 inch, it is internally converted approximate to the value specified with this command.
[Default]	• The initial value is n = 60 (1/6 inch) (18H), being 4.23 mm line feed rate.
[Sample Program]	[Print Results]

See Sample Program and Print Results for ESC 2 on Page 49.

## ESC = n

[Function] Data Input Control

[Code] <1B>H<3D>H<n>

[Range] {0 ≤ n ≤ FF} Data is described in Hex code.

[Outline] Selecting equipment in which data input from the host is effective.

- Each bit of n indicates as follows:

Bit	Equipment	Value	
		0	1
0	Printer	Invalid	Valid
1	Not defined		
2	Not defined		
3	Not defined		
4	Not defined		
5	Not defined		
6	Not defined		
7	Not defined		

- When the printer has not been selected, this printer abandons all the received data until it is selected by this command.

[Caution]

- Even when the printer has not been selected, it can become BUSY state through printer operation.
- When the printer is deselected, this printer discards all the data until it is selected with this command.

[Default] • The initial value of n is "1".

[Sample Program]

```
LPRINT "AAAAA" ;
LPRINT CHR$ (&H1B) + "=" + CHR$ (0) ;
LPRINT "aaaaa" + CHR$ (&HA) ;
LPRINT CHR$ (&H1B) + "=" + CHR$ (1) ;
LPRINT "AAAAA" + CHR$ (&HA) ;
```

[Print Results]

```
A A A A A A A A A A
      ↑
      a a a a a is not printed
```

---

## ESC @

---

[Function]	Initializing the Printer
[Code]	<1B>H<40>H
[Range]	Clears data stored in the print buffer and brings various settings to the initial state (Default state).

- [Caution]
- Data inside the internal input buffer are not cleared.
  - Dip switches setting are red once again.

[Sample Program]

```
LPRINT CHR$ (&H1B) + " !" + CHR$ (&H30) ;
LPRINT CHR$ (&H1B) + "V" + CHR$ (1) ;
LPRINT "AAA" + CHR$ (&HA) ;
LPRINT CHR$ (&H1B) + "@" ;
LPRINT "AAA" + CHR$ (&HA) ;
```

[Print Results]

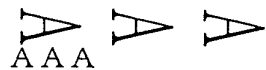

← Each setting are initialized by reset command.

---

## ESC D [ n ] k NUL

---

[Function]	Setting Horizontal Tab Position
[Code]	<1B>H<44>H [ <n> ] k<00>H
[Range]	{0 ≤ n ≤ FFH} {0 ≤ k ≤ 20H} Data is described in Hex code.
[Outline]	<p>Specifying a horizontal tab position.</p> <ul style="list-style-type: none"> <li>• "n" indicates the no. of columns from the beginning to the horizontal tab position. At this time, n= set position- 1 is to be specified. For example, to set the position at 9th column, n=8 is to be specified.</li> <li>• k denotes the number of horizontal tab positions you want to set.</li> <li>• The tab position is set at position where it is "character width x n" from the line beginning. The character width, at this time, includes the rightward space amount. In double wide characters, it is made double of the ordinary case.</li> <li>• Tab positions can be specified are maximum 32. Specifying exceeding this is ignored.</li> <li>• &lt;n&gt; k, which denotes a setting position, is input in the increasing order and ends at &lt;00&gt; H.</li> <li>• ESC D NUL clears all the set tab positions. Following clearing, horizontal tab command is ignored.</li> </ul>
[Caution]	<p>When the data, &lt;n&gt; k, is equal to or smaller than its preceding data, &lt;n&gt; k-1, it is assumed that tab setting is finished. If this is the case, the next data onward will be processed as normal data.</p> <p>When the data, &lt;n&gt; k, exceeds a 1-line print area, set the horizontal tab position, assuming "Set digit position = Maximum print digits + 1." The horizontal tab position does not change even if the character width is altered after setting the horizontal tab position.</p>
[Default]	<ul style="list-style-type: none"> <li>• Initial value is specified for each eight characters (9<sup>th</sup>.17<sup>th</sup>.25<sup>th</sup> columns) of ANK characters.</li> </ul>
[See Also]	HT
[Sample Program]	[Print Results]

See Sample Program and Print Results for HT on Page 40.

## ESC E n

[Function]                    Specifying/canceling highlighting

[Code]                        <1B>H<45>H<n>

[Range]                      {0 ≤ n ≤ FF}    Data is described in Hex code.

[Outline]                    Specifying/canceling the highlighting characters.

- "n" is valid only for the lowest bit (n0).
- Control by the lowest bit (n0) is shown as follows:

n0	Type
0	Canceling highlighting.
1	Specifying highlighting.

- This is effective to all characters.
- Dot configuration of a highlighted character includes one extra dot added at its side.

[Caution]                    • The print result of Double printing and highlight character printing is completely same.

[See Also]                    ESC !

[Example]

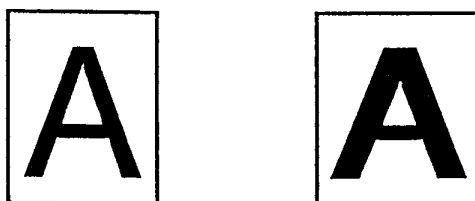

[Sample Program]

```
LPRINT CHR$ (&H1B) + "E" + CHR$ (0) ;
LPRINT "AAABBB" + CHR$ (&HA) ;
LPRINT CHR$ (&H1B) + "E" + CHR$ (1) ;
LPRINT "AAABBB" + CHR$ (&HA) ;
```

[Print Results]

```
AAA BBB ← Highlighting canceled
AAA BBB ← Highlighting canceled
```

---

## ESC G n

---

[Function] Specifying/canceling Double Printing (ESC G n)

[Code] <1B>H<47>H<n>

[Range] {0 ≤ n ≤ FF} Data is described in Hex code.

[Outline] Specifying/canceling the double printing.

- "n" is valid only for the lowest bit (n0).
- Control by n is shown as follows.

n0	Type
0	Canceling double printing.
1	Specifying double printing.

This is effective to all characters.

[Caution] • The print result of Double printing and highlight character printing is completely same.

[See Also] ESC E

[Sample Program]

```
LPRINT CHR$ (&H1B) + "G" + CHR$ (0) ;
LPRINT "AAABBB" + CHR$ (&HA) ;
LPRINT CHR$ (&H1B) + "G" + CHR$ (1) ;
LPRINT "AAABBB" + CHR$ (&HA) ;
```

[Print Results]

A A A B B B ← Highlighting canceled

A A A B B B ← Highlighting canceled

---

## ESC J n

---

[Function] Printing and feeding paper n/203 inch

[Code] <1B>H<4A>H<n>

[Range] {0 ≤ n ≤ FF} Data is described in Hex code.

[Outline] Prints data inside the print buffer and feeds paper by n/360 inch. Since an actual mechanical pitch is 1/203 inch, it is internally converted approximate to the value specified with this command.

- Specified volume does not remain.
- The beginning of the line is to be considered as the next printing start position.
- Initial value is not defined.

[Sample Program]

[Print Results]

See Sample Program and Print Results for ESC 2 on Page 49.

---

## ESC R n

---

- [Function] Selecting the International Character set
- [Code] <1B>H<52>H<n>
- [Range] {0 ≤ n ≤ 0A} Data is described in Hex code.
- [Outline] Depending on the value of n, following character sets are specified.

n(Hex)	Character Set
0	U.S.A.
1	France
2	Germany
3	U.K.
4	Denmark I
5	Sweden
6	Italy
7	Spain
8	Japan
9	Norway
A	Denmark II

- [Default] The initial value of n are shown below.
- When domestic mode is selected : 8(Japan)
  - When international is selected : 0(U.S.A.)
- [See Also] Character Code Table (International Character Set)
- [Sample Program]

```
FOR I=0 TO 10
LPRINT CHR$ (&H1B) + "R" + CHR$ (I) ;
LPRINT " #${[¥]^" ;
LPRINT CHR$ (&H60) + "{¥}~" ;
LPRINT "n=" + STR$ (I) ;
LPRINT CHR$ (&HA) ;
NEXT I
```

- [Print Results]
- ```
#${[\]^`{ }~ n = 0
#â°çš`éùè" n = 1
#šÄÜ`äöüß n = 2
£${[\]^`{ }~ n = 3
#£ÄÜ`æøå n = 4
#ÉÄÜéäöü n = 5
#°\é`àòèì n = 6
£$ ; Ñ¿`"n}~ n = 7
#${[¥]^`{ }~ n = 8
#£ÄÜéæøåü n = 9
#ÉÄÜéæøåü n = 10
```

## ESC V n

[Function]                    Specifying/Canceling 90°-right- turned Characters

[Code]                        <1B>H<56>H<n>

[Range]                      {0 ≤ n ≤ 1}    Data is described in Hex code.

[Outline]                     Specifying/canceling characters 90°-right- turned character.

- "n" means the followings.

| n (Hex) | Condition                               |
|---------|-----------------------------------------|
| 0       | Canceling 90°-right- turned Characters  |
| 1       | Specifying 90°-right- turned Characters |

[Caution]                    • No underlines are attached to 90°-right- turned characters .

[Default]                     • The initial value of n is "0".

[Sample Program]

```
LPRINT CHR$ (&H1B) + "V" + CHR$ (0) ;
LPRINT "AAAAA" ;
LPRINT CHR$ (&H1B) + "V" + CHR$ (1) ;
LPRINT "AAAAA" + CHR$ (&HA) ;
```

[Print Results]

```
90° Rotation Canceled
  ←-----→
AAAAA
  →     →     →     →     →
  ←-----→
90° Rotation Specified
```

## ESC a n

[Function]           Aligning the characters

[Code]               <1B>H<61>H<n>

[Range]             {0 ≤ n ≤ 2}   Data is described in Hex code.

[Outline]            All the printed data within one line are aligned in the specified position.

- Depending on n value, positional alignment is carried out as in the table below:

| n (Hex) | Position            |
|---------|---------------------|
| 0       | Left end alignment  |
| 1       | Centering           |
| 2       | Right end alignment |

[Caution]           • This is valid only when n is inputted at the beginning of line.  
 • The initial value of n is "0".

[Sample Program]

```
LPRINT CHR$ (&H1B) + "a" + CHR$ (0) ;
LPRINT "AAAAA" + CHR$ (&HA) ;
LPRINT CHR$ (&H1B) + "a" + CHR$ (1) ;
LPRINT "AAAAA" + CHR$ (&HA) ;
LPRINT CHR$ (&H1B) + "a" + CHR$ (2) ;
LPRINT "AAAAA" + CHR$ (&HA) ;
```

[Print Results]

|                |           |                 |                      |
|----------------|-----------|-----------------|----------------------|
| A A A A A      | A A A A A | A A A A A       | ↑                    |
| Left-justified | Centered  | Right-justified | Paper Feed Direction |

**ESC c 3 n****(Parallel Interface Only)**

- [Function] Selecting the paper near end sensor valid for a paper end signal output
- [Code] <1B>H<63>H<33>H<n>
- [Range]  $0 \leq n \leq 255$
- [Outline] This command selects at which paper near end sensor a paper end signal should be output. Each bit for n has the following meaning:

| Bit | Position       | Value    |         |
|-----|----------------|----------|---------|
|     |                | 0        | 1       |
| 0   | Paper near end | Disabled | Enabled |
| 1~7 | Undefined      |          |         |

This printer can only select one kind of paper end detection, a paper-near-end sensor. n is valid for the least significant bit (n0).

- [Caution] This command is valid only for the parallel interface.
- [Default] A default of n is what has been set with the DIP switch (DS2-1).
- [Sample Program]

```
LPRINT CHR$(&H1B);"c3";CHR$(0);
.....When outputting the paper-end signal at the paper end
LPRINT CHR$(&H1B);"c3";CHR$(1);
.....When outputting the paper-end signal at the paper near end
```

**ESC c 4 n**

- [Function] Selecting the paper near end sensor valid for print stop
- [Code] <1B>H<63>H<34>H<n>
- [Range]  $0 \leq n \leq 255$
- [Outline] This command selects at which paper near end sensor printing should be stopped. Each bit for n has the following meaning:

| Bit | Position       | Value    |         |
|-----|----------------|----------|---------|
|     |                | 0        | 1       |
| 0   | Paper near end | Disabled | Enabled |
| 1~7 | Undefined      |          |         |

This printer can only select one kind of paper-end detection, a paper-near-end sensor. n is valid for the least significant bit (n0).

- [Default] A default of n is what has been set with the DIP switch (DS2-1).
- [Sample Program]

```
LPRINT CHR$(&H1B);"c4";CHR$(0);
.....When stopping printing at the paper end
LPRINT CHR$(&H1B);"c4";CHR$(1);
.....When stopping printing at the paper near end
```

**ESC c 5 n**

[Function] Enabling/Disabling Panel Switches  
 [Code] <1B>H<63>H<35>H<n>  
 [Range] {0 ≤ n ≤ FF} Data is described in Hex code.  
 [Outline] Selecting the LF switch valid/invalid.

- "n" is valid only in the lowest bit (n0).
- "n" bit means the followings.

| n0 | Condition     |
|----|---------------|
| 0  | LFSW valid.   |
| 1  | LFSW invalid. |

[Caution] When the panel switch is disabled with this command, the LF switch is disabled. Therefore, the paper cannot be fed by operating the LF switch.

[Default] • The initial value of n is "0".

[Sample Program]

```
LPRINT CHR$ (&H1B) + "c5" + CHR$ (0) ; ..... When enabling the LF switch
LPRINT CHR$ (&H1B) + "c5" + CHR$ (1) ; ..... When disabling the LF switch
```

**ESC d n**

[Function] Printing and Feeding the paper by n lines  
 [Code] <1B>H<64>H<n>  
 [Range] \* {0 ≤ n ≤ FF} Data is described in Hex code.  
 [Outline] Prints data inside the buffer and feeds paper by n lines.

- Specified line does not remain.
- The beginning of the line is to be considered as the next printing start position.
- The initial value is not defined.

[Default]

[Sample Program]

```
LPRINT "AAAAA"
LPRINT CHR$ (&H1B) + "d" + CHR$ (2) ;
LPRINT "AAAAA" + CHR$ (&HA) ;
```

[Print Results]

```

A A A A A
      ↑
      ↓ 2/6-inch line feed
A A A A A
```

## ESC i (When Using Auto Cutter)

- [Function] Paper Cut
- [Code] <1B>H<69>H
- [Outline] Activating auto cutter unit (Full cut)
- [Caution]
- This is valid only when n is inputted at the beginning of line.
  - Prior to cutting the paper, feed the paper from the printing position to beyond the paper cutting position of the cutter. Otherwise, the character just after print will remain on this side of the cutter.
  - After having been cut, the paper is delivered out from the Presenter.

[Sample Program]

```
LPRINT "AAAAA" ;
LPRINT CHR$ (&H1B) + "J" ;
LPRINT CHR$ (150) ;
LPRINT CHR$ (&H1B) + "i" ;
LPRINT "AAAAA" ;
LPRINT CHR$ (&H1B) + "J" ;
LPRINT CHR$ (150) ;
LPRINT CHR$ (&H1B) + "i" ;
```

[Print Results]

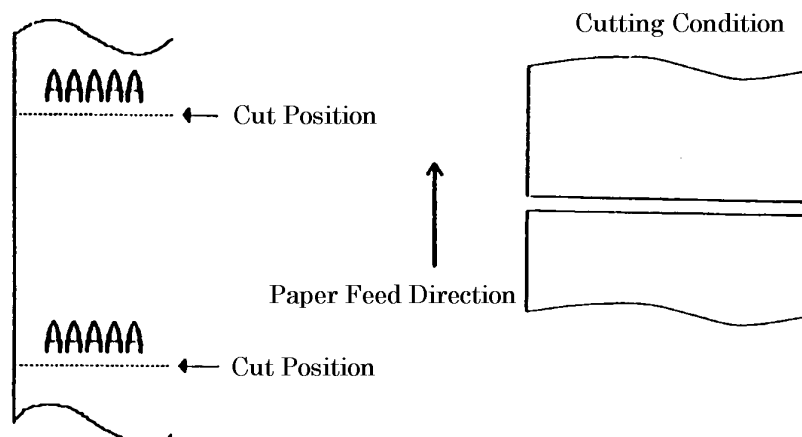

## ESC m (When Using Auto Cutter)

---

|            |                                                                                                  |
|------------|--------------------------------------------------------------------------------------------------|
| [Function] | Paper Cut                                                                                        |
| [Code]     | <1B>H<6D>H                                                                                       |
| [Outline]  | Activating auto cutter unit (Full cut)                                                           |
| [Caution]  | The paper cut commands 'ESC i' and 'ESC m' are the same completely.<br>(See the command 'ESC i') |

---

## ESC t n

---

- [Function]           Selecting Character Code Table
- [Code]                <1B>H<74>H<n>
- [Range]              {0 ≤ n ≤ 1}   Data is described in Hex code.
- [Outline]             Selecting Page n on the character code table:  
The character code table is selected depending on the value of n.  
"n" means the followings.

| n (Hex) | Condition                  |
|---------|----------------------------|
| 0       | Page0(IBM Character #2)    |
| 1       | Page1(Japanese Characters) |

- [Default]            The initial value of n are shown below
- When Japan is selected                : 1(Japanese characters)
  - When non Japan is selected            : 0(IBM characters #2)

[See Also]           Character Code Table

[Sample Program]

```
LPRINT CHR$ (&H1B) + "t" + CHR$ (0) ;
LPRINT " n=0  ";
FOR C=&HB1 TO &HB5
LPRINT CHR$ (C) ;
NEXT C
LPRINT CHR$ (&HA) ;
LPRINT CHR$ (&H1B) + "t" + CHR$ (1) ;
LPRINT " n=1  ";
FOR C=&HB1 TO &HB5
LPRINT CHR$ (C) ;
NEXT C
LPRINT CHR$ (&HA) ;
```

[Print Results]

```
n = 0    ▣▣▣▣▣▣▣▣▣▣ ← Page 0
n = 1    アイエオ ← Page 1
```

## ESC v (Serial Interface Only)

[Function] Transmitting the printer status(Serial Type)

[Code] <1B>H<76>H

[Outline] Current printer status is transmitted..

- [Caution]
- Status sent out consists of 1 byte whose content is as in the table below.
  - In DTR/DSR control, after receptive state of the host (DSR signal being in SPACE state) is confirmed, only 1 byte is transmitted. In XON/XOFF control, DSR signal state not being confirmed, only 1 byte is transmitted.
  - In DTR/DSR control, when the host is in unreceptive state(DSR signal being in MARK state), it waits until receptive state is created.
  - In paper end (paper near end) status, this command may be unreceptive state due to BUSY state.

Remarks. This command is valid only for serial interface model.

| Bit | Function       | Value      |               |
|-----|----------------|------------|---------------|
|     |                | 0          | 1             |
| 0   | Paper near end | with paper | without paper |
| 1   | Not defined    |            |               |
| 2   | Paper end      | With paper | Without paper |
| 3   | Not defined    |            |               |
| 4   | Not used       | Fixed to 0 | —             |
| 5   | Not defined    |            |               |
| 6   | Not defined    |            |               |
| 7   | Not defined    |            |               |

[Sample Program]

```
OPEN "COM1:N81NN" AS #1 ;
PRINT #1, CHR$ (&H1B) + "v" ;
A$ = INPUT$ (1, #1) ;
CLOSE #1
```

# ESC { n

[Function] Specifying/Canceling the Inverted Characters  
 [Code] <1B>H<7B>H<n>  
 [Range] {0 ≤ n ≤ FF} Data is described in Hex code.  
 [Outline] Specifying/canceling inverted characters.

- "n" is valid only for the lowest bit (n0).
- Bit n (n0) means the followings.

| n0 | Condition                       |
|----|---------------------------------|
| 0  | Canceling inverted characters.  |
| 1  | Specifying inverted characters. |

[Caution]
 

- Inverted printing means printing the line at 180°turned.
- This is valid only when this is specified at the beginning of a line.

[Default]
 

- The initial value of n is "0".

[Sample Program]

```
LPRINT CHR$ (&H1B) + "{" + CHR$ (0) ;
LPRINT "AAAAA" + CHR$ (&HA) ;
LPRINT "BBBBB" + CHR$ (&HA) ;
LPRINT CHR$ (&H1B) + "{" + CHR$ (1) ;
LPRINT "AAAAA" + CHR$ (&HA) ;
LPRINT "BBBBB" + CHR$ (&HA) ;
```

[Print Results]

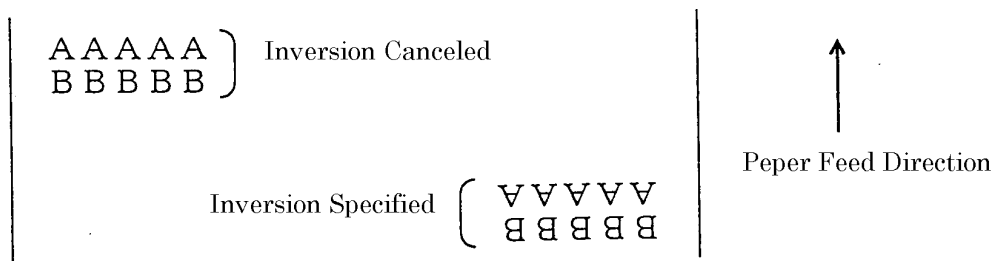

## ESC \$ n1 n2

- [Function] Specifying the Absolute Positions
- [Code] <1B>H<24>H<n1><n2>
- [Range] {0 ≤ n1 ≤ FF}  
{0 ≤ n2 ≤ 1} Data is described in Hex code.
- [Outline] The printing start position is specified in the number of dots (1/203 inch unit) from the beginning of line.
- The number of dots is divided by 256, whose quotient is taken as n2 and the residual as n1.
  - Therefore, the printing start position is equal to n1 + n2 x 256 from the beginning of line..
- [Caution] • Specifying beyond the line end is ignored.
- [Default] • The initial value is not specified.
- [See Also] ESC ¥
- [Sample Program]

```
LPRINT CHR$ (&H1B) + "$" ;
LPRINT CHR$ (0) + CHR$ (0) + "A" ;
LPRINT CHR$ (&H1B) + "$" ;
LPRINT CHR$ (50) + CHR$ (0) + "B" ;
LPRINT CHR$ (&H1B) + "$" ;
LPRINT CHR$ (0) + CHR$ (1) + "C" ;
LPRINT CHR$ (&HA) ;
LPRINT CHR$ (&H1B) + "$" ;
LPRINT CHR$ (100) + CHR$ (0) + "A" ;
LPRINT CHR$ (&H1B) + "¥" ;
LPRINT CHR$ (&HC2) + CHR$ (&HFF) + "B" ;
LPRINT CHR$ (&HA) ;
```

[Print Results]

Absolute Position Specified

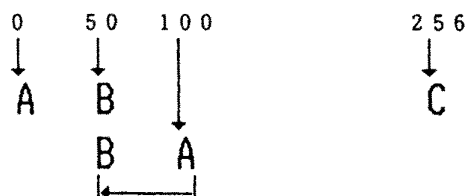

Relative Position Specified – 62

---

**ESC \ n1 n2**

---

|                  |                                                                                                                                                                                                                                                                                                                                                                                                                                                                  |
|------------------|------------------------------------------------------------------------------------------------------------------------------------------------------------------------------------------------------------------------------------------------------------------------------------------------------------------------------------------------------------------------------------------------------------------------------------------------------------------|
| [Function]       | Specifying the Relative Positions                                                                                                                                                                                                                                                                                                                                                                                                                                |
| [Code]           | <1B>H<5C>H<n1><n2>                                                                                                                                                                                                                                                                                                                                                                                                                                               |
| [Range]          | {0 ≤ n1 ≤ FF}<br>{0 ≤ n2 ≤ FF} Data is described in Hex code.                                                                                                                                                                                                                                                                                                                                                                                                    |
| [Outline]        | The printing start position is specified in the number of dots(1/203 inch unit) from the current position. <ul style="list-style-type: none"> <li>• Rightward direction is taken as plus and leftward direction as minus.</li> <li>• To specify N dot in minus (left) direction, use a complement of N for assignment.<br/>-N dots = 65536 - N</li> <li>• The number of dots is divided by 256, whose quotient is taken as n2 and the residual as n1.</li> </ul> |
| [Caution]        | • Specifying exceeding the top of line or the end of line is ignored.                                                                                                                                                                                                                                                                                                                                                                                            |
| [Default]        | • The initial value is not specified.                                                                                                                                                                                                                                                                                                                                                                                                                            |
| [See Also]       | ESC \$                                                                                                                                                                                                                                                                                                                                                                                                                                                           |
| [Sample Program] | [Print Results]                                                                                                                                                                                                                                                                                                                                                                                                                                                  |

See Sample Program and Print Results for ESC \$ on Page 66.

---

**GS S**

---

**(M-type Only)**

|            |                                                                                                                                                                                                                                                                                                                                                                                  |
|------------|----------------------------------------------------------------------------------------------------------------------------------------------------------------------------------------------------------------------------------------------------------------------------------------------------------------------------------------------------------------------------------|
| [Function] | Detecting the Black Mark                                                                                                                                                                                                                                                                                                                                                         |
| [Code]     | <1D>H<53>H                                                                                                                                                                                                                                                                                                                                                                       |
| [Outline]  | The command is valid only when the DS2-5 is set to OFF.<br>When the black mark is valid, inputting the command detects the black mark.<br>When the printer powers on, the black mark is detected and the printing paper is cut and ejected.<br>When an 18-inch black mark cannot be detected, as an alarm, BUSY and FAULT are printed and the printing paper is cut and ejected. |
| [Caution]  | When the DS2-5 is set to ON, the command is disregarded.<br>Even when the command detects the black mark, the printer cuts the printing paper but doesn't eject it.<br>After the alarm, powering the printer on again restores the command.                                                                                                                                      |

---

**GS k n [ d ] k NUL**

---

[Function]            Printing the Bar Code

[Code]                <1D>H<6B>H<n> [ <d> ] k <00>H

[Range]              {0 ≤ n ≤ 7}    Data are described in Hex code.

[Outline]             Specifying a type of bar code and printing bar codes.

- The beginning of line is considered as the next printing start position.
- Depending on the value of n, the following bar code can be selected.

d indicates a character code to be printed and k indicates the number of character to be printed.

| n (Hex) | Bar Code System | Maximum Columns |
|---------|-----------------|-----------------|
| 0       | UPC-A           | ---             |
| 1       | UPC-E           | ---             |
| 2       | JAN13 (EAN)     | ---             |
| 3       | JAN 8 (EAN)     | ---             |
| 4       | CODE 39         | 19              |
| 5       | ITF             | 34              |
| 6       | CODABAR (NW-7)  | 25              |
| 7       | CODE 128        | 23              |

[Caution]            When data being held in the print buffer, this command is ignored.

- Regardless of the specified feed pitch, this command feeds the paper to be required to print a bar code.
- If the character code d cannot be printed in the respective bar code system, the bar code so far will be printed, processing the subsequent data as normal data.
- When a bar code whose number of characters to be printed is fixed has been selected, the number of characters k have to be always made equal to the number of characters to be printed. (The bar code is not printed when not matching.)
- When the horizontal direction exceeds one line length, the excess part is not printed.

[Default]             • The initial value is not specified.

[Description of Bar Codes]    <For print examples, see Page 70.>

UPC-A                This bar code, consisting of numerals only, has a fixed length of 12 column; a 11-columns number entered from the host or application software plus a check column(12th column) automatically calculated inside the printer. If the 12th-column numeral is sent from the host, the entire bar code will be printed as it is.

UPC-E                This bar code, consisting of numerals only, has a fixed length of 8 column; the first number system character is "0" stationary. A 12-column numeral entered from the host or application software is compressed to 8 columns with a check column and printed. The

12th-column check column is automatically calculated inside the printer and sent from the host, the entire bar code will be printed, compressed to 8 columns.

**JAN-13(EAN)** This bar code, consisting of numerals only, has a fixed length of 13 column; a 12-column number entered from the host or application software plus a check column(13th column) automatically calculated inside the printer. If the 13th-column numeral is sent from the host, the entire bar code will be printed as it is.

**JAN-8(EAN)** This bar code, consisting of numerals only, has a fixed length of 8 column; a 7-column number entered from the host or application software plus a check column(8th column) automatically calculated inside the printer. If the 8th-column numeral is sent from the host, the entire bar code will be printed as it is.

**CODE39** This bar code, consisting of uppercase alphabets and numerals, has a variable length of column. A start/stop code "\*" is automatically added by the printer. Available characters include a space and " \$ % + - • / 0 1 2 3 4 5 6 7 8 9 " and uppercase alphabets.

**ITF** This bar code, consisting of numerals only, has a variable length of even column. If an odd-column code is transferred, nothing will be printed.

#### **CODABAR (NW-7)**

This bar code, consisting of alphanumeric, has a variable length of column. Available characters include " 0 1 2 3 4 5 6 7 8 9 A B C D \$ + - • / : " A start/stop code is required; any one of A, B, C, and D is used.

**CODE128**

- This bar code consists of all of 128 ASCII code characters and has a variable length of column. This printer supports the code subsets A, B, and C. By prefixing a transfer code with any one character of A, B, and C, you can select the code subset to start from. If not prefixed with A, B, or C, the code subset B will be selected.
- The code subset A is the bar code consisting of standard uppercase alphabets, numerals, symbols, and special codes.
- The code subset B is the bar code consisting of standard uppercase/lowercase alphabets, numerals, symbols, control codes, and special codes.
- The code subset C is the bar code consisting of special characters and 100 kinds of numbers ranging from 00 to 99.
- The check column automatically calculated inside the printer is added to the end of the entered column to be printed.
- Processing of the special characters  
The characters above the ASCII code number 96 are considered special characters. The following lists the converted characters for entering these characters.

| ASCII Code | Converted Character | Subset Code A | Subset Code B | Subset Code C |
|------------|---------------------|---------------|---------------|---------------|
| 96         | 80h                 | FNC 3         | FNC 3         | -N/A-         |
| 97         | 81h                 | FNC 2         | FNC 2         | -N/A-         |
| 98         | 82h                 | SHIFT         | SHIFT         | -N/A-         |
| 99         | 83h                 | CODE C        | CODE C        | -N/A-         |
| 100        | 84h                 | CODE B        | FNC 4         | CODE B        |
| 101        | 85h                 | FNC 4         | CODE A        | CODE A        |
| 102        | 86h                 | FNC 1         | FNC 1         | FNC 1         |

The following exemplifies a selection of the code subset as a method to utilize the special characters.

<Selection of Code Subset>

- Initial selection: Enter any one character of A, B, and C.
- Conversion on the way: Enter any one character of 82h through 85h

Example) When initially testing with the code subset B, and then, printing the bar code, "123," with the code subset A

- Input code :
- Bar code data : <CODE B>TEST<CODE A>123

[Sample Program]

```
LPRINT CHR$ (&H1D) + "H" + CHR$ (2);
LPRINT CHR$ (&H1D) + "k";
LPRINT CHR$ (4);
LPRINT "123" + CHR$ (0);
```



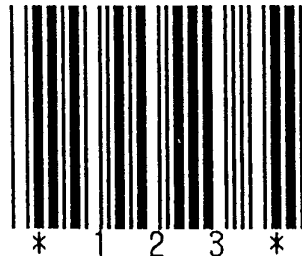



[Print Results]



When the data "123" is printed with the code 39

[Description of Bar Codes]

UPC-A, UPC-E, JAN-13 (EAN), JAN-8 (EAN), CODE39, ITF, CODABAR, CODE128

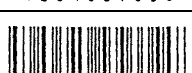
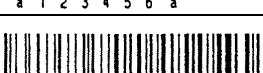
| Type              | Print Sample                                                                        | Outline of Symbol                                                                                                  | Max. column |
|-------------------|-------------------------------------------------------------------------------------|--------------------------------------------------------------------------------------------------------------------|-------------|
| UPC-A             |    | 12-columns fixed-length bar code consisting of numerals only                                                       | –           |
| UPC-E             |    | 8-columns fixed-length bar code consisting of numerals only. Abbreviated version of UPC-A                          | –           |
| JAN-13            |    | 13-columns fixed-length bar code consisting of numerals only                                                       | –           |
| JAN-8             |    | 8-columns fixed-length bar code consisting of numerals only                                                        | –           |
| CODE39            |    | Variable-length bar code consisting of alphabets and numerals. The start/stop code "*" is automatically added.     | 19          |
| ITF               |    | Even-columns variable-length bar code consisting of numerals only                                                  | 34          |
| CODABAR<br>(NW-7) |    | Variable-length bar code consisting of alphanumeric. Any one of A, B, C, and D is required as the start/stop code. | 25          |
| CODE128           |  | Variable-length bar code consisting of all 128 ASCII code characters.                                              | 23          |

Printing is done depending on bar code specification type, number of print column, bar code height, width (Magnification), visible code presence, and bar code data specification.

---

**GS w n**

---

[Function] Selecting the horizontal size(Scale factor) of the Bar Code

[Code] <1D>H <77>H<n>

[Range] {2 ≤ n ≤ 4} Data is described in Hex code.

[Outline] Selecting bar code width.

n denotes the number of dots in fine element width.

[Default] •The initial value of this width is "3".

[Sample Program]

```
LPRINT CHR$ (&H1D) + "h" + CHR$ (30) ;
LPRINT CHR$ (&H1D) + "w" + CHR$ (2) ;
GOSUB BC
LPRINT CHR$ (&H1D) + "h" + CHR$ (50) ;
LPRINT CHR$ (&H1D) + "w" + CHR$ (3) ;
GOSUB BC
LPRINT CHR$ (&H1D) + "h" + CHR$ (80) ;
LPRINT CHR$ (&H1D) + "w" + CHR$ (4) ;
GOSUB BC
END
BC :
LPRINT CHR$ (&H1D) + "k" ;
LPRINT CHR$ (4) ;
LPRINT "12" + CHR$ (0) ;
RETURN
```

[Print Results]

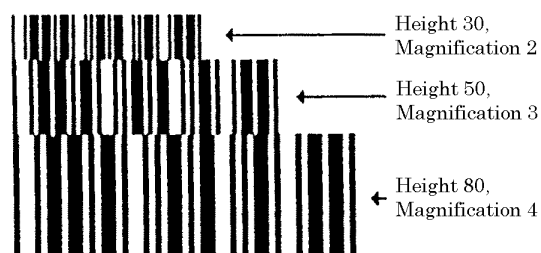

## GS h n

---

|            |                                                                                       |
|------------|---------------------------------------------------------------------------------------|
| [Function] | Selecting the height of the Bar Code                                                  |
| [Code]     | <1D>H<68>H<n>                                                                         |
| [Range]    | {1 ≤ n ≤ FF} Data is described in Hex code.                                           |
| [Outline]  | Selecting bar code height.<br>n denotes the number of dots in the vertical direction. |
| [Default]  | <ul style="list-style-type: none"><li>• The initial value of n is "162".</li></ul>    |

[Sample Program]

[Print Results]

See Sample Program and Print Results for GS w on page 72.

## GS H n

[Function]                 Selecting of Printing Position of HRI Code  
 [Code]                     <1D>H<48>H<n>  
 [Range]                   {0 ≤ n ≤ 3}   Data is described in Hex code.  
 [Outline]                 Selecting printing position of HRI code in printing bar codes.

- "n" means the followings.

| n (Hex) | Printing Position                 |
|---------|-----------------------------------|
| 0       | No printing                       |
| 1       | Above the bar code                |
| 2       | Below the bar code                |
| 3       | Both above and below the bar code |

The HRI code refers to the bar code-turned characters so that you can read them.

[Caution]                 The HRI code is printed in the font selected with GS f.

Specify before the GS k command.

[Default]                 • The initial value of n is "0".

[See Also]                GS f

[Sample Program]

```
LPRINT CHR$ (&H1B) + "3" + CHR$ (5) ;
LPRINT CHR$ (&H1D) + "h" + CHR$ (50) ;
LPRINT CHR$ (&H1D) + "H" + CHR$ (0) ;
GOSUB BC
LPRINT CHR$ (&H1D) + "H" + CHR$ (1) ;
GOSUB BC
LPRINT CHR$ (&H1D) + "H" + CHR$ (2) ;
GOSUB BC
LPRINT CHR$ (&H1D) + "H" + CHR$ (3) ;
GOSUB BC
END
BC :
LPRINT CHR$ (&H1D) + "k" ;
LPRINT CHR$ (4) ;
LPRINT "12" + CHR$ (0) ;
LPRINT CHR$ (&HA) ;
RETURN
```

[Print Results]

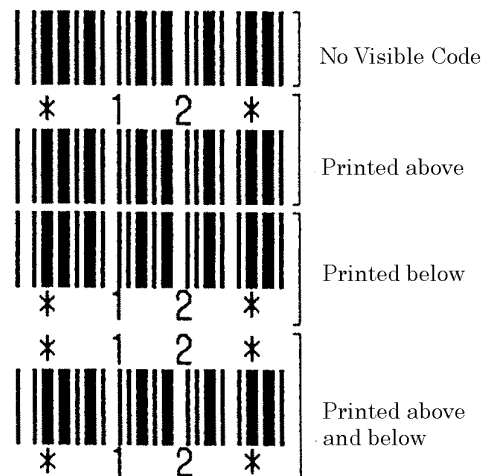

---

## GS f n

---

|            |                                                                                                                       |
|------------|-----------------------------------------------------------------------------------------------------------------------|
| [Function] | Selecting the font of HRI code                                                                                        |
| [Code]     | <1D>H<66>H<n>                                                                                                         |
| [Range]    | n = 0, 1                                                                                                              |
| [Outline]  | Selecting the font of HRI code in printing bar code.<br>The type of font can be printed by selecting n is as follows. |

| n | Font   |
|---|--------|
| 0 | Font A |
| 1 | Font B |

The HRI code refers to the bar code-turned characters so that you can read them.

|                  |                                                                         |
|------------------|-------------------------------------------------------------------------|
| [Caution]        | The HRI code is printed at the position specified with GS h on page 73. |
| [Default]        | The initial value of n is "0".                                          |
| [See Also]       | GS H                                                                    |
| [Sample Program] |                                                                         |

```
LPRINT CHR$ (&H1D) + "h" + CHR$ (50) ;
LPRINT CHR$ (&H1D) + "H" + CHR$ (2) ;
LPRINT CHR$ (&H1D) + "f" + CHR$ (0) ;
GOSUB BC
LPRINT CHR$ (&H1D) + "f" + CHR$ (1) ;
GOSUB BC
END
```

BC :

```
LPRINT CHR$ (&H1D) + "k" ;
LPRINT CHR$ (4) ;
LPRINT "123" + CHR$ (0) ;
LPRINT CHR$ (&HA) ;
RETURN
```

[Print Results]

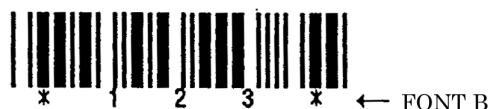
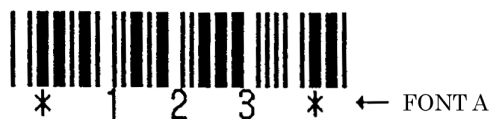

**GS \* n1 n2 [ d ] n1 × n2 × 8**

- [Function] Defining the Download Bit Image
- [Code] <1D>H<2A>H<n1><n2> [ <d> ] n1 × n2 × 8
- [Range] { 1 ≤ n1 ≤ FF }  
 { 1 ≤ n2 ≤ 30 }  
 { n1 × n2 ≤ 51F } Data is described in Hex code.
- [Outline] Defines downloading bit images of the number of dots specified by n1/n2.
- The numbers of dots are n1 x 8 in horizontal direction and n2 x 8 in vertical direction.
  - d indicates bit image data.
  - The download bit image thus defined remains effective until redefinition, ESC @ execution, ESC &, or power OFF takes place.
- [Caution] • A download character and a download bit image can not be defined simultaneously. With this command executed, defined content of a download character is cleared.
- Relations between the bit image data and the dot defined are shown below:
- [See Also] GS /

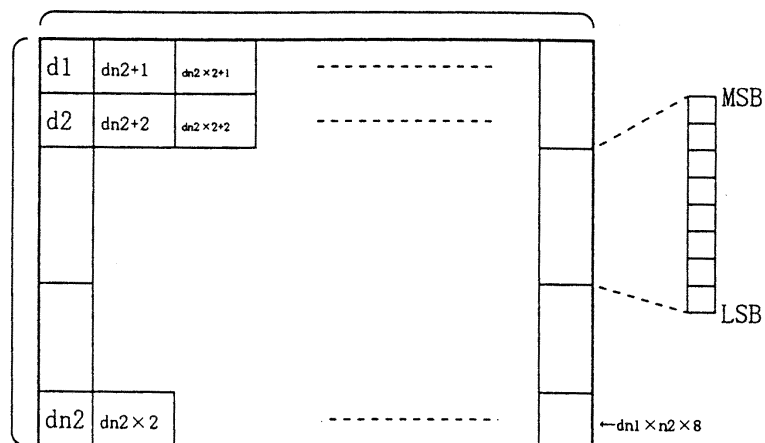

[Sample Program]

```

GOSUB IMG
LPRINT CHR$ (&H1D) + "/" + CHR$ (0) ;
LPRINT CHR$ (&H1D) + "/" + CHR$ (1) ;
LPRINT CHR$ (&H1D) + "/" + CHR$ (2) ;
LPRINT CHR$ (&H1D) + "/" + CHR$ (3) ;
END
IMG :
n 1 = 10 : n 2= 5
LPRINT CHR$ (&H1D) + "*" ;
LPRINT CHR$ (n1) + CHR$ (n2) ;
FOR J=1 TO n1*8
  FOR I=1 TO n2
    LPRINT CHR$ (J) ;
  NEXT I
NEXT J
RETURN
    
```

[Print Results]

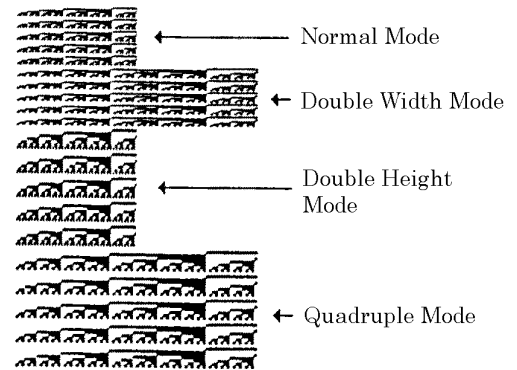

---

**GS / m**

---

[Function]                    Printing the Download, Bit Image

[Code]                        <1D>H<2F>H<m>

[Range]                      {0 ≤ m ≤ 03}    Data is described in Hex code.

[Outline]                     Prints download bit image in a mode specified by m.

- Modes can be selected by m are shown below.

| m | Mode Name                    | Dot Density in Vertical Direction | Dot Density in Horizontal Direction |
|---|------------------------------|-----------------------------------|-------------------------------------|
| 0 | Normal mode                  | 203 DPI                           | 203 DPI                             |
| 1 | Double wide mode             | 203 DPI                           | 101 DPI                             |
| 2 | Double high mode             | 101 DPI                           | 203 DPI                             |
| 3 | Double wide/double high mode | 101 DPI                           | 101 DPI                             |

- [Caution]
- When data exist inside the print buffer, this command is ignored.
  - When a download bit image has not been defined, this command is ignored.
  - A portion of a download bit image exceeding one line length is not printed.
  - A download character and a download bit image cannot be defined simultaneously.

[Default]                     • The initial value is not specified.

[See Also]                    GS \*

[Sample Program]

[Print Results]

See Sample Program and Print Results for GS \* on Page 76.

## GS :

- [Function] Starting / Ending Macro Definition
- [Code] <1D>H<3A>H
- [Outline] Specifying starting / ending macro definition.  
Means termination when received while defining a macro.
- [Caution] Maximum content available for macro definition is 2048 bytes. A portion exceeding 2048 bytes is not defined.
- Even with ESC @ (initialization of the printer) having been executed, defined content is not cleared. Therefore, it is possible to include ESC @ into the content of macro definition.
  - Normal printing operation is carried out even while in macro definition
- [Default] • Initially, Macro is not specified.
- [See Also] GS ^

[Sample Program]

```
LPRINT CHR$ (&H1D) + " : " ;
LPRINT "+----+" + CHR$ (&HA) ;
LPRINT "|      |" + CHR$ (&HA) ;
LPRINT "+----+" + CHR$ (&HA) ;
LPRINT CHR$ (&H1D) + " : " ;
LPRINT CHR$ (&H1D) + " ^ " ;
LPRINT CHR$ (2) + CHR$ (10) ;
LPRINT CHR$ (0) ;
```

[Print Results]

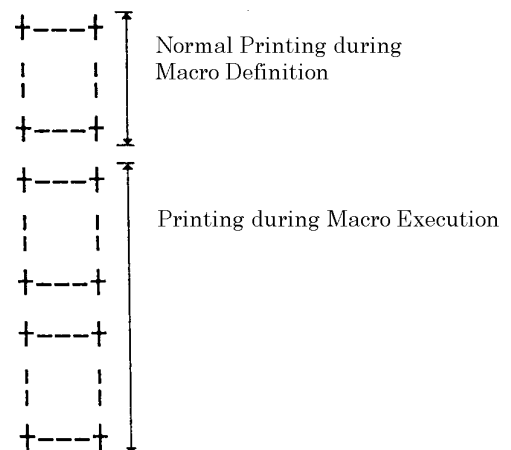

---

## GS ^ n1 n2 n3

---

[Function] Executing the Macro

[Code] <1D>H<5E>H<n1><n2><n3>

[Range] {0 ≤ n1 ≤ FF}  
 {0 ≤ n2 ≤ FF}  
 {0 ≤ n3 ≤ 1} Data is described in Hex code.

[Outline] Executing contents defined in macro.

- "n1~n3" indicate as follows:

n1 : The number of times of macro execution

n2 : Waiting time on macro execution

Waiting time of n2 x 100 msec is given for every execution.

n3 : Macro execution mode

| n3 | Mode                 |
|----|----------------------|
| 0  | Continuous execution |
| 1  | Execution by LFSW    |

Continuous execution: The Macro is executed n1 times continuously at the time intervals specified by n2.

Execution by FEED S: After waiting for lapse of time specified by n2, the ALAME LED flickers and the LF switch is waited to be pressed. When it is pressed, the macro is executed once. This action is repeated n1 times.

- [Caution]
- When this command is received while in macro definition, suspension of macro definition is indicated. At this time, the defined content is cleared.
  - No execution takes place when macro is held undefined or n1=0.
  - While in macro execution with n3=1, paper feed with the LF SW is not available.

[Default] • Initially, this command is not specified.

[See Also] GS :

[Sample Program]

[Print Results]

See Sample Program and Print Results for GS : on Page 79.

## 11. CHARACTER CODES TABLE

### 11.1 International (Page 0)

|   |     |     |    |   |   |   |   |   |   |   |   |   |   |   |   |    |
|---|-----|-----|----|---|---|---|---|---|---|---|---|---|---|---|---|----|
|   | 0   | 1   | 2  | 3 | 4 | 5 | 6 | 7 | 8 | 9 | A | B | C | D | E | F  |
| 0 | NUL |     | SP | 0 | @ | P | . | p | Ç | E | á | ☐ | L | ⊥ | ∞ | ≡  |
| 1 |     | ION | !  | 1 | A | Q | a | q | ü | æ | í | ☐ | ⊥ | ⊥ | β | ±  |
| 2 |     |     | "  | 2 | B | R | b | r | é | Æ | ó | ☐ | ⊥ | ⊥ | Γ | ≈  |
| 3 |     | XOF | #  | 3 | C | S | c | s | á | ô | ú |   | ⊥ | ⊥ | π | ≡  |
| 4 |     |     | \$ | 4 | D | T | d | t | à | ö | ñ | ⊥ | ⊥ | ⊥ | Σ |    |
| 5 |     |     | %  | 5 | E | U | e | u | à | ò | Ñ | ⊥ | ⊥ | ⊥ | σ |    |
| 6 |     |     | &  | 6 | F | V | f | v | á | û | à | ⊥ | ⊥ | ⊥ | μ | ÷  |
| 7 |     |     | '  | 7 | G | W | g | w | ç | ù | ō | ⊥ | ⊥ | ⊥ | τ | ≈  |
| 8 |     |     | (  | 8 | H | X | h | x | é | ÿ | ó | ⊥ | ⊥ | ⊥ | Φ | o  |
| 9 | HT  |     | )  | 9 | I | Y | i | y | ë | 0 | ⊥ | ⊥ | ⊥ | ⊥ | θ | .  |
| A | LF  |     | *  | : | J | Z | j | z | è | ü | ⊥ |   | ⊥ | ⊥ | Ω | .  |
| B |     | ESC | +  | ; | K | [ | k | { | ï | ø | ½ | ⊥ | ⊥ | ■ | δ | √  |
| C |     | FS  | ,  | < | L | \ | l |   | í | £ | ¼ | ⊥ | ⊥ | ▬ | ∞ | n  |
| D |     | GS  | -  | = | M | ] | m | } | ì | ¥ | í | ⊥ | ⊥ | ▬ | φ | 2  |
| E |     |     | .  | > | N | ^ | n | ~ | ã | ℞ | « | ⊥ | ⊥ | ▬ | ε | ■  |
| F |     |     | /  | ? | O | _ | o | € | À | ƒ | » | ⊥ | ⊥ | ▬ | ∩ | SP |



### 11.3 International Character Code Table

|    | 国名         | 23 | 24 | 40 | 5B | 5C | 5D | 5E | 60 | 7B | 7C | 7D | 7E |
|----|------------|----|----|----|----|----|----|----|----|----|----|----|----|
| 0  | U.S.A.     | #  | \$ | @  | [  | \  | ]  | ^  | `  | {  |    | }  | ~  |
| 1  | France     | #  | \$ | a  | ·  | ç  | §  | ^  | `  | é  | ù  | è  | ¨  |
| 2  | Germany    | #  | \$ | §  | λ  | ö  | ü  | ^  | `  | a  | o  | u  | ü  |
| 3  | U.K.       | £  | \$ | @  | [  | \  | ]  | ^  | `  | {  |    | }  | ~  |
| 4  | Denmark I  | #  | \$ | @  | Æ  | Ø  | Λ  | ^  | `  | æ  | ø  | á  | ~  |
| 5  | Sweden     | #  | ☒  | é  | λ  | ö  | λ  | ü  | é  | a  | o  | á  | ü  |
| 6  | Italy      | #  | \$ | @  | ·  | \  | é  | ^  | ù  | a  | ò  | è  | ì  |
| 7  | Spain      | ₧  | \$ | @  | i  | ñ  | ¿  | ^  | `  | ¨  | n  | }  | ~  |
| 8  | Japan      | #  | \$ | @  | [  | ¥  | ]  | ^  | `  | {  |    | }  | ~  |
| 9  | Norway     | #  | ☒  | é  | Æ  | Ø  | Λ  | ü  | é  | æ  | ø  | á  | ü  |
| 10 | Denmark II | #  | \$ | é  | Æ  | Ø  | Λ  | ü  | é  | æ  | ø  | á  | ü  |

## APPENDIX 1. BLOCK DIAGRAM

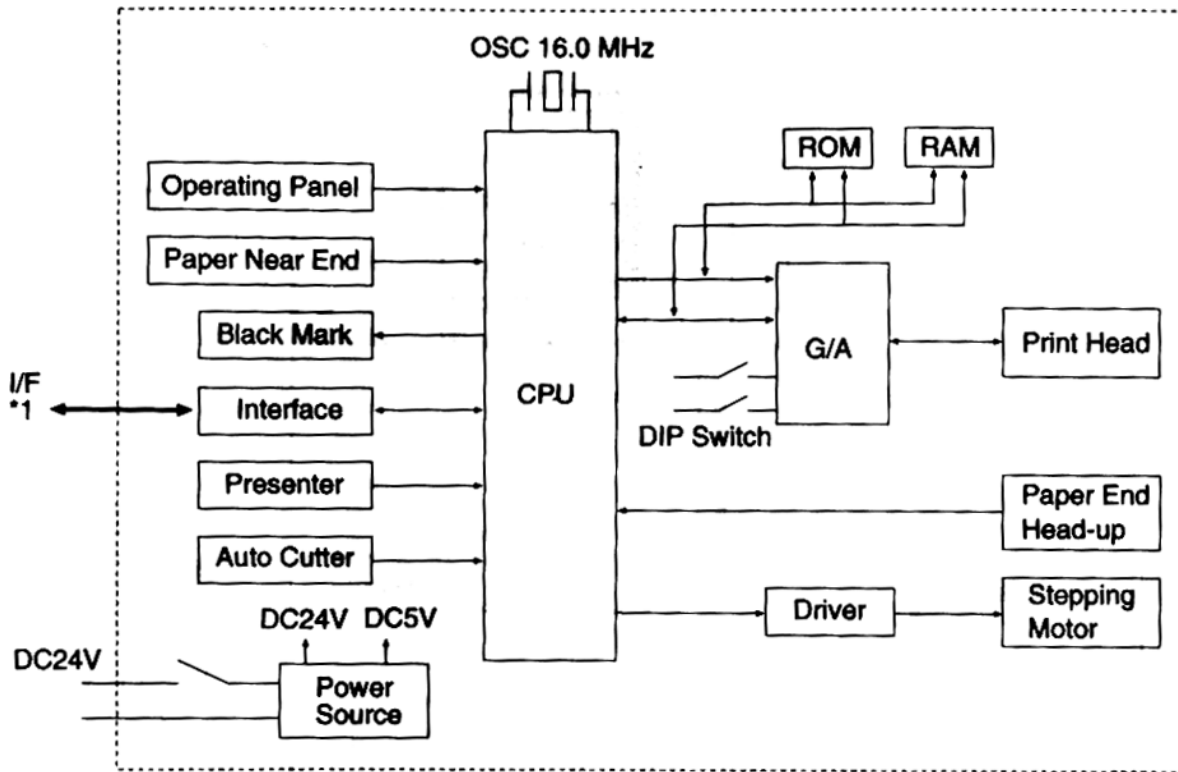

- \*1 Parallel Interface --- Centronics compliant
- Serial Interface --- RS-232C compliant

## APPENDIX 2. OUTLINE DRAWING FOR PPU

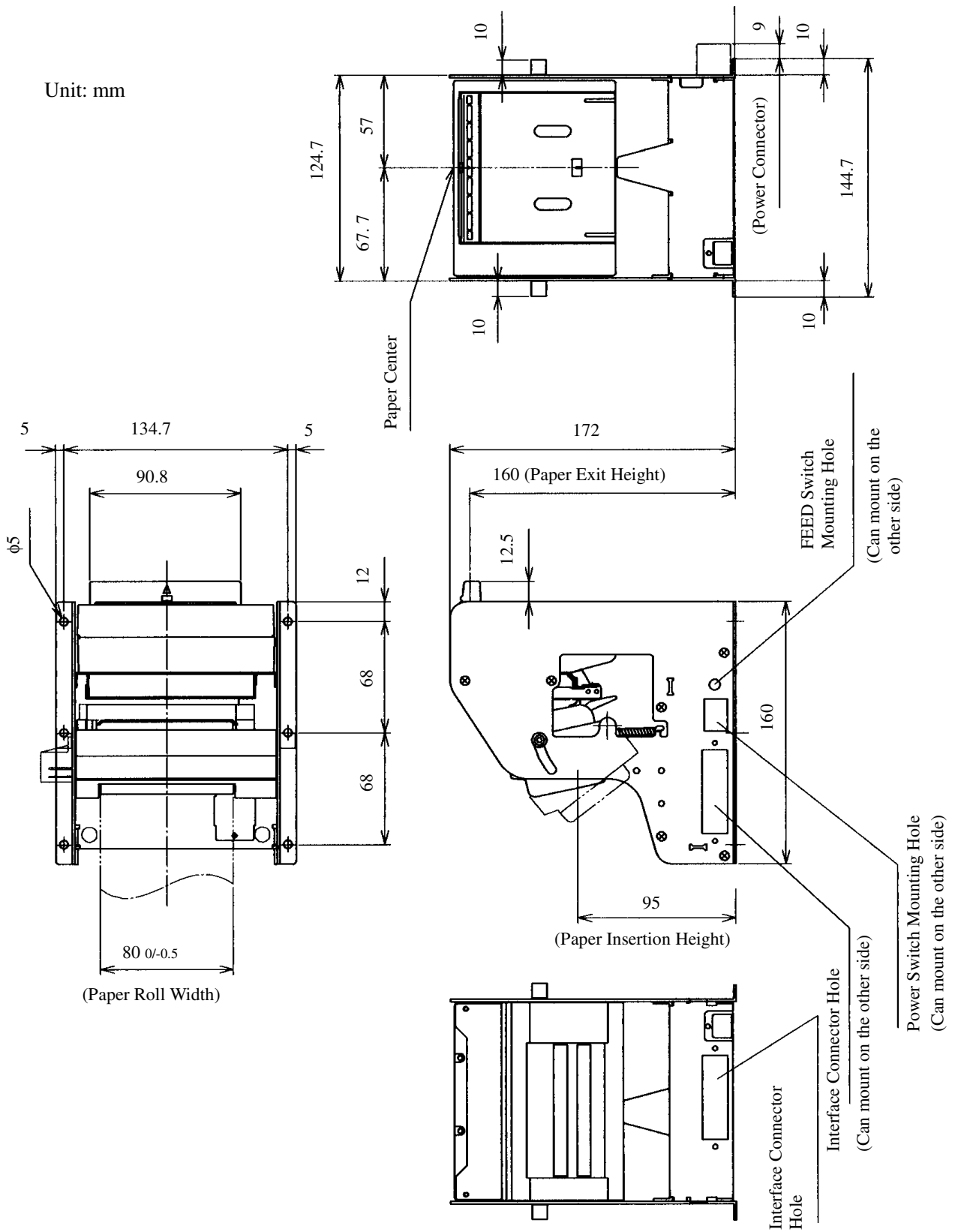

**APPENDIX 3. OUTLINE DRAWING FOR PHU**

Unit: mm

