

CITIZEN

Specifications

PRINTER PRESENTER UNIT
MODEL PRU-PMU-PHU Series

Rev.1.0 First created Oct. 14, 1999

Rev.1.1 Revised Jan. 25, 2000

Japan CBM Corporation

THE TABLE OF CONTENTS

1. GENERAL OUTLINE	1
1.1 Features	1
1.2 Uses	1
2. BASIC SPECIFICATIONS	3
2.1 Classification of Equipment	3
2.1.1 PRU Series (Presenter Unit)	3
2.1.2 PMU Series (Printer Mechanism Unit)	3
2.1.3 PHU Series (Paper Holding Unit)	3
2.2 Specifications Lists	4
2.2.1 PRU Series (Presenter Unit)	4
2.2.2 PMU Series (Printer Mechanism Unit)	7
2.2.3 PHU Series (Paper Holding Unit)	7
2.3 Designing PRU and PMU Unit Installation	8
3. CONNECTION TERMINALS	10
3.1 Connection Terminals	10
3.1.1 Presenter's Connection Terminals	10
3.1.2 Auto-Cutter's Connection Terminals	11
3.2 PMU Connection Terminals	12
4. FLOW CHART	15
4.1 PRU Unit Initialization at Power On	15
4.2 Printing (Issuing Receipts)	17
4.3 Outputting Printed Paper	18
5. TIMING CHART	19
5.1 PRU Timing Chart	19
5.2 PPU Timing Chart (Controlled by paper sensor)	20
6. DESIGN CONSIDERATIONS	21

7. OPERATION	22
7.1 PRU (Presenter Unit)	22
7.1.1 Clearing Jams in the Presenter	22
7.1.2 Releasing a Locked Cutter	23
7.2 PMU (Printer Mechanism Unit)	24
7.2.1 Loading Printing Paper	24
7.2.2 Removing Residual Paper	26
7.2.3 Clearing Paper Jams	27
7.3 PHU (Paper Holding Unit)	28
7.3.1 Loading a Paper Roll	28
7.3.2 Paper-Near-End Sensor Function	29
8. OUTLINE DRAWINGS	30
8.1 Outline Drawing for PRU-130	30
8.2 Outline Drawing for PMU-231	31
8.3 Outline Drawing for PHU-131/132	32

1. GENERAL OUTLINE

The PRU-130 is a presenter unit (automatic paper feed output unit) equipped with an auto-cutter mechanism. When used in conjunction with various types of printer, the PRU-130 can help to prevent paper misfeeds, paper jams, and troubles associated with issuing coupons and receipts. The PMU-231 is a mechanical printer unit exclusively designed for the PRU-130. The PHU-131 / 132 is a paper holder that can accommodate a large-diameter paper roll.

1.1 Features

<PRU-130>

- Compact and lightweight.
- High reliability realized at a low cost, based on a simple mechanism.
- Up to 170 mm (or 6.7 inches) long receipts can be issued. (Receipts longer than 170 mm are pushed out of the paper output slot as printing proceeds.)
- Equipped with a thin-type, high-reliability auto-cutter.

<PMU-231>

- High speed with low noise, based on line thermal printing technology.
- Long-life head adopted, and high reliability attained with a simple mechanism.

<PHU-131 / 132>

- Capable of holding a large-diameter paper roll (ø 203 mm max.).
- Near-paper-end sensor adjustable.
- Capable of 2-level detection of near-paper-end conditions. (PHU-132)

1.2 Uses

- Issuing a variety of tickets and coupons (game machines and amusement equipment).
- Unattended ticket issuing systems
- Outdoor information terminals (KIOSK)
- ATM bank terminals

CAUTION:

- Install this equipment to machines which are placed horizontally and securely.
- Do not install the equipment near a heater, radiator, or in direct sunlight.
- Avoid using the equipment in a high-temperature, high-humidity, or dirty environment.
- Avoid condensation occurring on or inside the equipment. If condensation should occur, never turn on the equipment until the condensation disappears completely.
- Be sure to keep this User's Manual with care for future reference.

2. BASIC SPECIFICATIONS

2.1 Classification of Equipment

2.1.1 PRU Series (Presenter Unit)

PRU-130

<Composition>

- Paper transport section
- Auto-cutter
- Paper sensor
- Attaching bracket

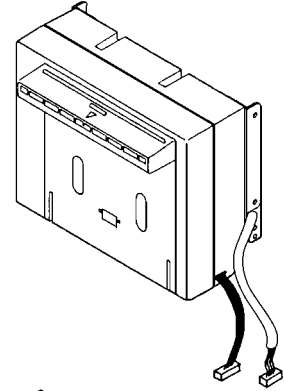

2.1.2 PMU Series (Printer Mechanism Unit)

PMU-231

<Composition>

- Printer mechanism
- Paper guide
- Attaching bracket

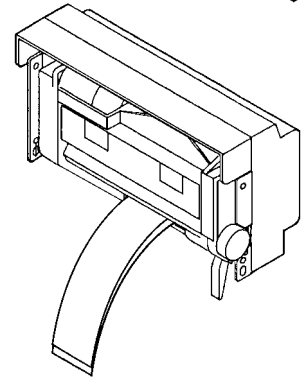

2.1.3 PHU Series (Paper Holding Unit)

PHU-13 1

- PNE sensor
- 1 : 1 piece
- 2 : 2 pieces

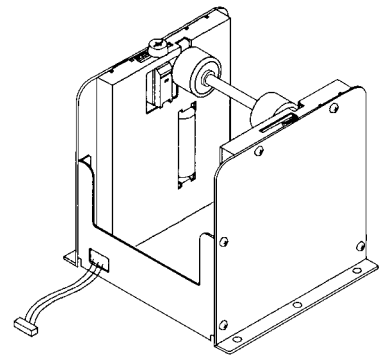

2.2 Specifications Lists

2.2.1 PRU Series (Presenter Unit)

(1) General Specifications

Item	Content
Used Paper	Type : Thermal paper Paper width : 58 to 82.5 mm Paper thickness : 60 to 85 μ m
Presenter	Standard issue length : 64 to 170 mm (2.5 to 6.7 inches) When used in combination with the PMU-231 *Refer to "2.3 Designing PRU and PMU Unit Installation" Issue speed : Approx. 350 mm/sec
Auto-cutter (ACS-230F)	Cutting method : V-shaped blade, slide-type full cutting Allowable cutting frequency : 20 cuts/min
Drive voltage	DC 24 V \pm 10% (Motor) DC 5 V \pm 5% (Sensor related)
Reliability	Presenter life: 30 km or over Auto cutter life : 500,000 cuts or over
Use environment	Operation : 5 to 40 C°; 35 to 85 % RH (no condensation) Storage : - 20 to 60 C°; 10 to 90 % RH (no condensation)
External dimensions	Refer to "8.1 Outline Drawing for PRU-130".
Weight	0.5 kg

(2) Paper issue length

64 to 170 mm (2.5 to 6.7 inches)

- When used in combination with the printer mechanism unit PMU-231.
- The length of paper longer than 170 mm is pushed out of the paper output slot.
- Refer to "2.3 Designing PRU and PMU Unit Installation" and "4. FLOW CHART" and "5. TIMING CHART".

(3) Motor

When voltage is applied to the motor, the paper is transported. Referring to "4. FLOW CHART" and "5. TIMING CHART", perform motor control.

Type : DC brush motor
Drive voltage : DC 24 V \pm 10 %
Current : Max. starting current : 140 mA (DC 24 V, 25 C°)
Ave. starting current : 60 mA (DC 24 V, 25 C°)

• Recommended circuit diagram

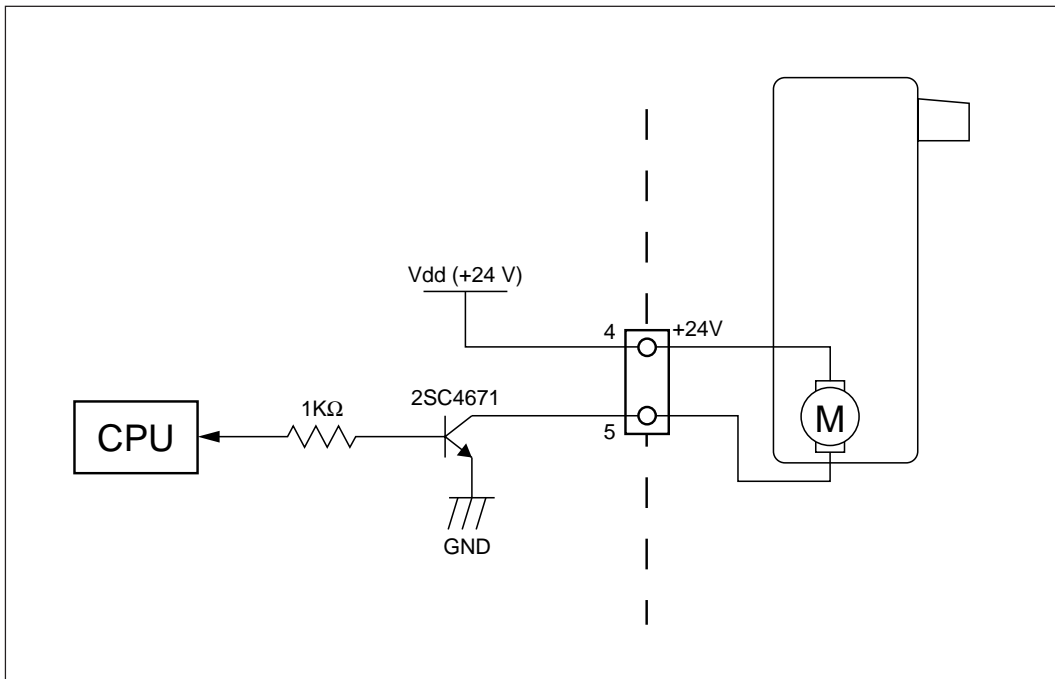

* 2SC4671 is a Darlington transistor with a built-in Zener diode.
 * For pin numbers, refer to “ 3. 1 Connection Terminals”.

(4) Paper sensor

- Type : Reflective-type photo-interrupter
- Product No. : GP2S24 (SHARP)
- Absolute max. rating : (25 C°)

	Item	Symbol	Rated value
Input	Forward current	I_F	50 mA
	Reverse current	V_R	6 V
	Allowable loss	P	75 mW
Output	Collector-emitter voltage	V_{CEO}	35 V
	Emitter-collector voltage	V_{ECO}	6 V
	Collector current	I_C	20 mA
	Collector loss	P_C	75 mW
Total allowable loss		P_{tot}	100 mA
Operating temperature		T_{opr}	- 20 to +85 C°
Storage temperature		T_{stg}	- 40 to +100 C°
Soldering temperature (within 5 sec)		T_{sol}	260 C°

• Photoelectric characteristics

Item		Symbol	Condition	Min. value	Standard value	Max. value	Unit	
Input	Forward voltage	V_F	$I_F=20\text{ mA}$	—	1.2	1.4	V	
	Reverse current	I_R	$V_R=6\text{ V}$	—	—	10	μA	
Output	Dark current	I_{CEO}	$V_{CE}=20\text{ V}$	—	10^{-9}	10^{-7}	A	
Transfer characteristics	Photocurrent		I_C	$I_F=4\text{ mA}, V_{CE}=2\text{ V}$	20	45	120	μA
	Response time	Upper limit	t_r	$V_{CE}=2\text{ V}, I_C=100\text{ }\mu\text{A}$	—	20	100	μs
		Lower limit	t_f	$R_L=1\text{ k}\Omega, d=1\text{ mm}$	—	20	100	μs
	Leakage current		I_{LEAK}	$I_F=4\text{ mA}, V_{CE}=2\text{ V}$	—	—	0.1	μA

• Recommended circuit diagram

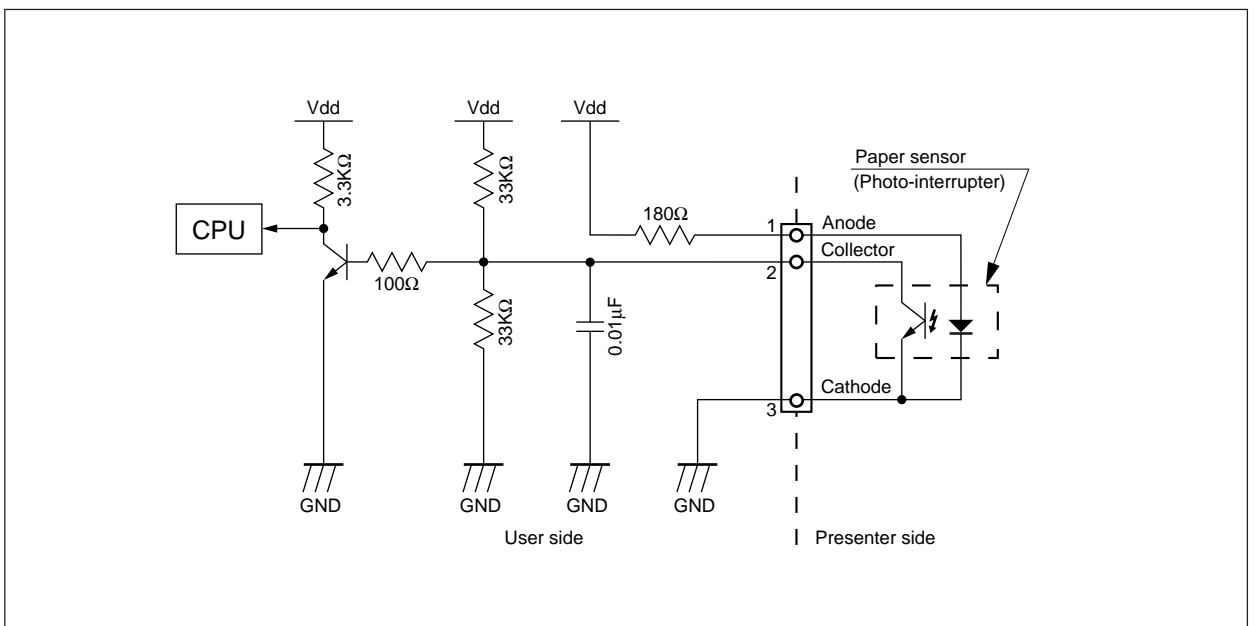

* For pin numbers, refer to “ 3. 1 Connection Terminals”.

(5) Auto Cutter

For recommend circuit and sequence diagrams, refer to the separate “ACS 230 Specifications”.

2.2.2 PMU Series (Printer Mechanism Unit)

<General Specifications>

Item	Content
Print mechanism	LT-380V Bottom paper insertion
Print method	Line thermal dot printing
Print width	72 mm/576 dots
Dot density	8 dots/mm (horizontal and vertical)
Print speed	62.5 mm/s (at max. speed), (500 dot lines/s)
Print column and character size	48 columns (12 × 24 font A) 1.25 × 3.00 mm 64 columns (9 × 24 font B) 0.88 × 3.00 mm
Line spacing	4.23 mm (1/6 inches) Selectable with commands (1/203 inches min.)
Types of bar code	UPC-A, JAN (EAN) : 13 col./8 col., ITF, CODE39, CODE128, CODABAR
Used Paper	Thermal paper roll : Width 80 mm Paper thickness : 60 to 85 μm Recommended paper : TF-50KS-E, E2C (Nippon Paper)
Sensor	Auto Loading detection Black mark detection (optional) Head temperature detection, Head-up detection
Supply voltage	DC 24 V ± 7 %
Power consumption	100 W
Weight	0.3 kg
External dimensions	Refer to “8.2 Outline Drawing for PMU-231”.
Operating temperature and relative humidity	5 to 40 °C; 35 to 85 % RH (no condensation)
Storage temperature and relative humidity	-20 to 60 °C; 10 to 90 % RH (no condensation)
Reliability	Print head service life Pulse resistance : 50 million pulses or over (print coverage 12.5 %) Wear resistance : 30 km or over (at normal temperature and humidity with recommended thermal paper)

* For details, refer to the specifications for the LT-380/381 Thermal Printers.

2.2.3 PHU Series (Paper Holding Unit)

<General Specifications>

Item	Content
Paper	Paper rolls Width 80 mm Outside diameter ø 203 mm or less Inside diameter ø 25.4 mm Paper thickness 60 to 85 μm
Sensor	PHU-131 PaperNearend sensor 1-level (adjustable)
	PHU-132 PaperNearend sensor 2-level (adjustable)
Weight	0.9 kg (with paper roll excluded)
External dimensions	Refer to “8.3 Outline Drawing for PHU-131/132”.
Operating temperature and humidity	5 to 40 °C; 35 to 85 % RH (no condensation)
Storage temperature and humidity	-20 to 60 °C; 10 to 90 % RH (no condensation)

2.3 Designing PRU and PMU Unit Installation

Install the PRU and PMU units by referring to the following dimensions.

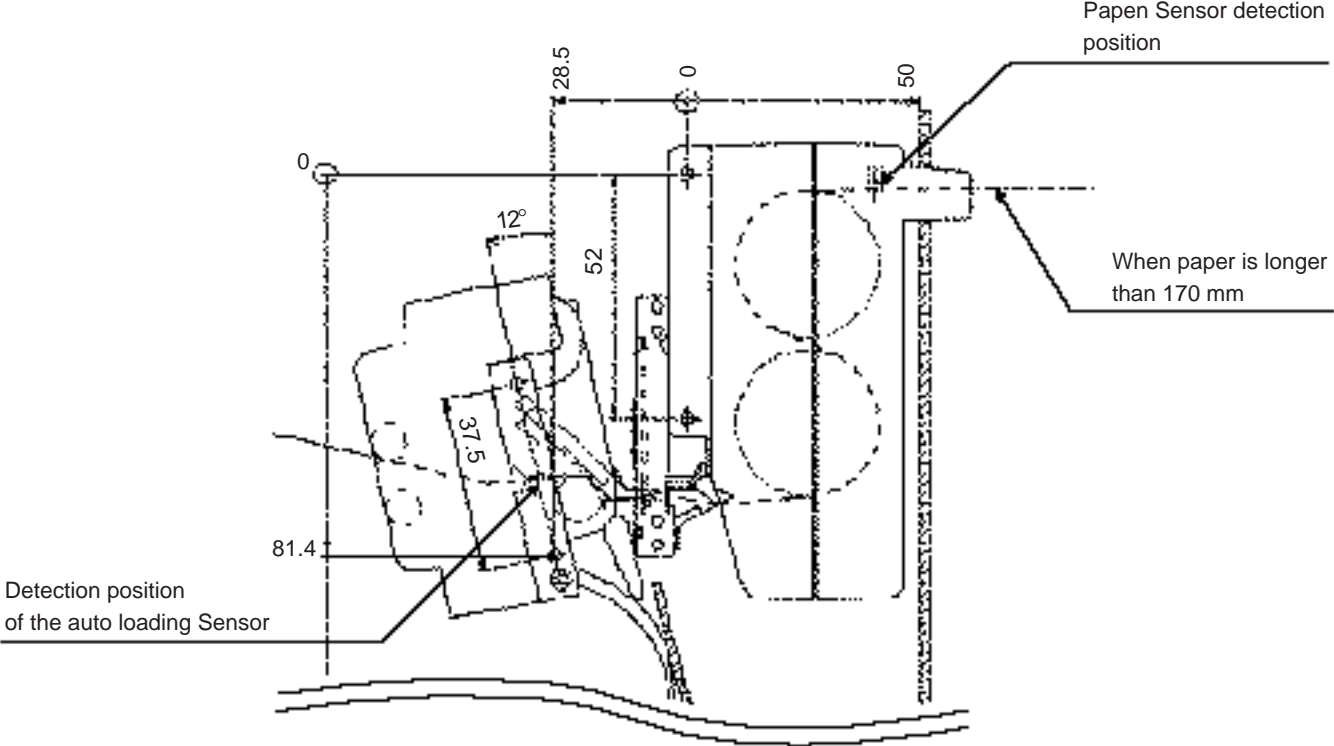

CAUTION:

- As mounting holes for the PRU and PMU units, \varnothing 2.7 mm burred holes are provided. So, when mounting them, use M3 tapping screws.
- Exercise good care so that no unnecessary load is applied to the equipment and cables.
- Make sure that there are no obstructing objects when opening/closing the PRU front door.
- Avoid installing the equipment in a hot and/or humid place.
- Avoid installing the equipment in a dusty place or where it is subjected to vibrations.

3. CONNECTION TERMINALS

3.1 Connection Terminals

3.1.1 Presenter's Connection Terminals

(1) Connectors Used and their purposes

Function	No. of pins	Type	Recommended mating connector
Drive motor	5	Molex 51004-0500	Molex 53014-0510
Paper sensor			53015-0510
			53025-0510

(2) Pin layout

Terminal No.	Terminal name	Function
1	Light-emitting diode Anode	Paper sensor
2	Photo-transistor Collector	
3	Photo-transistor Emitter	
4	\bar{A}	Presenter drive motor
5	A	

(3) Circuit Diagram

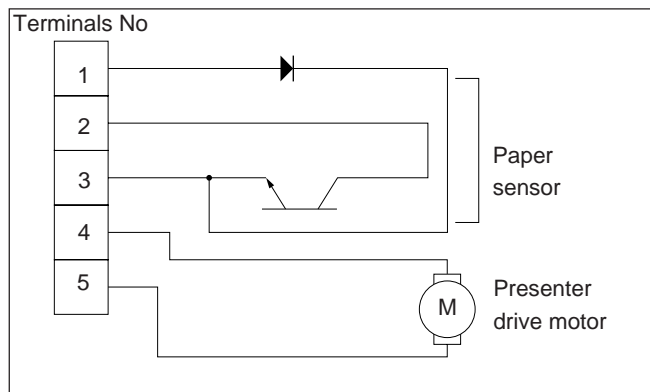

(4) Terminal layout and color

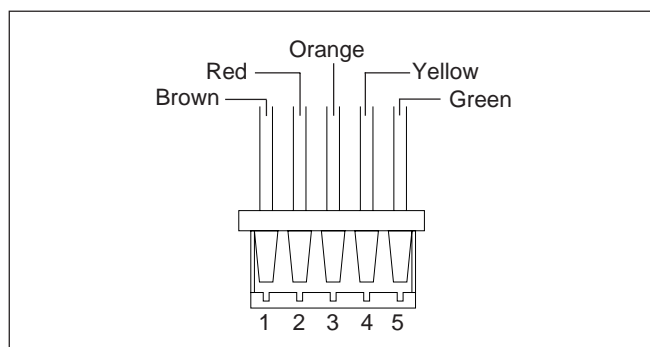

3.1.2 Auto-Cutter's Connection Terminals

(1) Connectors Used and their purposes

Function	No. of pins	Type	Recommended mating connector
Cutter drive motor Switch	4	Molex 5264-04	Molex 5267 5268

(2) Pin layout

Terminal No.	Wire color	Function
1	Red	Motor (+)
2	Black	Motor (-)
3	Gray	Switch
4	Gray	Switch

(3) Terminal layout and color

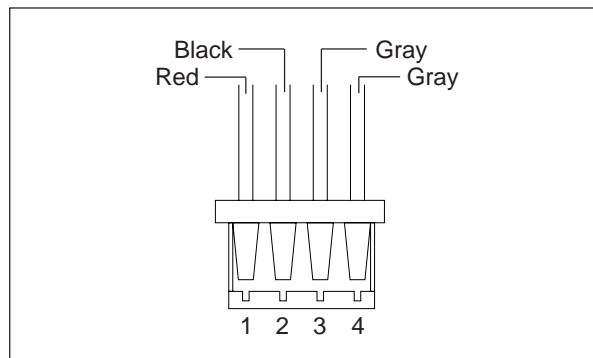

3.2 PMU Connection Terminals

The connection terminals are comprised of two flexible flat cables (FFC), the details of which are shown below.

(1) Cable Connectors used and their purposes

Function	No. of pins	Type	Recommended mating connector
<ul style="list-style-type: none"> •Motor •Paper sensor •Head-up sensor •Thermal head 	20	FFC (Pitch = 1.25 mm)	Molex 5597-20APB 5597-20CPB

(2) Arrangement of FCC cable terminals

The arrangement of the FFC terminals and the functions of their terminal pins are as shown below.

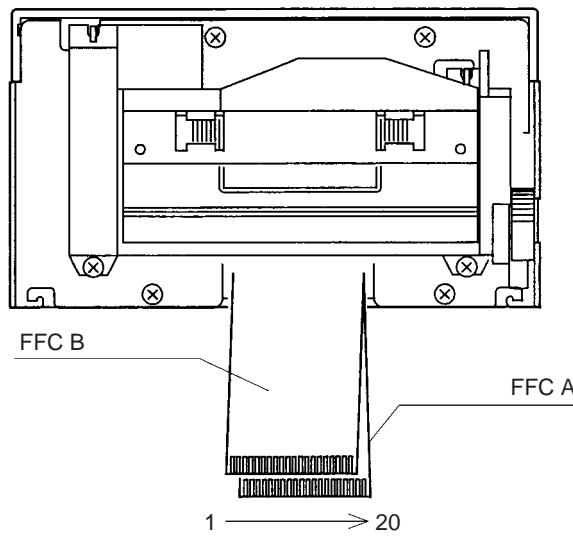

(3) The functions of the FFC terminals pins

<FFC A>

Terminal No.	Signal name	Function
1	STRB 3	Strobe 3
2	STRB 2	Strobe 2
3	STRB 2	Strobe 2
4	STRB 2	Strobe 2
5	STRB 1	Strobe 1
6	STRB 1	Strobe 1
7	STRB 1	Strobe 1
8	V cc	Thermal head driver power supply
9	TH	Thermistor
10	GND	GND
11	CP	Clock signal for data transfer
12	DO	Print data serial output
13	PR	For identification of heating element resistance
14	GND	GND
15	GND	GND
16	GND	GND
17	GND	GND
18	COM	Thermal head common
19	COM	Thermal head common
20	COM	Thermal head common

<FFC B>

Terminal No.	Signal name	Function
1	A	Paper feed motor
2	B	
3	A	
4	B	
5	Photo-transistor collector	Paper sensor
6	Photo-transistor emitter	
7	Light-emitting diode anode	
8	Light-emitting diode cathode	
9	Head-up sensor output	Head-up sensor
10	Head-up sensor output	
11	COM	Thermal head common
12	COM	Thermal head common
13	COM	Thermal head common
14	GND	GND
15	GND	GND
16	GND	GND
17	LATCH	Print data latch signal
18	DI	Print data serial input
19	STRB 3	Strobe 3
20	STRB 3	Strobe 3

4. FLOW CHART

4.1 PRU Unit Initialization at Power On

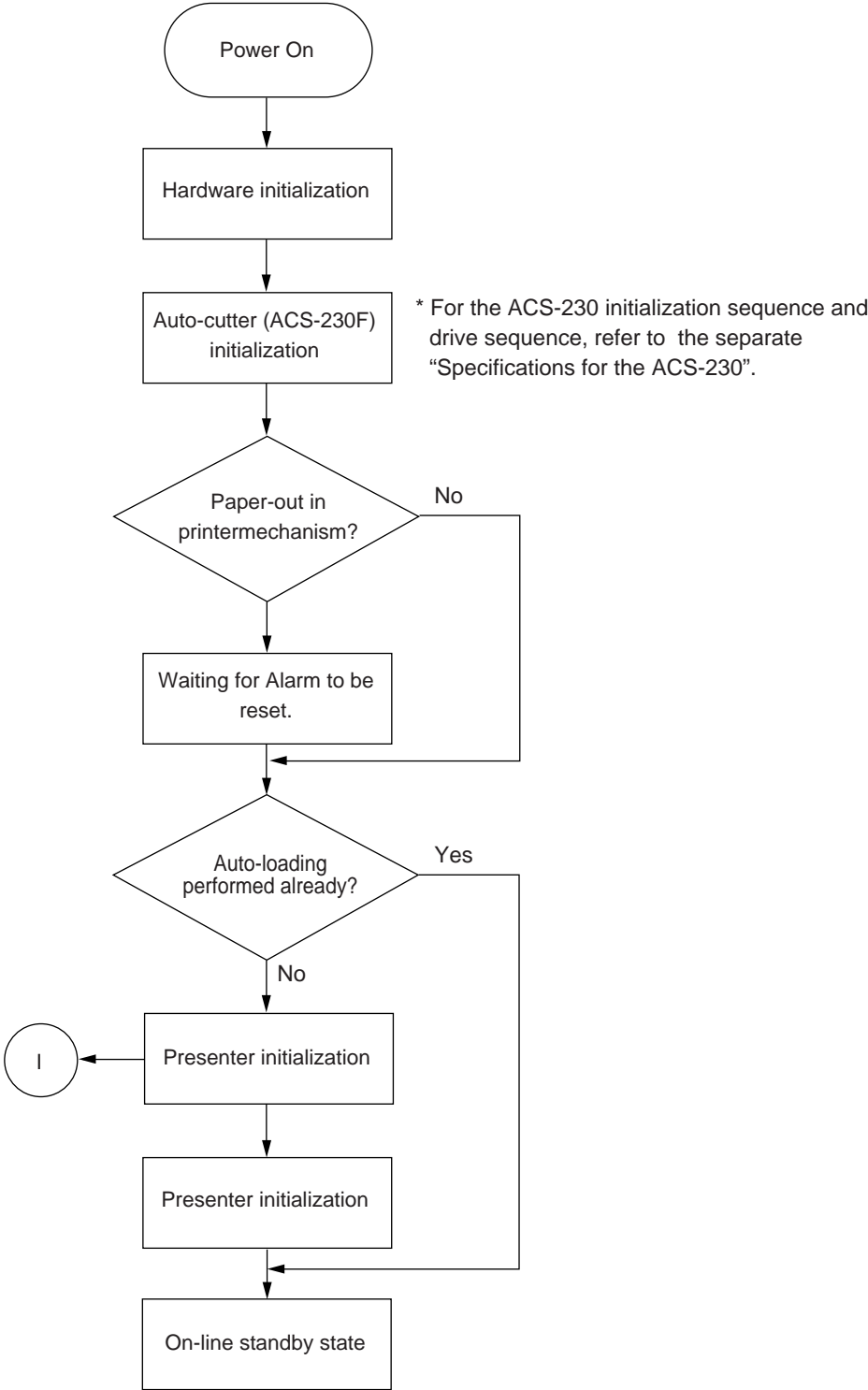

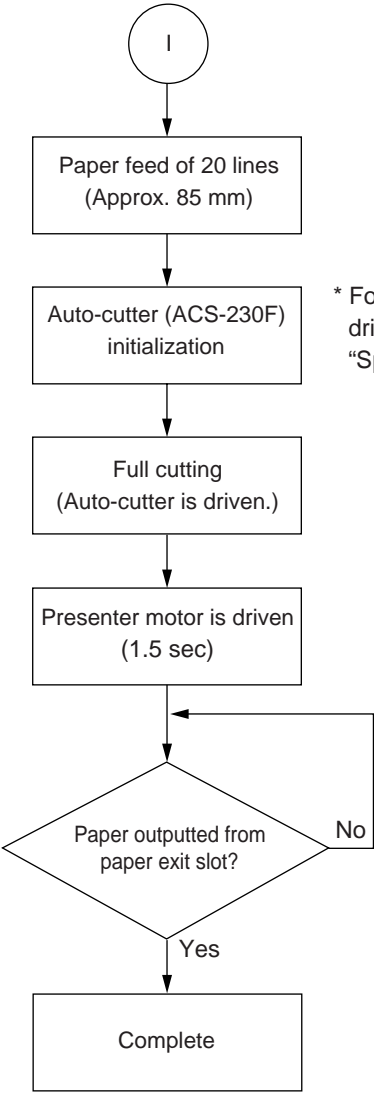

* For the ACS-230 initialization sequence and drive sequence, refer to the separate "Specifications for the ACS-230".

4.2 Printing (Issuing Receipts)

The following sequence takes place when one of various print commands, such as print command (OAh), print and line feed command (ODh), print and minimal-pitch paper feed command (ESC J), and print and n-line paper feed command (ESC d), is executed.

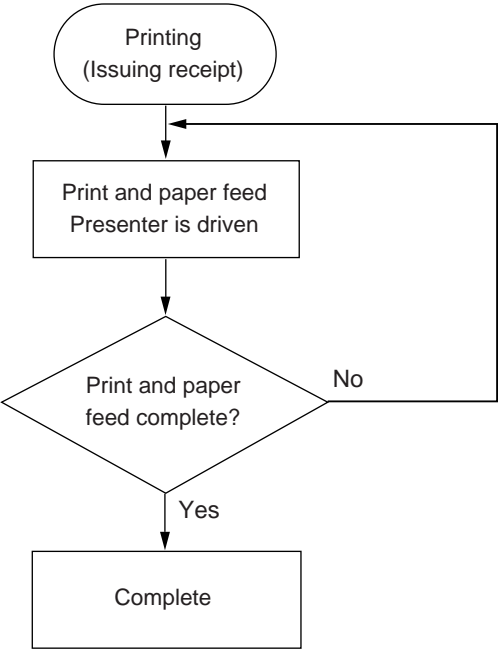

4.3 Outputting Printed Paper

The following sequence takes place in synchronism with the driving of the auto-cutter.

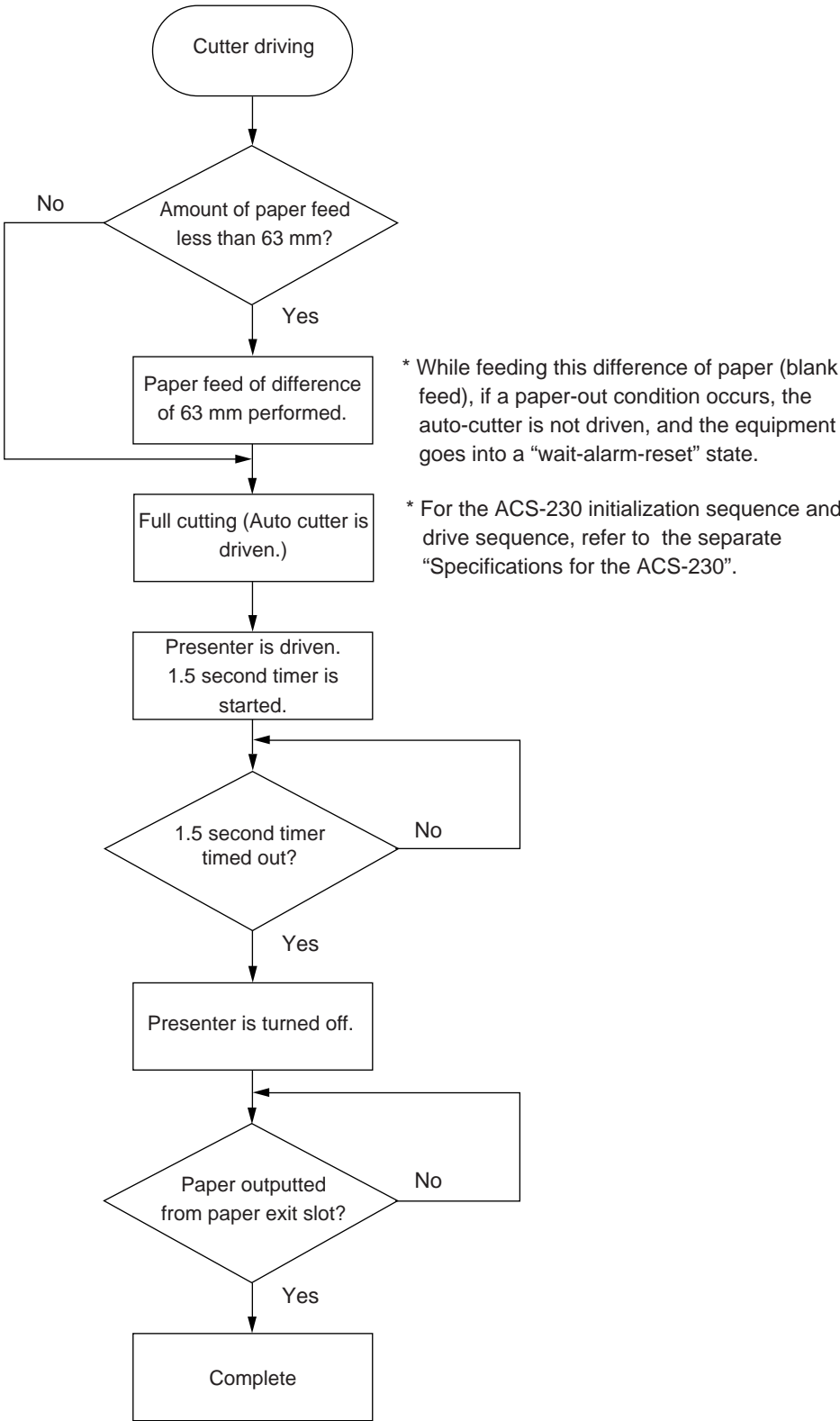

5. TIMING CHART

5.1 PRU Timing Chart

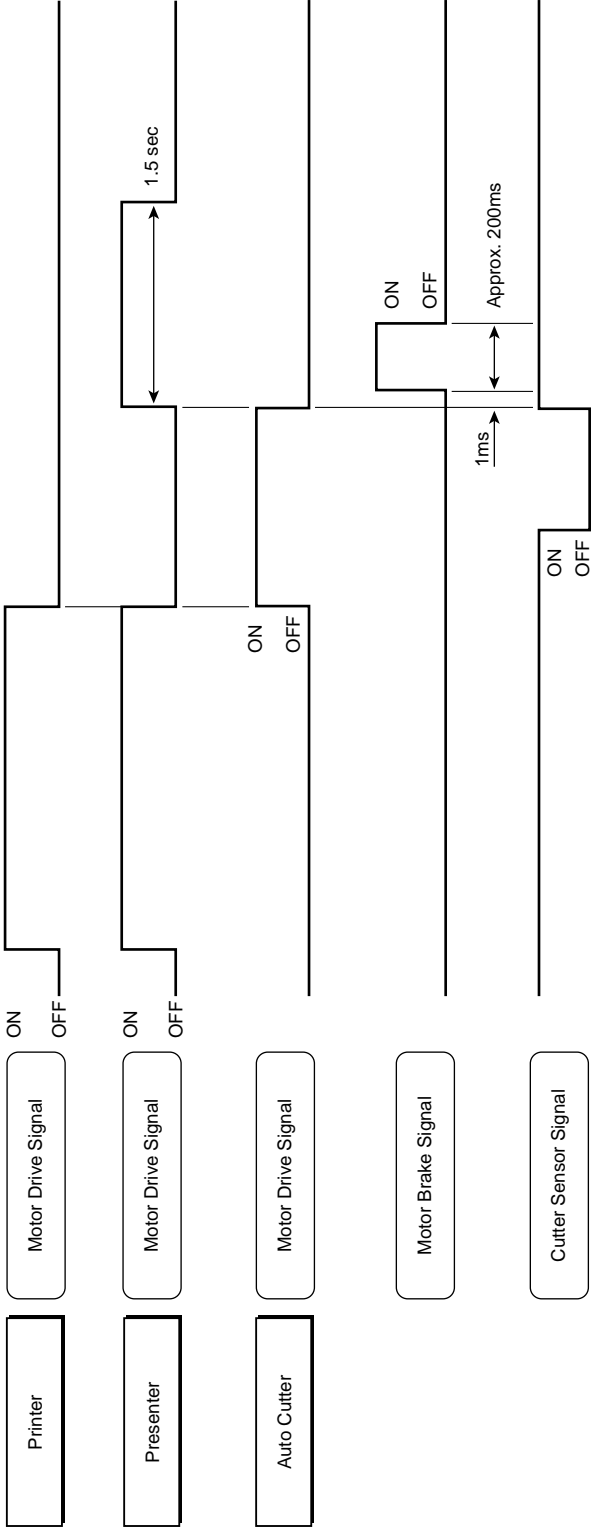

5.2 PPU Timing Chart (Controlled by paper sensor)

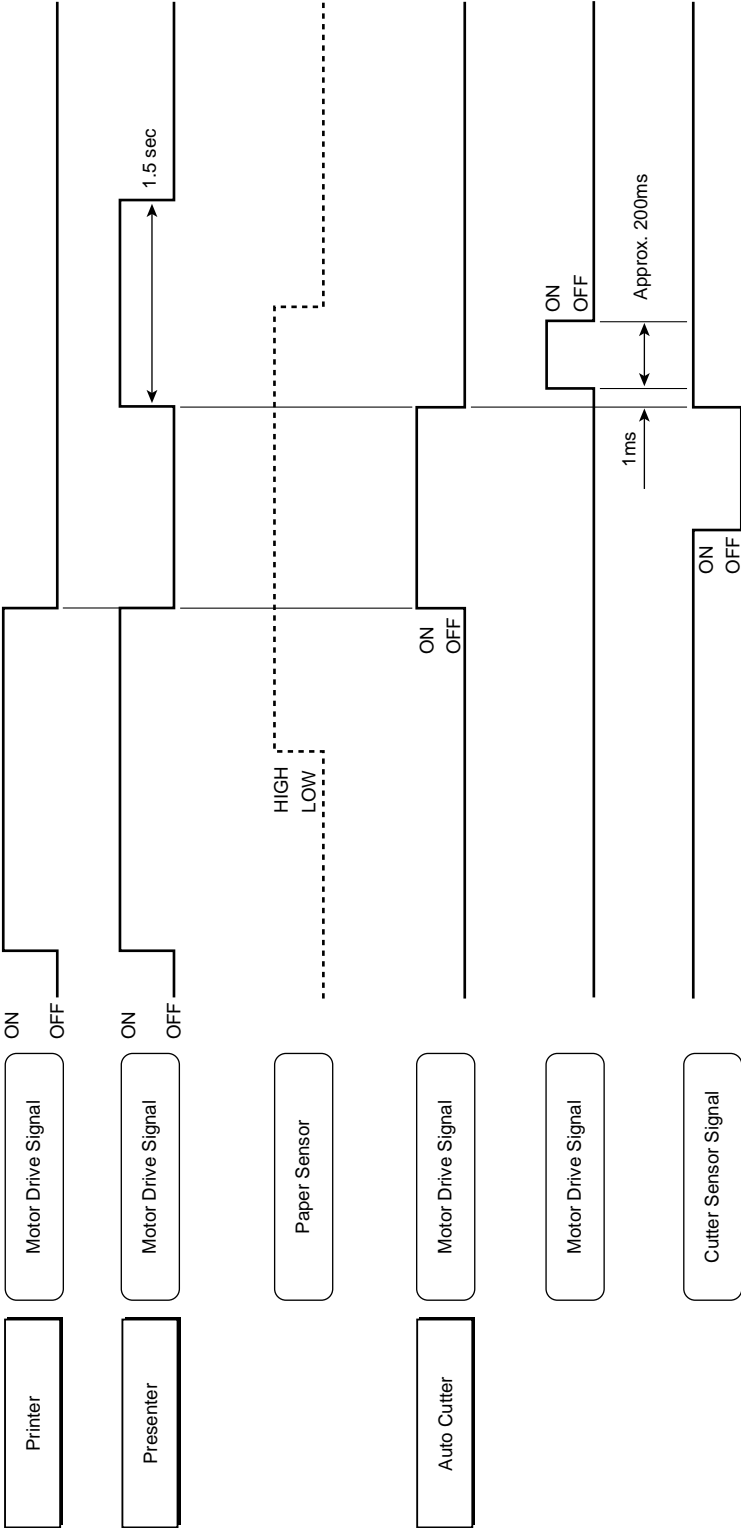

6. DESIGN CONSIDERATIONS

- (1) As mounting holes for the PRU and PMU units, \varnothing 2.7 mm burred holes are provided. So, when mounting them, use M3 tapping screws.
- (2) Refer to Sec. 2.3 for Designing PRU and PMU Unit Installation.
- (3) Exercise good care so that no unnecessary load is applied to the equipment and cables.
- (4) Make sure that there are no obstructing objects when opening/closing the PRU front door.
- (5) Avoid installing the equipment in a hot and/or humid place.
- (6) Avoid installing the equipment in a dusty place or where it is subjected to vibrations.

7. OPERATION

7.1 PRU (Presenter Unit)

7.1.1 Clearing Jams in the Presenter

- 1** Turn OFF the power.
- 2** Open the front door.
- 3** While rotating the roller with your hand, remove any paper from the inside completely.
- 4** Use a pair of tweezers to remove any paper jamming
- 5** Close the front door.

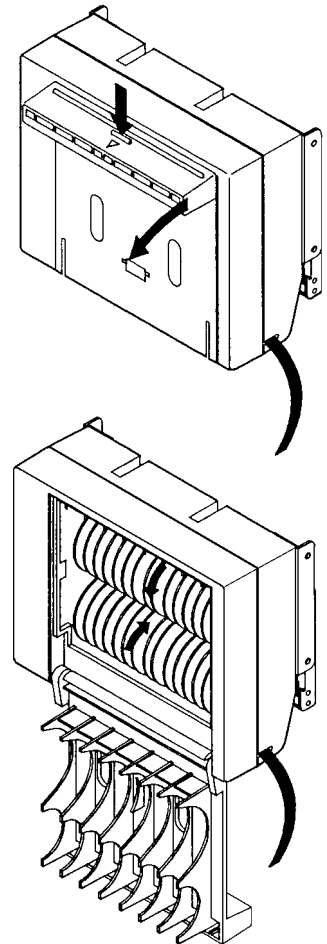

CAUTION:

- Do not try to rotate the roller forcibly or apply excessive force. This may damage the equipment.

7.1.2 Releasing a Locked Cutter

- 1** Referring to “7.1.1 Clearing Jams in the Presenter”, remove any paper in the paper path.
- 2** Turn ON the power. The auto-cutter initializes itself, and the blade is returned.
- 3** If the blade is not returned by the operation in step 2, turn OFF the power, and rotate the auto-cutter emergency knob in the direction of the arrow to have the auto-cutter blade returned.
- 4** Using a pair of tweezers, remove any paper remaining on and around the auto-cutter blade.

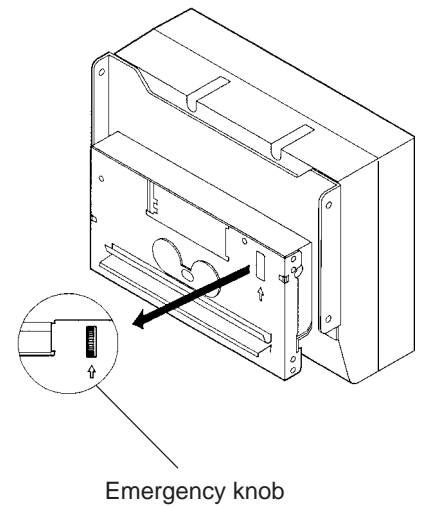

7.2 PMU (Printer Mechanism Unit)

7.2.1 Loading Printing Paper

- 1** Cut the edge of the paper roll approximately at a right angle and straight.
- 2** Check the winding direction of the paper roll, and then insert the paper roller into the paper roll.
- 3** Install the paper roller (on which the paper roll was set) in the paper holder.
- 4** Make sure that the printer is turned ON.

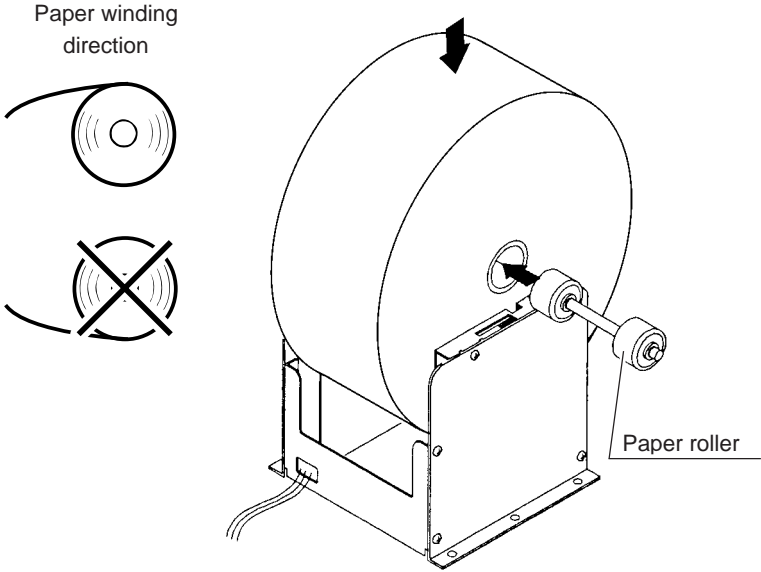
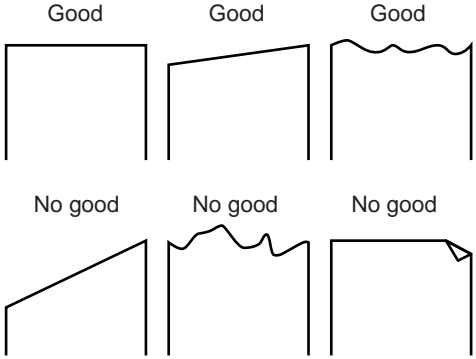

- 5 If residual paper is still remaining inside after a paper-out condition, remove it by referring to “7.2.2 Removing Residual Paper”.
- 6 Raise the head-up lever of the printer mechanism.
- 7 Insert the end of the paper roll straight into the paper insertion slot up until the paper comes to a stop.
- 8 Lower the head-up lever, and the printer is now ready to print.

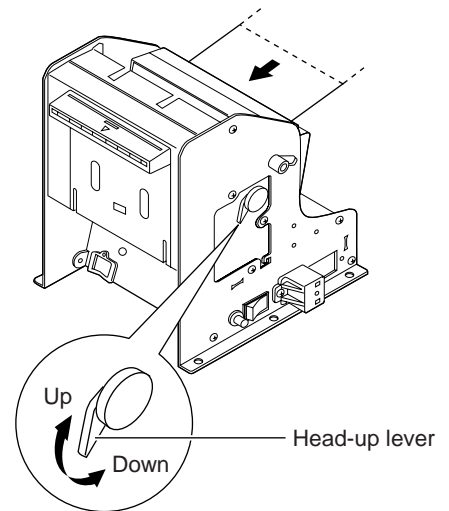

CAUTION:

- Always use the specified types of paper rolls.
- Use of paper other than specified may not guarantee print quality, head service life, presenter functions, etc.
- Do not insert paper into the presenter with its end fluffed or folded over. Otherwise, paper jams or improper paper insertion may result.
- If there is a slack in the paper, wind the paper roll back slightly to remove the slack.
- If the paper is set inclined, raise the head-up lever to correct, or pull the paper out once and then reinsert it.
- Do not hold or push on the paper while in printing. This may cause a paper jam.

7.2.2 Removing Residual Paper

- 1** Raise the head-up lever.
- 2** Pull the paper out slowly. The head moves away from the platen roller, allowing the paper to be pulled out.

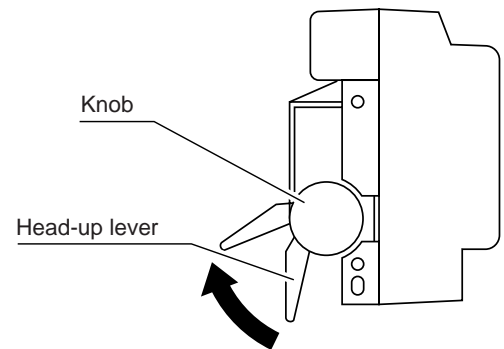

CAUTION:

- Never pull out the paper with the head-up lever left lowered. This may damage the head.
- Some mechanical parts of the printer may become HOT. Be extremely careful to do any printer related work immediately after printing.

7.2.3 Clearing Paper Jams

- 1** Turn the OFF power.
- 2** Cut apart the paper at a point near the paper insertion slot.
- 3** Move the knobs on both sides in the direction of the arrow to separate the printer mechanism and the auto-cutter.
- 4** Raise the head-up lever to move the head away from the platen roller.
- 5** Rotate the printer mechanism knob and remove any paper remaining in the paper path completely.
- 6** Lower the head-up lever, and return the printer mechanism to its original position.

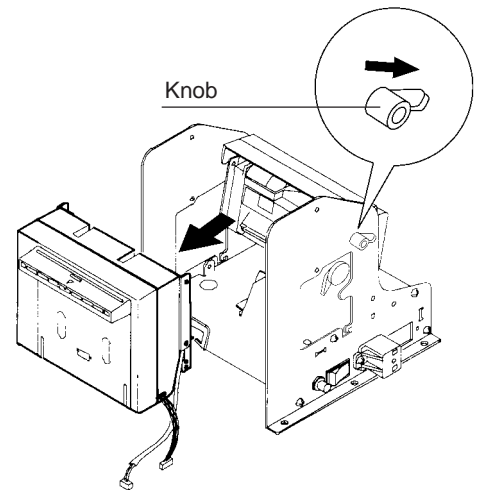
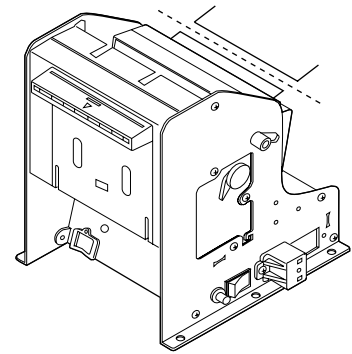

CAUTION:

- The head area is HOT. Avoid any printer-related work immediately after printing.
- While removing residual paper, be careful not to touch the heated surface of the head with a bare hand or any metal object.

7.3 PHU (Paper Holding Unit)

7.3.1 Loading a Paper Roll

- 1** Check the winding direction of the paper roll, and then insert the paper roller into the paper roll.
- 2** Install the paper roller (on which paper roll was set) in the paper holder.

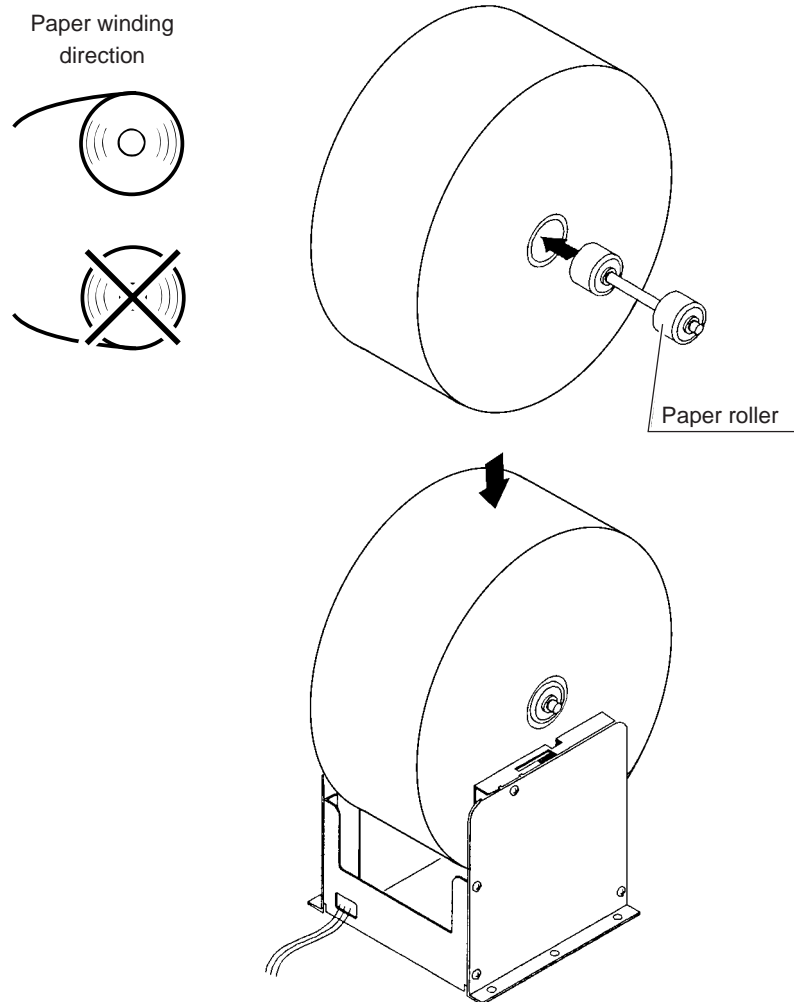

7.3.2 Paper-Near-End Sensor Function

- 1** When the paper supply becomes low, the PNE (Paper-Near-End) sensor outputs a signal, informing the host of this fact, and printing can be stopped.
- 2** The PNE sensor can be adjusted by loosening the screw on its top to allow up to 50-mm paper roll diameter.

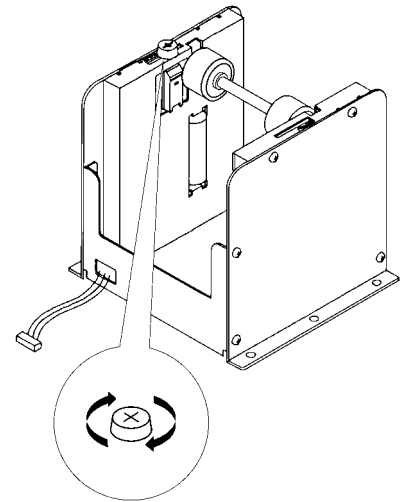

8. OUTLINE DRAWINGS

8.1 Outline Drawing for PRU-130

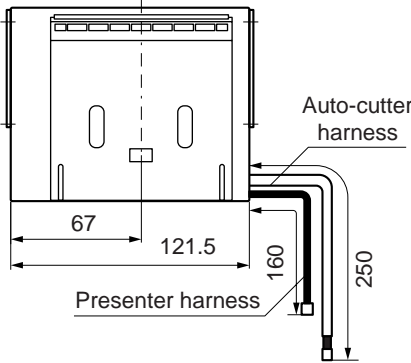
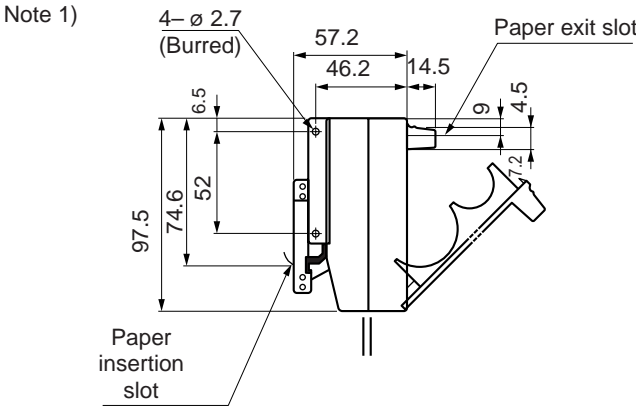
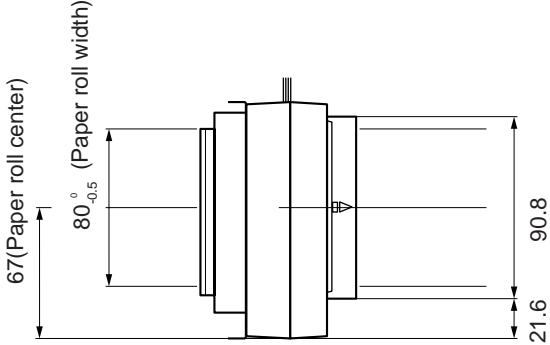

Note 1): Use M3 tapping screws.

Unit : mm

8.2 Outline Drawing for PMU-231

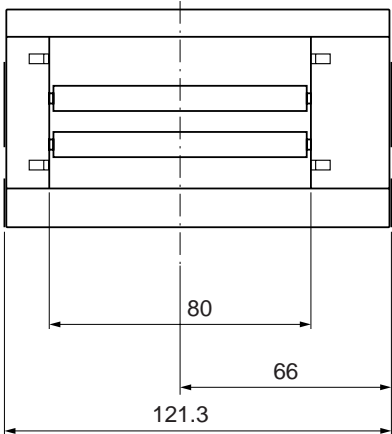

Note 1)

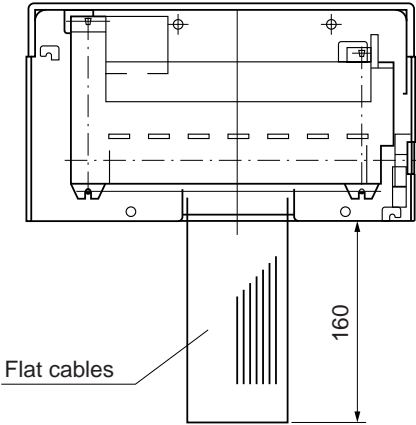
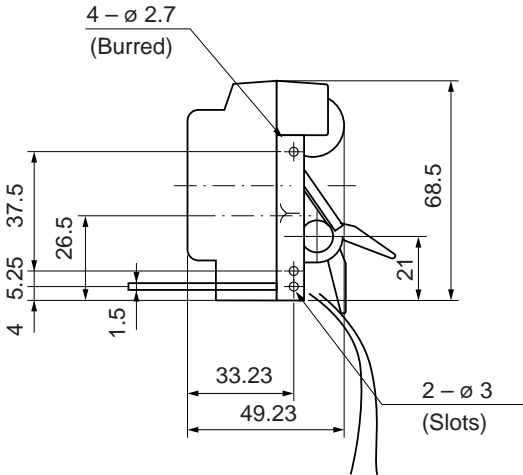

Note 1): Use M3 tapping screws.

Unit : mm

8.3 Outline Drawing for PHU-131/132

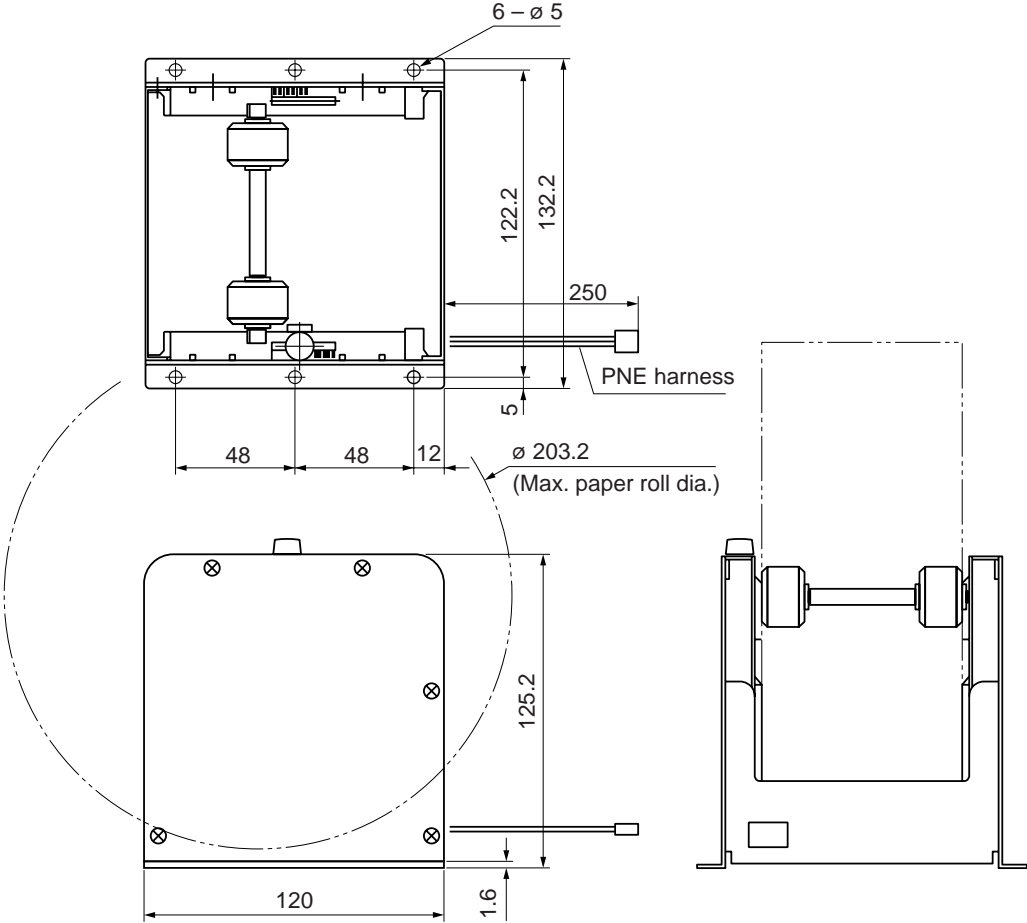

Unit : mm