

CITIZEN

*Thermal Transfer Barcode & Label Printer*

**CL-S6621 / CL-S6631**

**USER'S MANUAL**

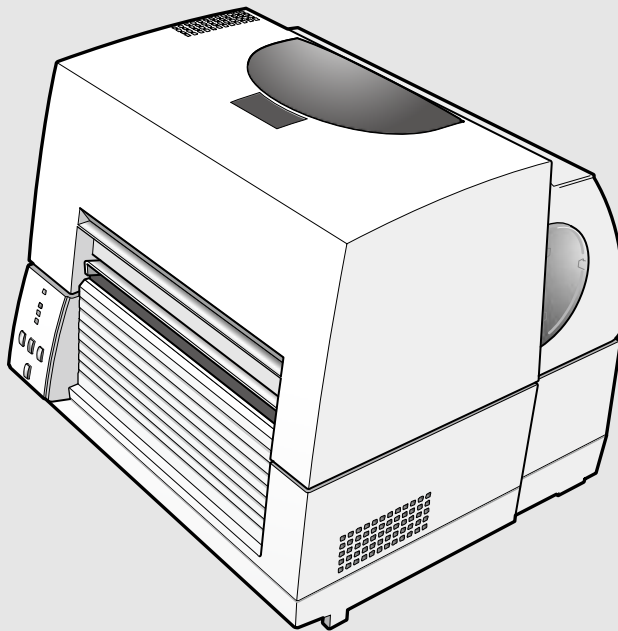

# WEEE MARK

- En** If you want to dispose this product, do not mix with general household waste. There is a separate collection systems for used electronics products in accordance with legislation under the WEEE Directive and is effective only within European Union.
- Ge** Wenn Sie dieses Produkt entsorgen wollen, dann tun Sie dies bitte nicht zusammen mit dem Haushaltsmüll. Es gibt im Rahmen der WEEE-Direktive innerhalb der Europäischen Union gesetzliche Bestimmungen für separate Sammelsysteme für gebrauchte elektronische Geräte und Produkte.
- Fr** Si vous souhaitez vous débarrasser de cet appareil, ne le mettez pas à la poubelle avec vos ordures ménagères. Il existe un système de récupération distinct pour les vieux appareils électroniques conformément à la législation WEEE sur le recyclage des déchets des équipements électriques et électroniques qui est uniquement valable dans les pays de l'Union européenne.  
Les appareils et les machines électriques et électroniques contiennent souvent des matières dangereuses pour l'homme et l'environnement si vous les utilisez et vous vous en débarrassez de façon inappropriée.
- Sp** Si desea deshacerse de este producto, no lo mezcle con residuos domésticos de carácter general. Existe un sistema de recogida selectiva de aparatos electrónicos usados, según establece la legislación prevista por la sobre residuos de aparatos eléctricos y electrónicos (RAEE), vigente únicamente en la Unión Europea.
- It** Se desiderate gettare via questo prodotto, non mescolatelo ai rifiuti generici di casa. Esiste un sistema di raccolta separato per i prodotti elettronici usati in conformità alla legislazione RAEE, valida solo all'interno dell'Unione Europea.
- Du** Deponeer dit product niet bij het gewone huishoudelijk afval wanneer u het wilt verwijderen. Er bestaat ingevolge de WEEE-richtlijn een speciaal wettelijk voorgeschreven verzamelstelsel voor gebruikte elektronische producten, welk alleen geldt binnen de Europese Unie.
- Da** Hvis du vil skille dig af med dette produkt, må du ikke smide det ud sammen med dit almindelige husholdningsaffald. Der findes et separat indsamlingsystem for udtjente elektroniske produkter i overensstemmelse med lovgivningen under WEEE-direktivet, som kun er gældende i den Europæiske Union.
- Por** Se quiser deitar fora este produto, não o misture com o lixo comum. De acordo com a legislação que decorre da Directiva REEE – Resíduos de Equipamentos Eléctricos e Electrónicos, existe um sistema de recolha separado para os equipamentos electrónicos fora de uso, em vigor apenas na União Europeia.
- Pol** Jeżeli zamierzasz pozbyć się tego produktu, nie wyrzucaj go razem ze zwykłymi domowymi odpadkami. Według dyrektywy WEEE obowiązującej w Unii Europejskiej dla używanych produktów elektronicznych należy stosować oddzielne sposoby utylizacji.



# CONTENTS

<b>WEEE MARK</b> .....	<b>2</b>
<b>INTRODUCTION</b> .....	<b>4</b>
COMPLIANCE STATEMENT FOR EUROPEAN USERS .....	5
IMPORTANT SAFETY INSTRUCTIONS .....	6
NOTICE .....	7
SAFETY INSTRUCTIONS .....	8
<b>Chapter 1 Setup</b> .....	<b>11</b>
Part Names and Functions .....	11
Connection to Power .....	17
Driver Installation .....	17
Connection to a Computer .....	18
<b>Chapter 2 Printer Operation</b> .....	<b>19</b>
Power ON/OFF .....	19
Normal Operating Mode .....	20
Setting the Media .....	22
Setting the Ribbon .....	33
Mode Settings .....	37
Quick Setup of the Print Method .....	46
Selecting the Ribbon Winding Direction .....	47
Emulation Auto Detect: Cross-Emulation™ .....	47
Manually Selecting the Printer Emulation .....	48
<b>Chapter 3 Printer Adjustments</b> .....	<b>49</b>
Sensor Adjustments .....	49
Media Thickness Adjustment .....	53
Media Width Adjustment .....	54
Adjusting the Ribbon .....	55
Cleaning .....	57
<b>Appendixes</b> .....	<b>58</b>
Troubleshooting .....	58
Specifications .....	61
Interfaces .....	66

# INTRODUCTION

Thank you for purchasing a Citizen CL-series label printer offering high performance thermal transfer printing on media up to 6 inches wide.

## **//// Main Features ////**

### ***<High-speed, high-quality printing>***

This printer can be used for high-speed high-quality printing thanks to its direct thermal method and thermal transfer method that use a line thermal printhead together with its 32 bit RISC CPU and its 'history control IC'.

### ***<Easy operation>***

- It is easy to change the printer's settings on the operation panel, thanks to its unique and simple VuePrint menu system.
- Its high-lift printhead and mechanism means that media and ribbon can be loaded with ease and it is constructed for easy thermal printhead cleaning, etc.
- Media width adjustment, media thickness adjustment, and media sensor adjustment can all be made easily by the user using the colour-coded operator controls.

### ***<Multi Programming Language>***

This printer contains the Datamax, Zebra® and Eltron® emulations and will automatically detect the language using the Cross-Emulation™ feature.

### ***<Interface>***

An industry standard RS232 serial port and USB2.0 port are standard equipment, for quick data transfer and printing.

### ***<Optional interface>***

Additional connectivity is available with an optional internally-housed IEEE1284 parallel port, an Ethernet interface and a wireless LAN print server.

### ***<Optional auto-cutter / peeler unit>***

The auto-cutter and peeler units are designed so that they can be installed easily.

### ***<Adjustable sensors>***

The adjustable media sensors - which allow the sensors to be positioned in different locations across the media - are standard features making the printer ideal for use with special media.

### ***<Installation>***

The interface, power switch etc. are installed towards the back and the top cover opens and closes vertically so that the sides of the printer are not restricted.

# COMPLIANCE STATEMENT FOR EUROPEAN USERS

CE marking shows conformity to the following criteria and provisions:

Low Voltage Directive (2014/35/EU), EMC Directive (2014/30/EU), and RoHS directive (2011/65/EU)

Full text of the EU declaration of conformity is available at the following internet address:

[http://www.citizen-systems.co.jp/en/printer/download/eu\\_doc.html](http://www.citizen-systems.co.jp/en/printer/download/eu_doc.html)

# IMPORTANT SAFETY INSTRUCTIONS

- Read all of these instructions and save them for later reference.
- Follow all warnings and instructions marked on the product.
- Unplug this product from the wall outlet before cleaning. Do not use liquid or aerosol cleaners. Use a damp cloth for cleaning.
- Do not use this product near water.
- Do not place this product on an unstable cart, stand or table. The product may fall, causing serious damage to the product.
- Slots and openings on the cabinet and the back or bottom are provided for ventilation. To ensure reliable operation of the product and to protect it from overheating, do not block or cover these openings. The openings should never be blocked by placing the product on a bed, sofa, rug or other similar surface. This product should never be placed near or over a radiator or heat register. This product should not be placed in a built-in installation unless proper ventilation is provided.
- This product should be operated from the type of power source indicated on the marking label. If you are not sure of the type of power available, consult your dealer or local power company.
- This product is equipped with a three-pronged plug, a plug having a third (grounding) pin. This plug will only fit into a grounding-type power outlet. This is a safety feature. If you are unable to insert the plug into the outlet, contact your electrician to replace your obsolete outlet. Do not defeat the safety purpose of the grounding-type plug.
- Do not allow anything to rest on the power cord. Do not locate this product where the cord will be walked on.
- If an extension cord is used with this product, make sure that the total of the ampere ratings on the products plugged into the extension cord do not exceed the extension cord ampere rating. Also, make sure that the total of all products plugged into the wall outlet does not exceed 15 amperes for 120V outlet and 7.5 amperes for 220V-240V outlet.
- Never push objects of any kind into this product through cabinet slots as they may touch dangerous voltage points or short out parts that could result in a risk of fire or electric shock. Never spill liquid of any kind on the product.
- Except as explained elsewhere in this manual, don't attempt to service this product yourself. Opening and removing those covers that are marked "Do Not Remove" may expose you to dangerous voltage points or other risks. Refer all servicing on those compartments to service personnel.
- The mains plug on this equipment must be used to disconnect mains power. Please ensure that the socket outlet is installed near the equipment and shall be easily accessible.
- Unplug this product from the wall outlet and refer servicing to qualified service personnel under the following conditions:
  - A. When the power cord or plug is damaged or frayed.
  - B. If liquid has been spilled into the product.
  - C. If the product has been exposed to rain or water.
  - D. If the product does not operate normally when the operating instructions are followed. Adjust only those controls that are covered by the operating instructions since improper adjustment of other controls may result in damage and will often require extensive work by a qualified technician to restore the product to normal operation.
  - E. If the product has been dropped or the cabinet has been damaged.
  - F. If the product exhibits a distinct change in performance, indicating a need for service.

# NOTICE

- Before use, be sure to read this manual. And keep it handy for reference when needed.
- The contents of this manual may change without prior notice.
- Reproduction, transfer, or transmission of the contents of this manual without prior consent is strictly prohibited.
- We are not liable for any damage resulting from the use of the information contained herein, regardless of errors, omissions, or misprints.
- We are not liable for any problems resulting from the use of optional products and consumable supplies other than the designated products contained herein.
- Do not handle, disassemble or repair the parts other than those specified in this manual.
- We are not liable for any damage caused by user's erroneous use of the printer and inadequate environment.
- Data residing in the printer is temporary. Therefore, all data will be lost if power is lost. We are not liable for any damage or loss of profits caused by data loss due to failures, repairs, inspections, etc.
- Please contact us if there are any mistakes or ambiguities within this manual.
- If there are missing or incorrectly collated pages in this manual, contact us to obtain a new manual.

Use of the Made for Apple badge means that an accessory has been designed to connect specifically to the Apple product(s) identified in the badge and has been certified by the developer to meet Apple performance standards. Apple is not responsible for the operation of this device or its compliance with safety and regulatory standards. Please note that the use of this accessory with an Apple product may affect wireless performance.





CITIZEN is a registered trademark of Citizen Watch Co., Ltd.  
CITIZEN est une marque enregistrée de Citizen Watch Co. Ltd.

Copyright © 2018 by CITIZEN SYSTEMS JAPAN CO., LTD.

# SAFETY INSTRUCTIONS

## which must be strictly observed!

- To prevent personal injury or property damage, the following shall be strictly observed.
- The degree of possible injury and damage due to incorrect use or improperly following instructions is described below.

 <b>Warning</b>	Indicates a situation which, if not observed and handled properly, could result in death or serious injury.
 <b>Caution</b>	Indicates a situation which, if not observed and handled properly, could result in injury.
 <b>Caution</b>	The parts near the mark become hot. Do not touch them during or immediately after operation. Doing so may result in burns.
 <b>Warning</b>	There is a cutter at the paper ejection port. Do not put your fingers in this area, as touching it may cause injury.

 : This is a mark to call attention to the reader.

## Warning

**Never perform the following. If not avoided, these may cause damage or trouble to the printer or cause the printer to overheat and release smoke and cause burns or an electrical shock. If the printer is damaged or is malfunctioning, be sure to turn the printer off immediately and remove the power cord from the outlet, then consult our service personnel.**

- Do not place the printer in a poorly ventilated area, or shut off the air vent of the printer.
- Do not place the printer where chemical reactions occur, such as in laboratories or where air is mixed with salt or gas.
- Do not use a power voltage or frequency other than those specified.
- Do not plug/unplug the power cord or attach/detach the interface cable by simply grabbing the power cord or interface cable. Do not pull or carry the printer when the tension of the power cord or interface cable is increased.
- Do not drop or put foreign matter such as clips and pins into the printer. This may cause problems.
- Do not plug the power cord into an outlet with many loads.
- Do not spill drinks such as tea, coffee and juice on the printer or spray insecticide on the printer. If drink or water is spilled, first be sure to turn the power off and remove the power cord from the outlet, then consult our service personnel.
- Do not disassemble or modify the printer.

**Discard or safely store the plastic packing bag. This bag should be kept away from children. If the bag is pulled over a child's head, it may cause suffocation.**

## General Precautions

### Caution

- Prior to operation, read the safety instructions carefully and observe them.
- Do not drop or put foreign matter such as clips and pins into the printer. This may cause problems.
- Be careful when moving or carrying the printer. Dropping the printer may cause injury or property damage.
- Make sure if you open the top cover, it is opened all the way. If only partially open, the cover could slam shut, possibly causing injury.
- When the cover is open, be careful of the corners of the cover. They could cause injury.
- Do not open the printer during printing.
- When cleaning the surface of the printer case, do not use the cloth that is soaked in thinner, trichloroethylene, benzene, ketone or similar chemicals.
- Do not use the printer where there is a lot of oil, iron particles, or dust.
- Do not spill liquids or spray insecticide on the printer.
- Do not jolt or impact to the printer by stepping on, dropping or hitting the printer.
- Operate the control panel properly. A careless, rough handling may cause problems or malfunction. Do not use such sharp-edged tool as a ballpoint pen for operation.
- Be careful of the edges of the plates so injury or property damage is possible.
- If a problem occurs during printing, stop the printer immediately and unplug the power cord from the outlet.
- When printer trouble occurs, do not try to disassemble it. Instead, consult our service personnel.

## Precautions When Installing the Printer

### Caution

- Prior to operation, read the safety instructions carefully and observe them.
- Do not use or store the printer near fire, excessive moisture, in direct sunlight, near an air conditioner or heater or other source of unusually high or low temperature or humidity or excessive dust.
- Do not place the printer where chemical reactions occur, such as in a laboratory.
- Do not place the printer where air is mixed with salt or gas.
- The printer must sit on a firm, level surface where there is ample ventilation. Never allow the printer's air vent to be blocked by a wall or other object.
- Do not put anything on the top of printer.
- Do not place the printer near a radio or television, and do not use the same wall outlet for the printer and radio or television. Radio or television reception could be adversely affected.
- Do not put anything on the power cord or step on it.
- Do not drag or carry the printer with the power cord or interface cable.
- Avoid plugging the power cord into an outlet with many loads.
- Do not bundle the power cord when inserting the plug.
- Always grip the plug housing, not the cord, to plug/unplug the power cord.
- Make certain the power is turned off before connecting/disconnecting the interface cable.
- Avoid lengthening the signal cable or connecting it to any noise-producing device. If it is unavoidable, use the shielded cable or twisted pair for each signal.
- Place the printer near the outlet where the power cord can be unplugged easily to shut off power.
- Use the AC outlet that accepts a three-pronged plug. Otherwise, static electricity may be generated and there will be danger of electric shock.

# Chapter 1 Setup

---

## Part Names and Functions

### Front View

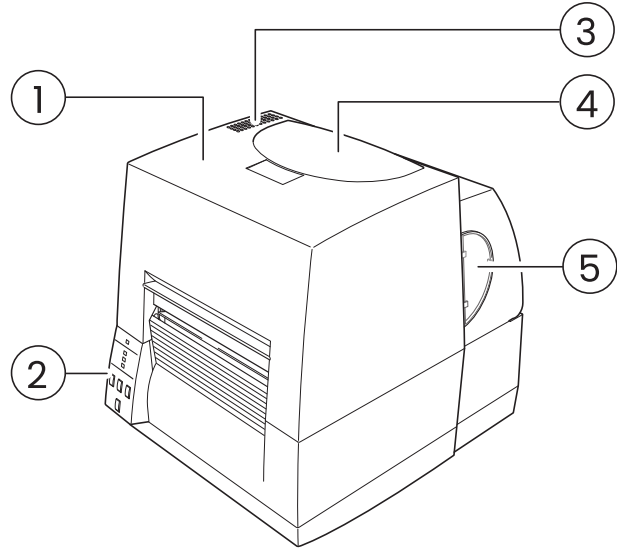

**① Top cover**

Is opened vertically to set media or ribbon.

**② Operation panel**

This is used to make changes and adjustments to the printer and its configuration.

**③ Heat discharge vent**

It allows warm air to vent from the printer.

Be sure not to block it with media etc.

**④ Ribbon window**

The amount of ribbon remaining can be checked through this window.

**⑤ Media window**

The amount of media remaining can be checked through this window.

## Part Names and Functions

### Inside the printer

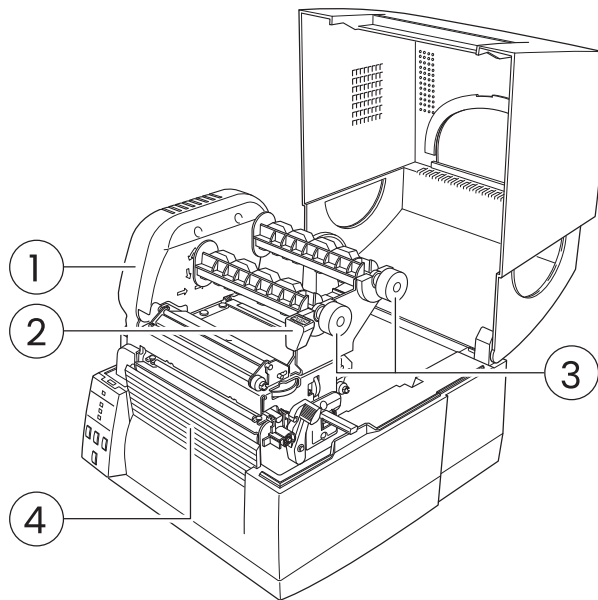

① **Ribbon drive unit**

② **Head close knob**

Push the head close knob to lock the mechanism closed. If you push on another part of the mechanism, the printer may not lock closed correctly.

③ **Ribbon holder**

It is used to attach the ribbon and paper core.

④ **Front cover**

It is removed to install optional units such as the peeler or cutter.

# Chapter 1 Setup

## Part Names and Functions

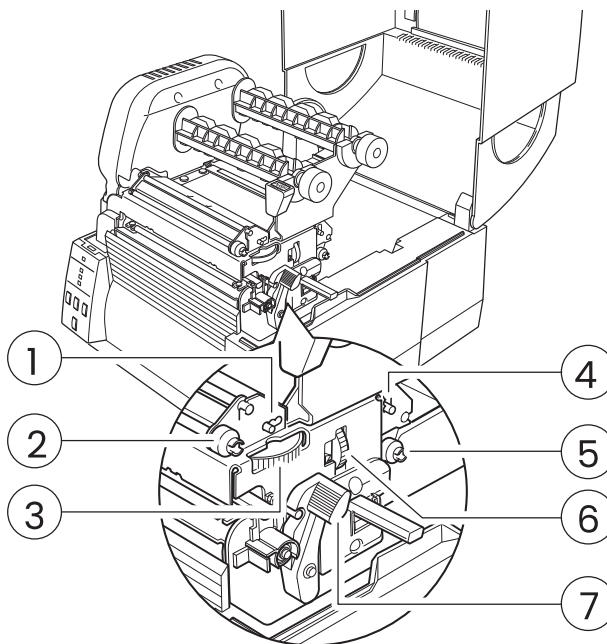

*Ribbon Tension Adjustment (P.55)*

*Ribbon Balance Adjustment(P.56)*

*Media Width Adjustment(P.54)*

*Ribbon Tension Adjustment (P.55)*

*Ribbon Balance Adjustment(P.56)*

*Media Thickness Adjustment(P.53)*

- ① Front (winding side) ribbon tension adjustment knob**  
This is adjusted according to the width of the ribbon that is used. It is also used when the ribbon is wrinkled or slips.
- ② Front (winding side) ribbon left-right balance adjustment knob**  
It is used to perform an adjustment when the ribbon is wrinkled. Normally set it to the center position.
- ③ Media width adjustment dial**  
It is adjusted to match the width of the media.
- ④ Back (feeding side) ribbon tension adjustment knob**  
This is adjusted according to the width of the ribbon that is used. Use it basically in the same way as the front adjustment knob.
- ⑤ Back (feeding side) ribbon left-right balance adjustment knob**  
It is used to perform an adjustment when the ribbon is wrinkled. Normally set it to the center position.
- ⑥ Media thickness adjustment dial**  
It is adjusted to match the thickness of the media.
- ⑦ Large blue-head open lever**  
The head unit can be raised to install media by pushing this lever. It locks the head unit during printing.

## Part Names and Functions

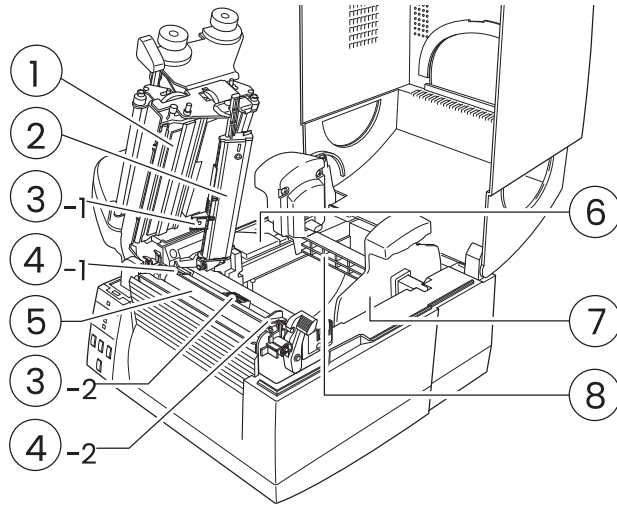

*Sensor*

*Adjustments(P.49)*

*Loading roll  
media(P.23)*

**① Thermal printhead**

This is the printhead. Avoid touching this with your fingertips and leaving grease or dirt on the printhead surface.

**② Sensor arm**

The media can be installed by raising this arm.  
The media can be held in place by lowering this arm.

**③ Upper sensor (③-1) and bottom sensor (③-2)**

Settings for sensor position and sensor adjustment should be performed in accordance with the type of sensor used.

**④ Media guides (Left fixed media guide (④-1)  
and right movable media guide (④-2))**

The end of the media is matched to the left fixed media guide, then the right side movable media guide is moved horizontally to match it to the media size. And the movable media guide is used as a guide to match the upper sensor and bottom sensor when using a label detection sensor (Transparent sensor).

**⑤ Platen**

Interlocked with the thermal printhead, it feeds media backwards or forwards.

**⑥ Optional unit connector cover**

It is opened when the cables of the cutter unit and the peeler unit are connected. Do not remove during normal use.

**⑦ Media holder guide**

This guide is moved horizontally to match the media size. The guide can be sliding it from the holder bar.

**⑧ Media holder bar**

The media is supported by the media holder bar when installed in the printer.

## Part Names and Functions

### Operation Panel

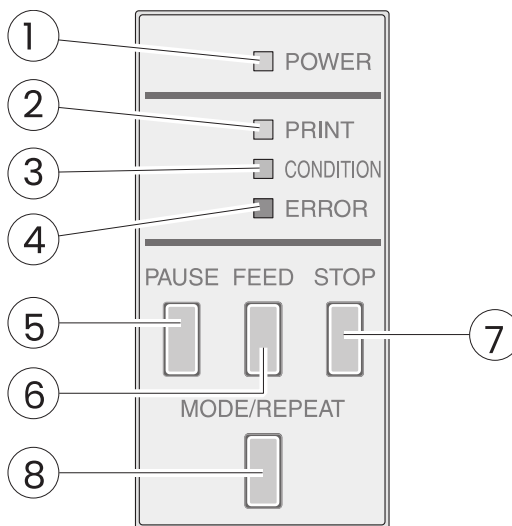

*LED Functions(P.21)*

**① POWER LED**

This is lit when the printer power is on. (green)

**② PRINT LED**

This is lit when the printer is able to print. (green)

**③ CONDITION LED**

This is on when selecting settings. (orange)

**④ ERROR LED**

This is lit or flashes when the printer is in an alarm or error status. (red)

*Normal Operating Mode(P.20)*

**⑤ PAUSE key**

This temporarily stops printing.

**⑥ FEED key**

This key feeds the media to the top of the next label or form.

**⑦ STOP key**

This stops printing or cancels the alarm.

**⑧ MODE/REPEAT key**

This key exits current status in the menu setting mode or reprints the final label, depending on printer status.

## Part Names and Functions

### Rear View

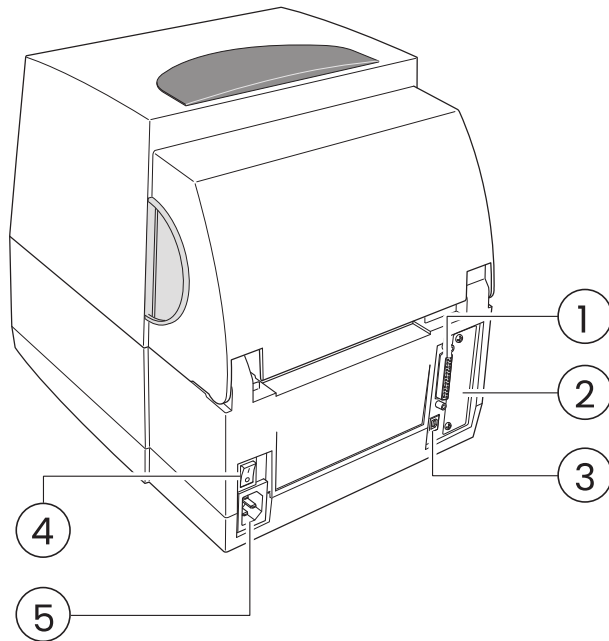

*Serial  
Interface(P.66)*

**① Serial interface (RS-232C)**

This receives serial transmission of data from a host computer.

**② Option interface**

Additional option interface boards can be mounted.  
Contact your retailer if you want to use the option interface.

*USB  
Interface(P.68)*

**③ USB interface**

This receives USB transmission of data from a host computer.

*Power  
ON/OFF(P.19)*

**④ Power switch**

The is the power switch for the printer.

*Connection to  
Power(P.17)*

**⑤ Power cord inlet**

The connector of the enclosed power cord is connected here.

## Connection to Power

### Caution

Do not use any voltage other than that displayed. Doing so may lead to damage or malfunction.

1. Check that the power switch to the printer is turned OFF.
2. Connect the connector of the power cord to the power cord inlet on the printer.
3. Insert the plug of the power cord in the AC outlet.



### Caution

Use an AC outlet that accepts a three-pronged plug. Otherwise, static electricity may be generated and there will be danger of electric shock.

## Driver Installation

Install the printer driver onto the host computer. Printer drivers are available for download from the Citizen Systems support website.

The latest documentation, drivers, utilities, and other support information are also available from this website.

<https://www.citizen-systems.co.jp/en/printer/download/>

Once a printer driver has been downloaded, follow the on-screen instructions to install the driver.

### Connection to a Computer

This product has two interfaces that can be used to receive printing data: a serial port (RS-232C) and a USB port (USB2.0). An optional internal Ethernet, an IEEE1284 Parallel or Wireless LAN port can be added by your dealer.

With the exception of a wireless LAN connection, an interface cable is necessary to connect the printer to a computer.

To connect the cable, proceed as follows:

1. Turn OFF both power switches of the printer and the computer.
2. Connect one end of the interface cable to the interface connector on the back of the printer and secure it with locks or locking screws, where available.
3. Connect the other end of the interface cable to the interface connector on the computer and secure it with locks or locking screws, where available.

*Serial  
Interface (P.66)  
USB  
Interface (P.68)*

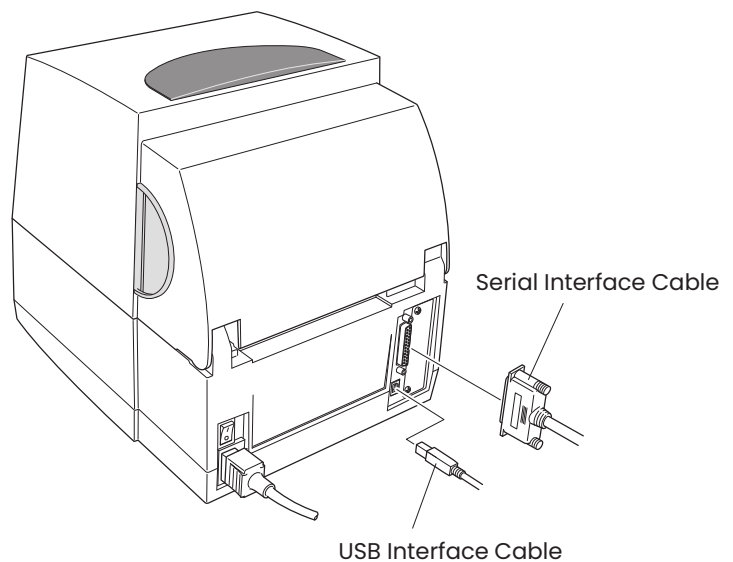

**Note:** If an optional Ethernet, an IEEE1284 Parallel or Wireless LAN port is used, contact your Citizen Systems dealer.

# Chapter 2 Printer Operation

## Power ON/OFF

### Turning on the power

1. Turn on the power switch on the back of the printer.
2. The POWER and PRINT LED are lit.

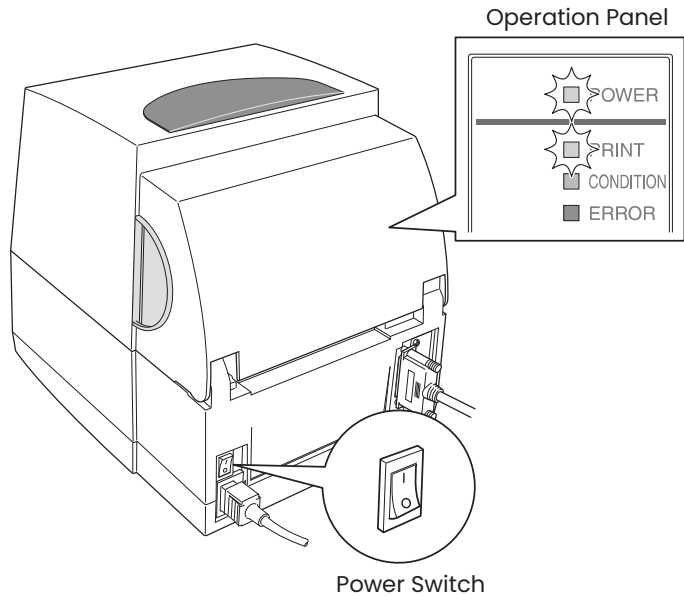

### Turning off the power

1. Turn off the power switch on the back of the printer.
2. The POWER and PRINT LED go off.

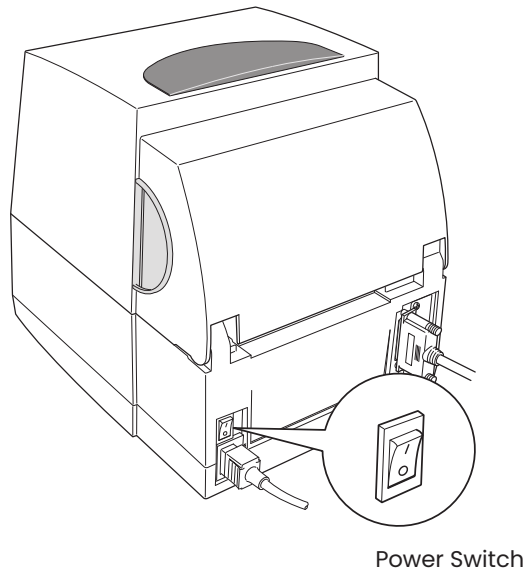

*Menu Setup Mode  
(P.39)*

### Normal Operating Mode

When the power is turned on, the printer enters normal operating mode. The control keys activate the following functions.

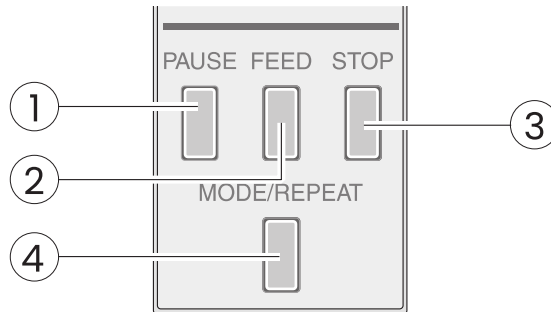

**① PAUSE key: Temporarily pauses printing**

- When this key is pushed once, the PRINT LED turns off and the printer temporarily pauses.
- When it is pushed during printing, the printer pauses after the label currently being printed is issued. Pressing the key a second time restarts printing and the remaining number of designated labels are printed.

**② FEED key: Feeds media**

- Pressing this key feeds media to the print start position. The distance it is fed is determined by automatically detecting the front end of the media when using label media, and when continuous media has been designated, a fixed quantity is fed, then feeding stops.
- When the TEAR OFF setting is effective, feeding stops when the media has been fed to the TEAR OFF location.
- When the optional cutter unit is installed, the media is fed to the cut position then it is cut.
- If the optional peeler unit is installed, the media is fed to the peeling location. When the media is pausing at the peeling position, feeding does not occur, even if the FEED key is pushed.

**③ STOP key: It stops printing and cancels the alarm**

- Pushing this key once during printing puts the printer in pause mode after the label is issued. It is possible to cancel 1 batch of label issuing data by pressing the STOP key for 4 seconds or longer in pause status. (The PRINT LED flashes at high speed during cancel.)
- Pushing this key once cancels the abnormal head resistance alarm.

**④ MODE/REPEAT key:**

- Pressing this key reprints the last label in PRINT status (when the PRINT LED is lit) The last label issued depends on the selection of the "MODE/REPEAT key" menu.

## Normal Operating Mode

### LED Functions

**① POWER LED**

It lights up when printer power is turned on. (green)

**② PRINT LED**

This is lit when the printer is able to print. (green)

**③ CONDITION LED**

This is on when selecting settings. (orange)

**④ ERROR LED**

This is lit or flashes when the printer is in error status. (red)

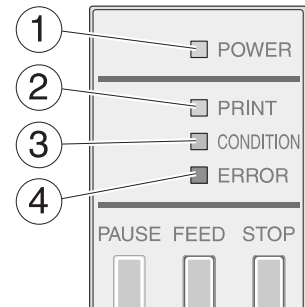

### Table of Alarm and Error Indications

In addition to normal operating mode, when an abnormal condition is detected in the printer, an alarm sounds and each LED either lights up or flashes to indicate the type of error.

Item	PRINT LED	CONDITION LED	ERROR LED
When the STOP key has been pushed	OFF	OFF	OFF
Abnormal head temperature	<input type="checkbox"/> ON <input checked="" type="checkbox"/> OFF	<input type="checkbox"/> ON <input checked="" type="checkbox"/> OFF	OFF
Abnormal motor temperature	<input type="checkbox"/> ON <input checked="" type="checkbox"/> OFF	<input checked="" type="checkbox"/> OFF <input type="checkbox"/> ON	OFF
Head open	OFF	OFF	○●○●○●○●
Media end	OFF	OFF	<input type="checkbox"/> ON <input checked="" type="checkbox"/> OFF
Media out (media location cannot be detected)	OFF	<input type="checkbox"/> ON <input checked="" type="checkbox"/> OFF	<input type="checkbox"/> ON <input checked="" type="checkbox"/> OFF
Abnormal head resistance*1	OFF	<input type="checkbox"/> ON <input checked="" type="checkbox"/> OFF	<input checked="" type="checkbox"/> OFF <input type="checkbox"/> ON
Ribbon feed error	OFF	○●○●○●○●	○●○●○●○●
Ribbon end	OFF	○●○●○●○●	●●○●○●○●
Communication error (reception buffer overrun)	OFF	<input type="checkbox"/> ON <input checked="" type="checkbox"/> OFF	OFF
Communication error (parity, framing)			
Communication error (transmission buffer overflow)			
System error	OFF	○●○●○●○●	ON
Auto cutter abnormality (jamming etc.)	OFF	OFF	ON
Auto cutter temperature abnormal	<input type="checkbox"/> ON <input checked="" type="checkbox"/> OFF	<input checked="" type="checkbox"/> OFF <input type="checkbox"/> ON	OFF
Paper near end*2	ON	OFF	<input type="checkbox"/> ON <input checked="" type="checkbox"/> OFF

\*1 Pushing the STOP key once cancels the alarm.

\*2 Only displayed when the Paper Near End Alarm setting under Menu Setup Mode is On. The buzzer will not sound while the alarm is displayed.

Time Axis → ○ : ON, ● : OFF  
 Wide on/off marks indicate slow LED flashing.  
 Small circle on/off marks indicate quick LED flashing.

## Setting the Media

### Media Sizes

The position of label and tag media is sensed by either a label detection sensor (Transparent sensor) or a black mark detection sensor (Reflective sensor).

Label detection sensor (Transparent sensor):

Detects the gaps between label media and notches of tag media

Black mark detection sensor (Reflective sensor) : Detects the black mark

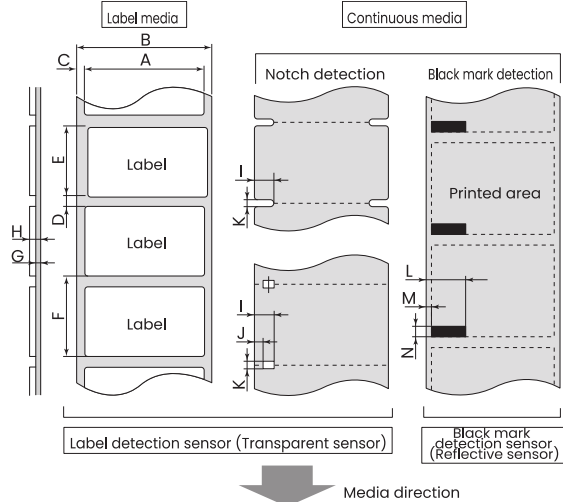

		Min. value mm (inches)	Max. value mm (inches)
A	Label width	50.0 (1.97)	178.0 (7.01)
B	Liner width	50.0 (1.97)	178.0 (7.01)
C	Label left edge position	0 (0)	2.54 (0.10)
D	Length of gap between labels	3 (0.12)	2539.7* (99.99*)
E	Label length	16 (6.30)	2539.7* (99.99*)
F	Label pitch	19 (7.48)	2539.7* (99.99*)
G	Liner thickness	0.06 (0.0025)	0.125 (0.0049)
H	Total media thickness	0.06 (0.0025)	0.25 (0.01)
I	Position of right edge of notch	6.00 (0.24)	60.80 (2.39)
J	Position of left edge of notch	0 (0)	57.20 (2.25)
K	Notch length	2.54 (0.10)	17.80 (0.70)
L	Right edge of black mark	15.00 (0.59)	66.50 (2.62)
M	Left edge of black mark	0 (0)	51.5 (2.02)
N	Black mark width	3.18 (0.125)	17.80 (0.70)

- Use a label detection sensor (Transparent sensor) for label media gaps and media with black marks.
- Use the continuous media detection sensor (Reflective sensor) for continuous media with no notches or black marks.
- Use a label detection sensor (Transparent sensor) for fan fold media.
- If the label pitch is 1 inch or less, set the Small Media Adjustment menu to ON and match it to the label that uses the value of the Small Media Length menu.

\* For CL-S6631, the value is 1625.6 mm (64.00 inch)

Menu Setting  
Table(P.42)

### Setting the Media

*Setting the Paper  
Near End Sensor  
(P.32)*

*Media Sizes (P.22)*

#### Loading roll media

1. Push the large blue-head open lever to release the head unit, and then lift the sensor arm by hand as shown below.

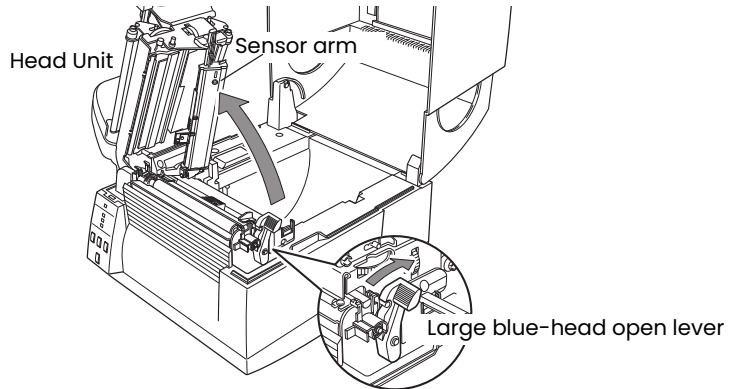

2. Firstly, slide the two black plastic parts of the media holder assembly together. Ensure correct alignment of the guide with the bar as it can only be installed in one direction. When using the Paper Near End Sensor, sensor position settings should be performed. See "Setting the Paper Near End Sensor" for how to perform the settings. (These settings are off when the product is shipped from the factory)
3. Slide the roll of media over the media bar. The media guide must be on the right side of the roll of media (as viewed from the front of the printer) with the ribbed surface of the media guide touching the media roll as shown in the illustration.

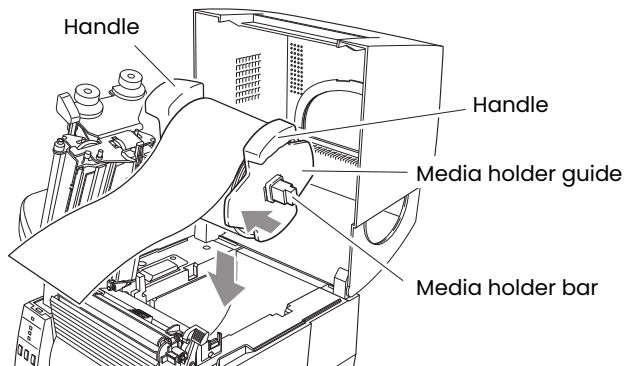

4. Set the media roll and media holder into the printer as shown above. It is advisable to pull a length of media forwards and through the mechanism ready for later positioning. When lifting the media, use the handles on the media holder placed on either side.

### Setting the Media

5. Move the media roll so it is touching the left side of the housing. Then slide the black media guide so it is touching the media on the right side.

**Note:** Do not try to hold the media too tightly with these guides as it will cause the printer to jam during printing.

6. **Select a sensor.**

Ensure the POWER LED and PRINT LED are lit, then push the STOP key for at least 4 seconds while pushing the MODE/ REPEAT key.

Each time the key is pushed, the buzzer sounds and the selected sensor switches between the label detection sensor (transparent sensor), black mark detection sensor (reflective sensor) and continuous media detection sensor (reflective sensor).

When the label detection sensor (transparent sensor) is selected, the buzzer sounds once.

When the black mark detection sensor (reflective sensor) is selected, the buzzer sounds twice.

When the continuous media detection sensor (reflective sensor) is selected, the buzzer sounds thrice.

7. **Setting sensor positions.**

Lower the sensor arm and turn the knob, the upper sensor and bottom sensor will both move together.

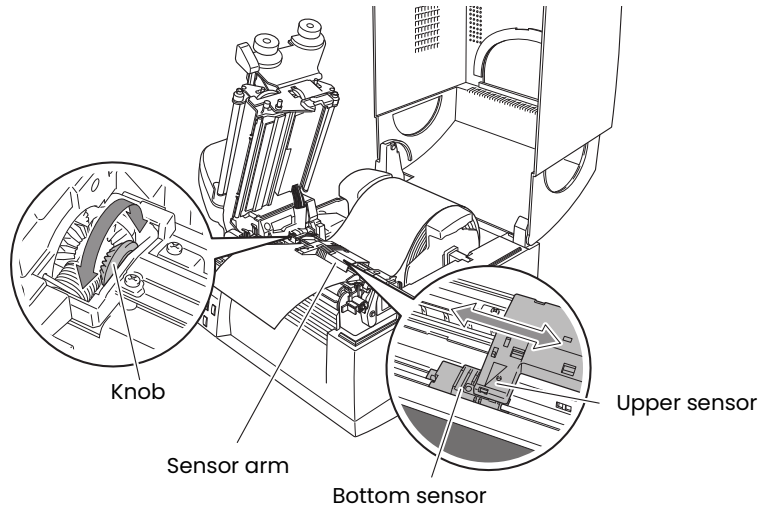

### Setting the Media

*Quick Sensor  
Selection Method  
(P.49)*

*Adjusting the label  
detection sensor  
(Transparent sensor)  
(P.50)*

*Adjusting the black  
mark detection  
sensor (Reflective  
sensor) (P.51)*

#### **When using a label detection sensor (transparent sensor)**

Move the upper sensor and bottom sensor close to the center of the width of the media.

When using media that is 6 inches wide, position the upper sensor and the bottom sensor all the way to the right (large blue-head open lever side).

Be careful that media with black marks does not pass the media sensor.

### **! Caution**

The bottom sensor and upper sensor must be in alignment with each other.

#### **When using a black mark detection sensor (Reflective sensor)**

Adjust the position of the sensor so that the black mark detection sensor (Reflective sensor) marker of the bottom sensor is at the center of the black mark of the media as shown below.

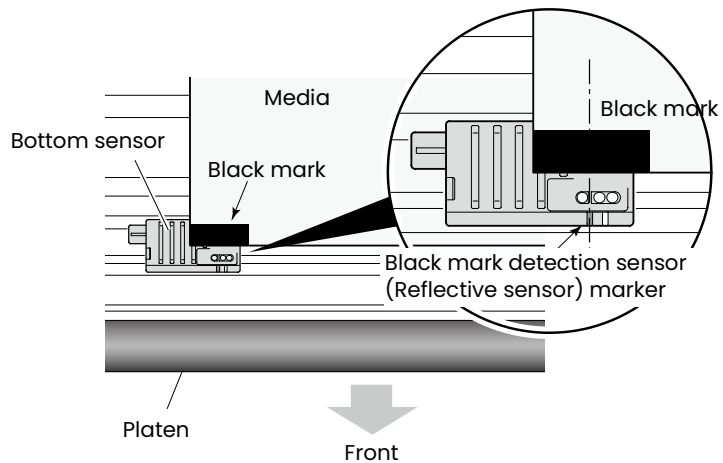

### **! Caution**

Do not install the upper sensor directly above the bottom sensor. Normal operation may not be possible.

### Setting the Media

*Adjusting the continuous media detection sensor (Reflective sensor) (P.51)*

#### **When using the continuous media detection sensor (reflective sensor)**

Move the bottom sensor close to the center of the width of the media. Be careful that media with black marks does not pass the media sensor.

When using media that is 6 inches wide, position the bottom sensor all the way to the right (large blue-head open lever side).

### **Caution**

Do not install the upper sensor directly above the bottom sensor. Normal operation may not be possible.

- 8. Lift the sensor arm up temporarily and adjust the media guide. Align the media with the fixed media guide on the left side, and then align the moveable media guide on the right side with the width of the media. Lower the sensor arm and fix the media in place.**

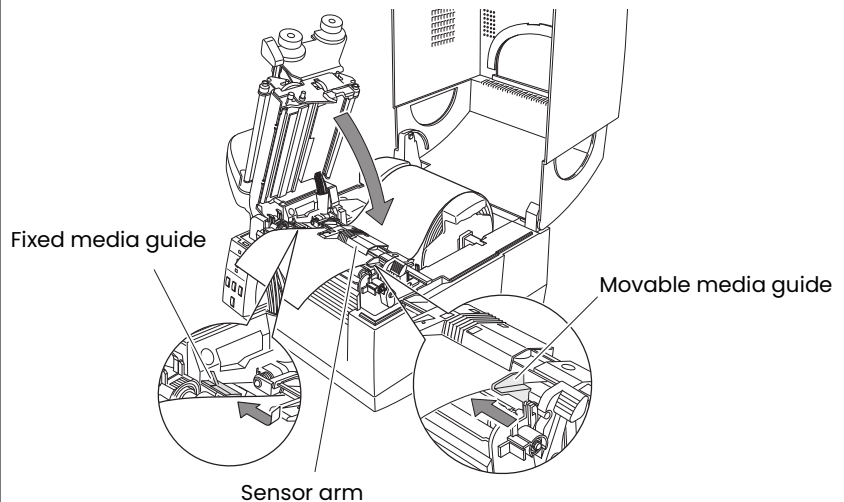

### Setting the Media

*Media*

*Thickness*

*Adjustment*

*(P.53)*

*Media Width*

*Adjustment*

*(P.54)*

9. Push the head close knob to lower and lock the head unit. Be sure to always push the head close knob to lock the head unit. Align it with the width of the media that has been set, then set the media width and media thickness adjustment dials. See "Chapter 3 Printer Adjustments".

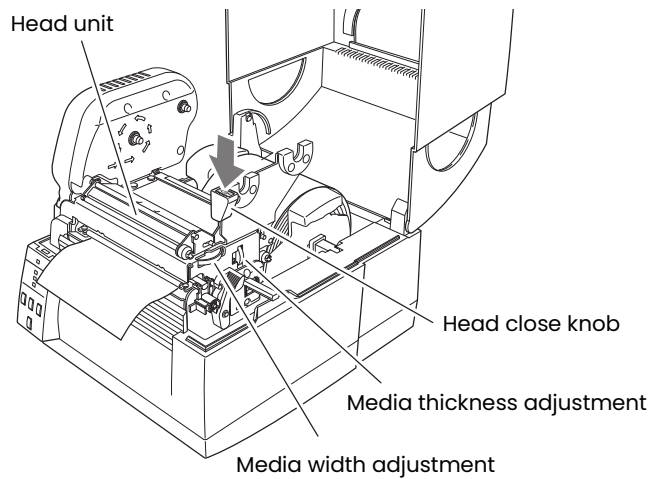

10. With the power switched on, push the FEED key to feed the media. It will halt at the next print start position.

## Setting the Media

*Setting the Paper Near End Sensor (P.32)*

### Loading fanfold media

1. Push the large blue-head open lever to release the head unit, and then lift the sensor arm by hand as shown below.

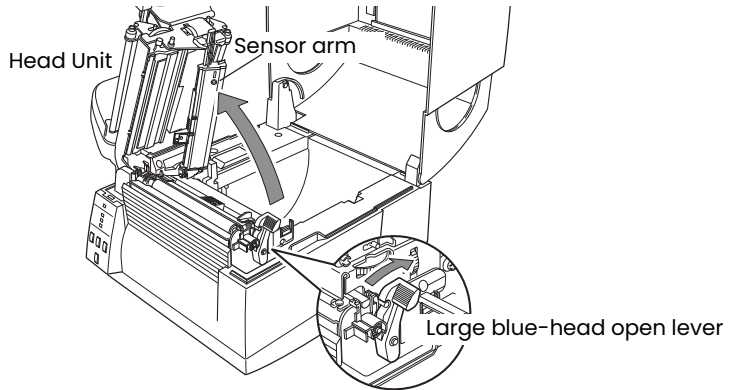

2. When using the Paper Near End Sensor, sensor position settings should be performed. See "Setting the Paper Near End Sensor" for how to perform the settings. (These settings are off when the product is shipped from the factory)
3. Insert the fanfold media through from the external media feed port at the back of the printer.
4. Leaving the specified gap from the printer, place the fanfold paper so that it is at the same height as the printer and becomes parallel with the printer as shown in the figures below.

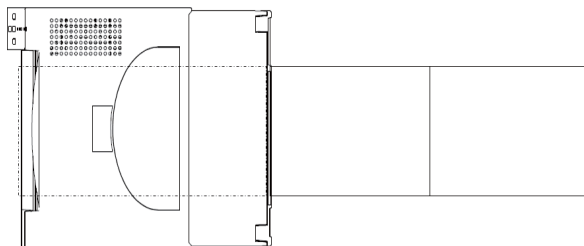
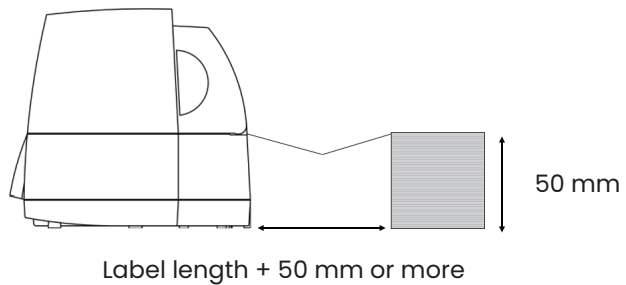

Place the fanfold media so that it is parallel with the printer.

### Setting the Media

*Quick Sensor  
Selection Method  
(P.49)*

*Adjusting the label  
detection sensor  
(Transparent sensor)  
(P.50)*

5. Insert the fanfold media through below media holder bar and set the holder by aligning it with the media width.

**Note:** Do not try to hold the media too tightly with these guides as it will cause the printer to jam during printing.

6. Select a sensor.

Ensure the POWER LED and PRINT LED are lit, then push the STOP key for at least 4 seconds while pushing the MODE/ REPEAT key.

Each time the key is pushed, the buzzer sounds and the selected sensor switches between the label detection sensor (transparent sensor), black mark detection sensor (reflective sensor) and continuous media detection sensor (reflective sensor).

When the label detection sensor (transparent sensor) is selected, the buzzer sounds once.

When the black mark detection sensor (reflective sensor) is selected, the buzzer sounds twice.

When the continuous media detection sensor (reflective sensor) is selected, the buzzer sounds thrice.

7. Setting sensor positions.

Lower the sensor arm and turn the knob, the upper sensor and bottom sensor will both move together.

**When using a label detection sensor (Transparent sensor)**

Move the upper sensor and bottom sensor close to the center of the width of the media.

When using media that is 6 inches wide, position the upper sensor and the bottom sensor all the way to the right (large blue-head open lever side).

Be careful that media with black marks does not pass the media sensor.

### Caution

The bottom sensor and upper sensor must be in alignment with each other.

### Setting the Media

*Adjusting the black mark detection sensor (Reflective sensor) (P.51)*

#### When using a black mark detection sensor (Reflective sensor)

Adjust the position of the sensor so that the black mark detection sensor (Reflective sensor) marker of the bottom sensor is at the center of the black mark of the media as shown below.

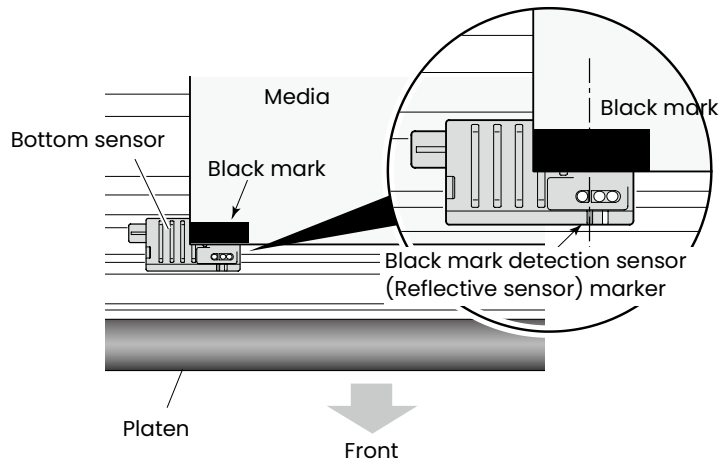

#### Caution

Do not install the upper sensor directly above the bottom sensor. Normal operation may not be possible.

*Adjusting the continuous media detection sensor (Reflective sensor) (P.52)*

#### When using the continuous media detection sensor (Reflective sensor)

Move the bottom sensor close to the center of the width of the media. Be careful that media with black marks does not pass the media sensor.

When using media that is 6 inches wide, position the bottom sensor all the way to the right (large blue-head open lever side).

#### Caution

Do not install the upper sensor directly above the bottom sensor. Normal operation may not be possible.

### Setting the Media

*Media  
Thickness  
Adjustment(  
P.53)*

*Media Width  
Adjustment  
(P.54)*

8. Lift the sensor arm up temporarily and adjust the media guide. Align the media with the fixed media guide on the left side, and then align the moveable media guide on the right side with the width of the media. Lower the sensor arm and fix the media in place.
9. Push the head close knob to lower and lock the head unit. Be sure to always push the head close knob to lock the head unit. Align it with the width of the media that has been set, then set the media width and media thickness adjustment dials. See “Chapter 3 Printer Adjustments”.
10. With the power switched on, push the FEED key to feed the media. It will halt at the next print start position.

#### **Cut position of media with a perforated line**

When tearing manually, the media can be torn at the position of the perforated line.

When adjusting the paper stop position, set the vertical printing position to a value larger than the media stop position. Otherwise, the media may come off the platen during back feeding.

Adjust each setting using the printer driver or LabelPrinterUtility.

## Setting the Media

### Setting the Paper Near End Sensor

Move the protruding part of the sensor up or down, setting in a position that matches the roll of media being used.

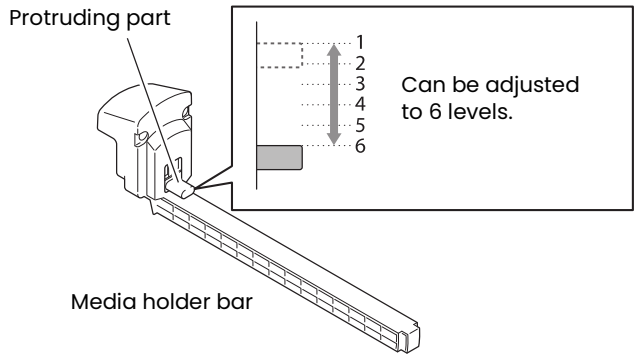

Sensor Location	Remaining roll of media
1	Approx. 8.5 mm
2	Approx. 7.5 mm
3	Approx. 6.5 mm
4	Approx. 5.5 mm
5	Approx. 4.5 mm
6	Approx. 3.5 mm

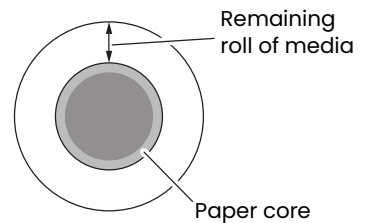

- Note:**
- These settings are off when the product is shipped from the factory.
  - The remaining roll of media (thickness of roll of media not including paper core) differs greatly according to the type of roll of media used. Use these values only as guidelines.

#### ■ When not using the Paper Near End Sensor

Disable the Paper Near End Sensor. With the protruding part of the sensor housed, push into the top section until it clicks.

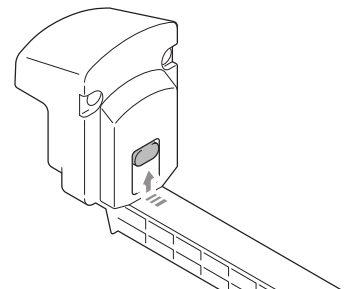

### Setting the Ribbon

The following kinds and sizes of ribbons can be used.

Types.....	Inside wound and outside wound ribbon
Max. ribbon width .....	174.0 mm (6.85 inch)
Min. ribbon width.....	50 mm (1.97 inch)
Max. ribbon length .....	360.0 m (1,181 ft)
Max. roll diameter.....	74.0 mm (2.90 inch)
Inner diameter of the paper core.....	25.4 ± 0.25 mm (1.00 ± 0.01 inch)
Outer diameter of the paper core ...	33.4 ± 0.5 mm (1.31 ± 0.02 inch)
Lead tape length.....	Less than 80.0 mm

#### Setting method

1. Check the kind of ribbon used and set the ribbon winding direction using menu setup mode or operation panel. This is the method for installing an outside wound ribbon (also known as "ink out"). Remember, the inked surface should be facing AWAY from the printhead surface!
2. Place the attached ribbon and paper core separately on one of the two attached ribbon holders. Insert the two ribbon holders into the ribbon and paper cores ensuring that they are pushed in all the way.

*Selecting the Ribbon  
Winding  
Direction(P.42, P.47)*

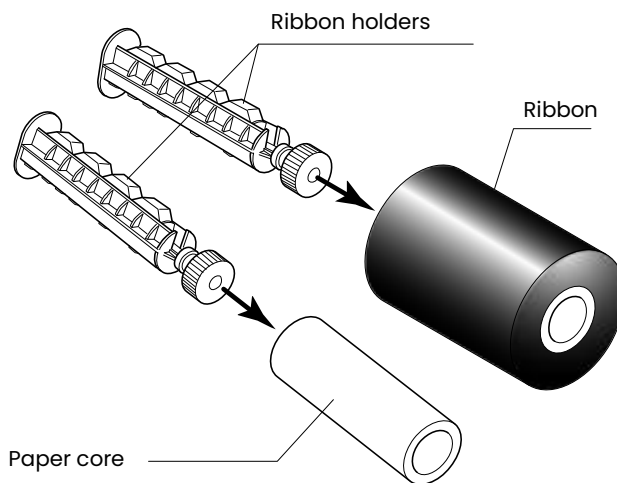

## Chapter 2 Printer Operation

### Setting the Ribbon

3. Install the unused ribbon and holder in to the rear ribbon drive unit. The splines on the ribbon drive gear mechanism engage with the end of the ribbon holder.

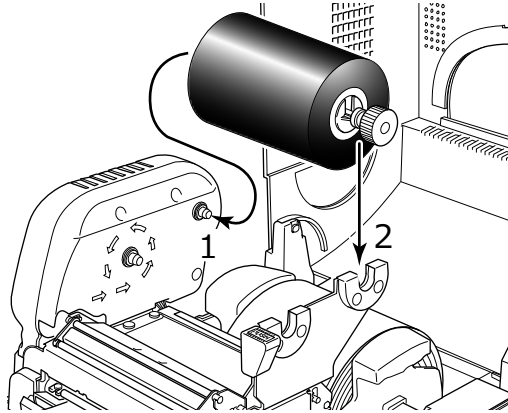

4. Push the large blue-head open lever to release the head unit. Pull out the ribbon from the bottom of the head unit to the ribbon winding side.

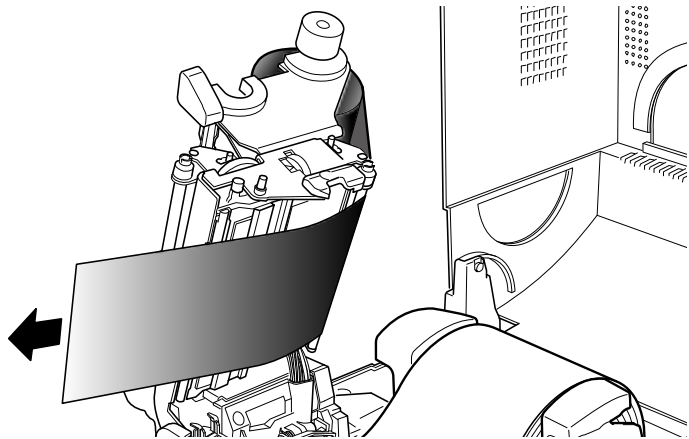

### Setting the Ribbon

5. Using the adhesive leader of the ribbon or some adhesive tape, fix the ribbon that you have pulled out on the ribbon holder on which the paper core has been set and wind it on the ribbon holder.

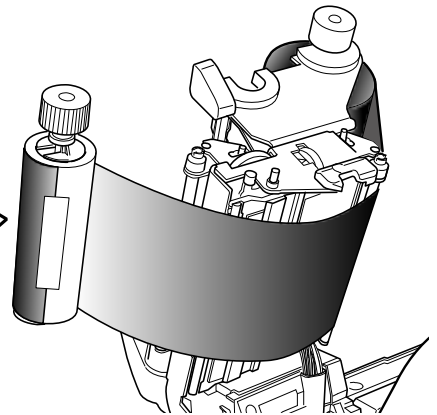
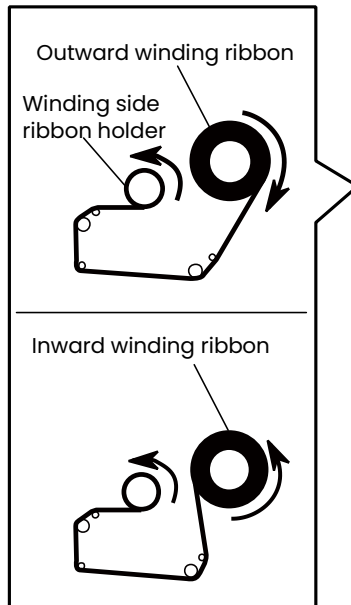

6. Set the ribbon holder on which the paper core has been set in the ribbon drive unit, then rotate it in the direction shown by the arrow to remove slack and wrinkles from the ribbon.

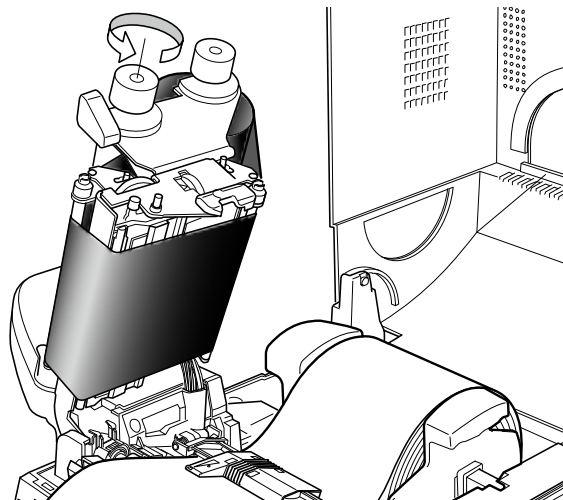

## Chapter 2 Printer Operation

### Setting the Ribbon

*Ribbon Tension  
Adjustment (P.55)*

*Ribbon Balance  
Adjustment (P.56)*

7. Push the head close knob to lower and lock the head unit. Be sure to always push the head close knob to lock the head unit. If the ribbon is wrinkled, push the FEED key until the wrinkles disappear. If the wrinkles do not disappear or if it slips, perform ribbon balance adjustment and ribbon tension adjustment. See "Chapter 3 Printer Adjustments" for these adjustment methods.

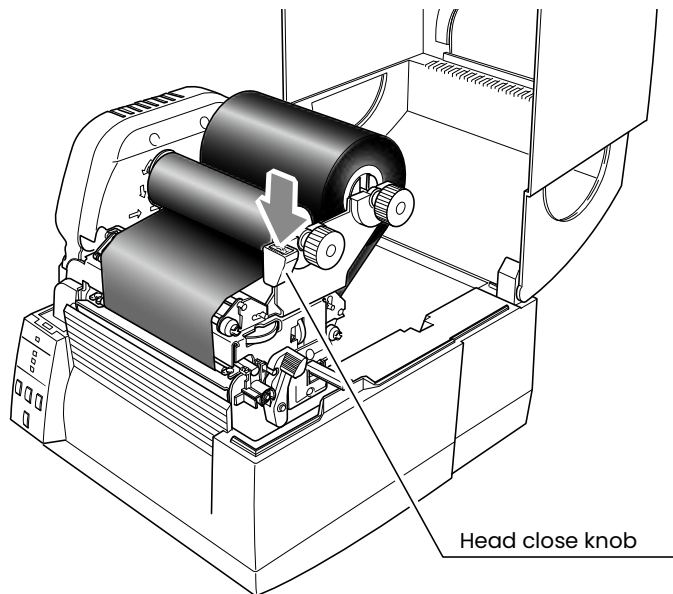

Power  
ON/OFF(P.19)

## Mode Settings

Turning on the power while pressing keys in the following combinations starts various functions.

Mode	Key operation
HEX dump mode	Turning power on while pushing the STOP key.
Self print mode	Turning power on while pushing the FEED key.
Menu setting mode	Turning power on while pushing the MODE/REPEAT key.

### HEX Dump Mode

- **When using label media**

Turn on printer power while pushing the STOP key. If the PRINT LED has begun to flash slowly, release the STOP key, and then the printer enters HEX DUMP mode.

- **When using continuous media**

Turn on printer power while pushing the STOP key. If the PRINT LED has stopped flashing slowly and begun to flash rapidly, release the STOP key, and then the printer enters HEX dump mode.

```
DUMP LIST  
  
02 40 30 31 30 30 00 02 60 30 30 32 30 0D 02 4C .M0100. c0020 .L  
44 31 31 0D 31 30 30 30 30 30 30 30 30 30 31 30 D11.100000000010  
30 30 31 30 31 32 33 34 35 36 37 38 39 3A 3B 3C 0010123456789:;<
```

*DUMP LIST*

\* To exit HEX Dump Mode, turn off the power to the printer then turn the power on again (restart).

## Mode Settings

*Setting the Media  
(P.22)*

### Self Print Mode

Performing a self test print is an easy way to check on the state of printer setting and printing quality. Install the media as explained in "Installing the Media" and then operate the printer as follows.

- **Case of label media**

Turn on printer power while pushing the FEED key. When the PRINT LED has begun to flash slowly, release the FEED key.

After it enters TEST MODE and media has fed, two labels print then printing stops.

To restart printing, press the FEED key once more.

- **Case of continuous media**

Turn on printer power while pushing the FEED key. When the PRINT LED has stopped flashing slowly and has begun to flash rapidly, release the FEED key. After it enters TEST MODE and it prints then printing stops.

To restart printing, press the FEED key once more.

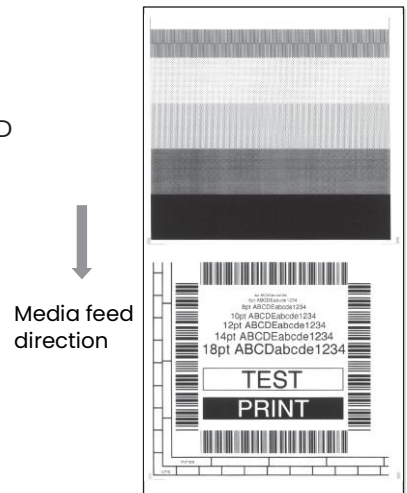

*Self print pattern*

### Media Adjustments

Using the Self Test Print shown above, you can make adjustments to the printer settings such as media width and media thickness (printhead pressure). The location of these two adjustments is explained in Chapter 3 and also shown on the labels on the printer's mechanism.

*Media Thickness  
Adjustment (P.53)*

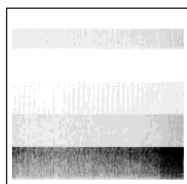

The first sample, left, shows an incorrectly set "media thickness adjustment". For standard label media, it is recommended you set the blue dial to the "0" position.

*Media Width  
Adjustment (P.54)*

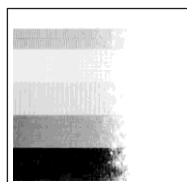

The second sample, left, shows an incorrectly set "media width adjustment". For 6-inch or 150mm wide media, the adjuster should be set to the "9" position on the blue dial. The settings shown above are for general label media and may not apply to specialist media.

### Mode Settings

#### Menu Setup Mode

If the printer power is turned on while the MODE/REPEAT key is pressed, the printer enters menu setup mode. In this mode, the printer's configuration can be changed using the VuePrint Menu System. During menu setting mode, the PRINT LED and CONDITION LED are on. Media must be installed in the printer to use the VuePrint menu system.

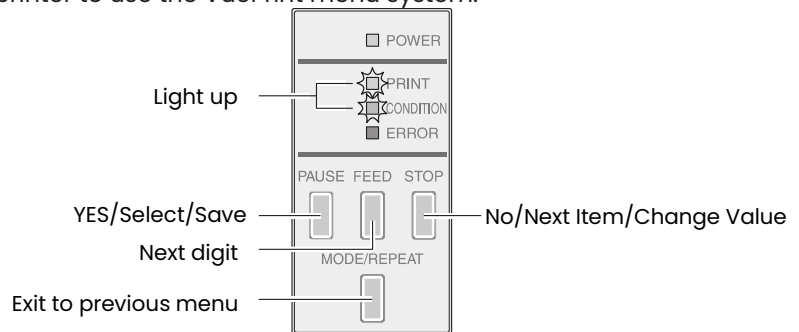

#### Functions of the keys

After each menu item is printed, the printer will also print the function of each of the buttons at that time. They vary slightly depending on the menu selected but generally fit the following guidelines:

##### **PAUSE key (YES/Select/Save):**

It is pushed to either select the current menu option or to save the new setting after which it advances to the next menu.

##### **STOP key (NO/Next Item/Change Value):**

Whilst changing a menu value (such as head temperature), pressing this key displays the next menu value available but does not save the setting.

In the "main menu", pressing this key moves to the next menu available.

##### **FEED key (Next digit):**

With some menu options such as head temperature, there is more than one "digit" than can be changed.

This key moves the cursor to the next digit.

##### **MODE/REPEAT key (Exit to previous menu):**

Exits the current menu or the VuePrint menu system.

### **Caution**

When you are changing a menu value, pressing the "PAUSE" key (YES) causes the printer to save the currently selected parameter. The CONDITION LED flashes briefly. Do not turn off the power to the printer at this time as this may cause a malfunction. If the power is accidentally turned off, first reset the printer to factory defaults.

Mode Settings

Menu Setting Flow Chart

The following is a flow chart showing the CL-S6621/CL-S6631 VuePrint menu system.

Menu Setup  
Mode(P.39)

Printing during top  
menu setting  
(P.40)

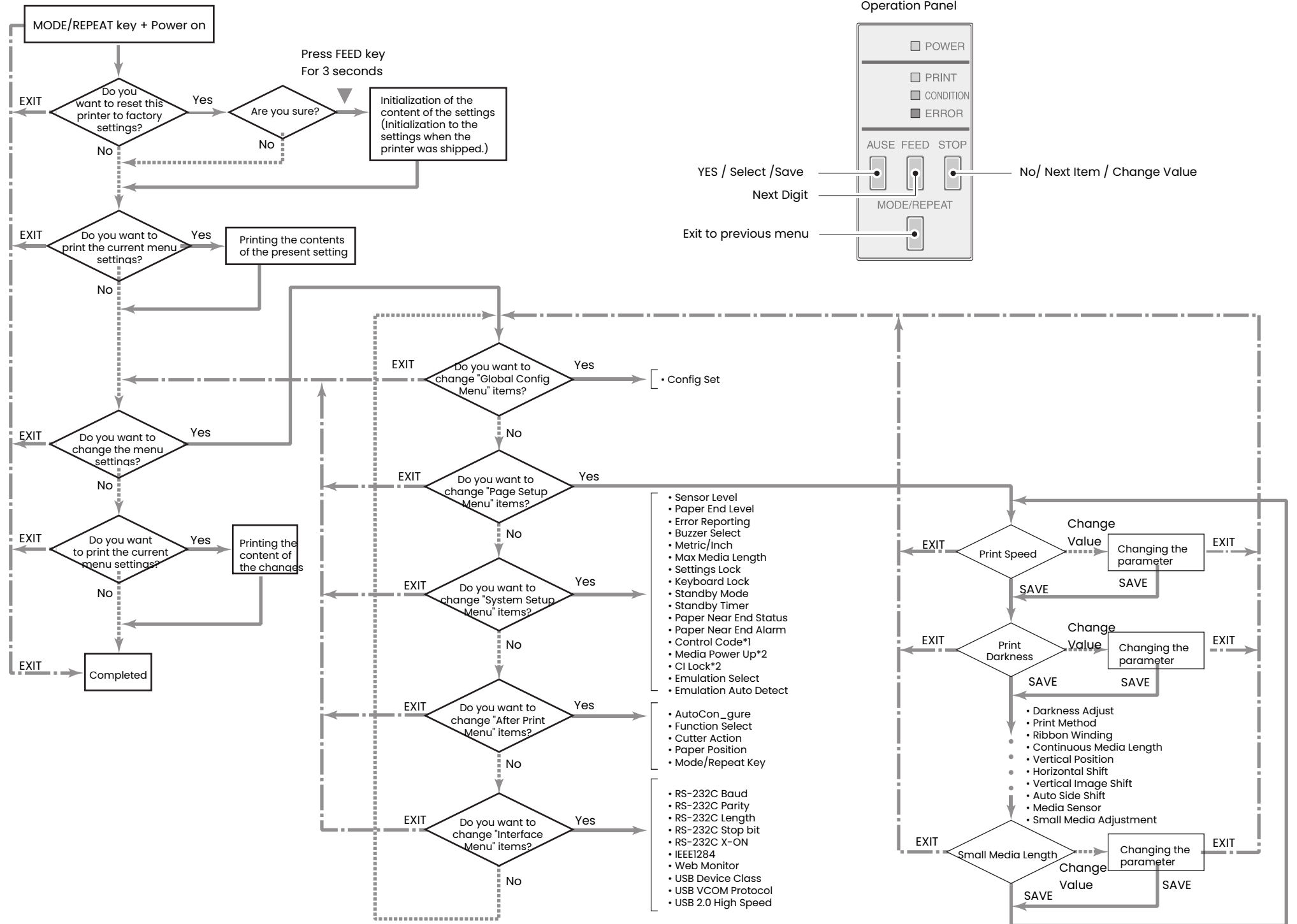

\*1 Only when Datamax emulation is selected  
 \*2 Only when Zebra® emulation is selected

# Chapter 2 Printer Operation

## Mode Settings

Menu Setting Flow Chart(P.40)

This particular example is changing the print speed and print darkness then continues through the remainder of the "Print Setup" menu.

The actual output from the printer is "vertically reversed" due to the way the printer outputs the menu options. Please look at the example below to see how the output changes.

### Printing during top menu setting

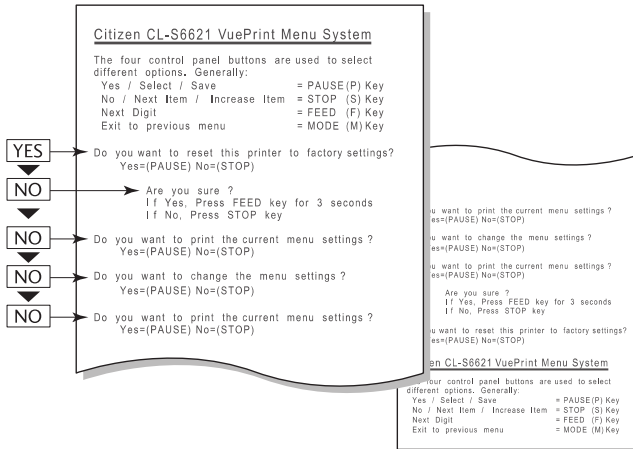

<Example of CL-S6621 Datamax emulation selected>

Menu Setting Flow Chart(P.40)

### Printing during sub menu setting

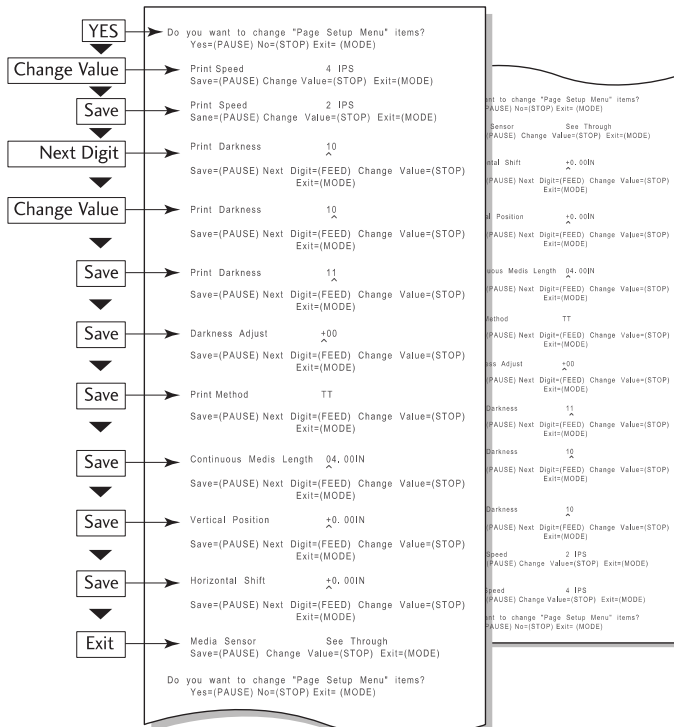

<Example of CL-S6621 Datamax emulation selected>

# Chapter 2 Printer Operation

## Mode Settings

Menu Setting Flow  
Chart(P.40)

### Printing of contents of settings

Machine Information	
Model Number	: CL-S6621
Boot Version	: X.X
ROM Version	: XXXXXXXX
ROM Date (DD//MM//YY)	: XX/XX/XX
ROM Check Sum	: XXXX
FPGA Version	: XXXXXXXX
Head Check	: OK
*1 Print Counter	: 0000.872 km
*1 Service Counter	: 0000.872 km
Cut Counter	: 83
Sensor Monitor	: 2.56 V
Option Interface	: None
Current Menu Setting	
[Global Config Menu]	
Config Set	: 1
[Page Setup Menu]	
Print Speed	: 6 IPS
Print Darkness	: 10
Darkness Adjust	: 00
Print Method	: Thermal Transfer
Ribbon Winding	: Outside
Continuous Media Length	: 4.00 inch
Vertical Position	: 0.00 inch
Auto Side Shift	: 0 dot
Horizontal Shift	: 0.00 inch
Vertical Image Shift	: 0.00 inch
Media Sensor	: See Through
Small Media Adjustment	: Off
Small Media Length	: 1.00 inch
*2 Symbol Set	: PM
[System Setup Menu]	
Sensor Level	: 1.7 V
Paper End Level	: 2.80 V
Error Reporting	: On Printing
Buzzer Select	: On
Metric/Inch	: Inch
Max Media Length	: 10.00 inch
Settings Lock	: Off
Keyboard Lock	: Off
Standby Mode	: Off
Standby Timer	: 5 min
Paper Near End Status	: On
Paper Near End Alarm	: Off
Control Code	: STD
Emulation Select	: DM4
Emulation Auto Detect	: Full Auto
[After Print Menu]	
AutoConfigure	: On
Function Select	: Tear
Cutter Action	: Backfeed
Paper Position	: 0.00 inch
Mode/Repeat Key	: Disabled
[Interface Menu]	
RS-232C Baud rate	: 9600 bps
RS-232C Parity	: None
RS-232C Length	: 8 bit
RS-232C Stop bit	: 1 bit
RS-232C X-ON	: Yes
IEEE 1284	: On
USB Device Class	: Printer
USB VCOM Protocol	: Auto
USB 2.0 High Speed	: On

<Example of CL-S6621 Datamax emulation selected>

\*1 If the double heat function is enabled, the value doubles. This function reduces print fading. To enable this function, configure the setting via Windows driver properties or LabelPrinterUtility. See the respective manual for how to configure the setting.

\*2 The settings of the Symbol Set can be changed only by a command.

**Note:** Citizen continually enhances its printers with new options and settings based on our customer's requests. Extra or changed menu items may appear on the above print out in some case.

## Chapter 2 Printer Operation

### Mode Settings

#### Menu Setting Table

**Global Config menu** - allows you to switch between 3 complete 'config sets' contained within the printer.

**Page Setup Menu** - allows you to change settings related to the media or print quality.

**System Setup Menu** - allows you to change settings for the printer hardware and basic control systems.

**After Print Menu** - changes how the printer reacts after the label has been printed.

**Interfaces** - changes interface parameters such as baud rate.

#### Menu Setting

Top Menu	Sub Menu	Default	Menu	Remarks
Global Configuration	-	Config Set 1	Config Set 1 Config Set 2 Config Set 3	Sets the Config Set.
Page Setup	Print Speed	6 IPS	2 to 6 IPS	[For CL-S6621] Printing speed setting.
		4 IPS	2 to 4 IPS	[For CL-S6631] Printing speed setting.
	Print Darkness	10	00 to 30	Print darkness setting (printhead temperature)
	Darkness Adjust	0	-10 to 10	Darkness command adjustment
	Print Method	Thermal transfer	Thermal transfer Direct thermal	Selecting thermal transfer (ribbon)/direct thermal media
	Ribbon Winding	Outside	Outside Inside	Selecting the ribbon winding direction.
	Continuous Media Length	4.00 inch	0.25 to 99.99 inch	Setting media length of continuous media. Lower level = during mm mode.
		101.6 mm	6.40 to 2539.7 mm	
	Vertical Position	0.00 inch 0.0 mm	-1.00 to 1.00 inch -25.4 to 25.4 mm	Print start position adjustment
	Horizontal Shift	0.00 inch 0.0 mm	-1.00 to 1.00 inch -25.4 to 25.4 mm	Horizontal printing location adjustment
	Vertical Image Shift	0.00 inch	0.00 to 32.00 inch	Adjust the off set value in vertical when mapping data on a RAM. (Datamax)
		0.0 mm	0.0 to 812.8 mm	
			000 dots	Adjust the off set value in vertical when mapping data on a RAM. (Zebra®/Eltron®)
	Auto Side Shift	00 dots	00 to 15 dots	Allows horizontal shifting of printing position by specified number of dots per page. Effective when load is applied to a specific head area, like vertical lines.
Media Sensor	See Through	See Through Reflect None	Label sensor selection	
Small Media Adjustment	Off	On Off	Setting for small labels	
Small Media Length	1.00 inch	0.25 to 1.00 inch	Setting length of small label media	
	25.4 mm	6.40 to 25.4 mm		
Symbol Set	PM	50 symbols	Setting symbol set.	
System Setup	Sensor Level	1.7 V	0.0 V to 3.3 V	Setting the threshold of the sensor
	Paper End Level	3.00 V	0.01 to 3.00 V	Sets the paper end level.
	Error Reporting	On Printing	On Printing Immediate	Setting for error report.
	Buzzer Select	On	On Off	Setting buzzer sounding conditions

## Chapter 2 Printer Operation

### Mode Settings

Top Menu	Sub Menu	Default	Menu	Remarks
	Metric/Inch	Inch	Inch mm	Setting the units used
	Max Media Length	10.00 inch 254.0 mm	1.00 to 99.99 inch 25.4 to 2539.7 mm	Setting the maximum label length.
	Settings Lock	Off	On Off	When on, prevents software commands from changing the values set by the VuePrint menu
	Keyboard Lock	Off	On Off	Prevents the control panel from affecting the printer's configuration. (User "lock-out")
	Standby Mode	Off	On Off	Choose the Standby Mode. If you switch on the Standby Mode, the printer will go into power-saving mode after the elapse of the time set by the Standby Timer.
	Standby Timer	5 min	1 to 99 min	You can set the time it takes for the machine to go into Standby Mode.
	Paper Near End Status	On	On Off	Settings for whether or not paper near end status will be reflected in status.
	Paper Near End Alarm	Off	On Off	Settings for whether or not LED display will be used to display paper near end.
	Control Code	STD	STD ALT ALT-2	Switches command mode of DMX mode. (only when Datamax emulation is selected)
	Media Power Up	Off	On Off	Selects whether or not to initiate media measurement when the power is ON. (only when Zebra® emulation mode is selected on international models)
	CI Lock	Off	On Off	Activates/deactivates the CI command. (only when Zebra® emulation mode is selected on international models)
	Emulation Select	DM4 (Datamax) ZPI2 (Zebra®)	DM4 DMI DPP ZPI2 EPI2	Datamax/Zebra® compatibility selection DM4 DataMax 400 DMI DataMax IClass DPP DataMax Prodigy Plus ZPI2 Zebra® ZPL2™ EPI2 Zebra® EPL2™
	Emulation Auto Detect	Full Auto	On Off Full Auto	Selects the detection of Datamax and Zebra® emulation.
<b>After Print</b>	AutoConfigure	On	On Off	Optional auto configure On...Auto configure effective. If a peeler unit or auto-cutter is installed, each mode is automatically set regardless of the "function select" setting. Off...Auto configure ineffective. When a peeler unit or auto-cutter is installed but has not been started, it is off and the operation is selected by "Function select".

## Chapter 2 Printer Operation

### Mode Settings

Top Menu	Sub Menu	Default	Menu	Remarks
	Function Select	Tear	Off Tear Peel On* Cut On*	Selects the type of options installed and adjusts the "paper stop" position accordingly. For example, the position where the label stops in "Tear" mode is different to that in "Peel On" mode.
	Cutter Action*	Backfeed	Backfeed Through	Cutter operating method setting Backfeed: it feeds back after each cutting operation. Through: when the number copied = n, the back end of sheet 1 to n-1 passes through, and the back end of the final page that is a single sheet is copied and fed back.
	Paper Position	0.00 inch 0.0 mm	Peel/Cut/Tear Off (Printing start position (platen-centered)) 0.00 to 2.00 inch 0.0 to 50.8 mm Peel/Cut/Tear On (Tear position/Peel On position/Cut On position) -1.00 to 1.00 inch -25.4 to 25.4 mm	Adjusts the stop position. It is based on the inch/millimeter setting. There are initial values of the stop position for each device set by "Function Select", and later, relative values are set.
	Mode/Repeat Key	Disabled	LabelSet LastOne Disabled	Repeat method selection LabelSet: Reissues multiple labels. This setting is ignored when Zebra® emulation mode is selected. LastOne: Issues only the final page. In count case, it issues only 1 label while continuing. Disabled: Makes the repeat key invalid.
<b>Interface</b>	RS-232C Baud	9600	115200 57600 38400 19200 9600 4800 2400	Sets the baud rate of the serial interface. • Interface related settings are effective after the power is turned on again.
	RS-232C Parity	None	None Odd Even	Sets the communication parity of the serial interface.
	RS-232C Length	8 bits	8 bits 7 bits	Sets the character length of the serial interface.
	RS-232C Stop bit	1 bit	1 bit 2 bits	Sets the stop bit of the serial interface.
	RS-232C X-ON	Yes	Yes No	Selects the X-ON flow control of the serial interface.

\* Effective only when the optional unit is attached.

## Chapter 2 Printer Operation

### Mode Settings

Top Menu	Sub Menu	Default	Menu	Remarks
	IEEE1284	On	On Off	Enable or disables the 'enhanced' features of the IEEE1284 parallel interface.
	USB Device Class	Printer	Printer VCOM	Selects the USB device class.
	USB VCOM Protocol	Auto	Auto DTR X-ON	Selects the protocol (flow control) when operating USB VCOM.
	USB 2.0 High Speed	On	On Off	Settings for enabling / disabling USB 2.0 High Speed.
<b>Option Interfaces*1</b>	Web Monitor	Auto	Auto On Off	Selecting the web monitor function.
	Network Address	-	0.0.0.0 to 255.255.255.255	Setting fixed IP address of the LAN board.
	Subnet Mask	-	0.0.0.0 to 255.255.255.255	Setting fixed subnet mask value of the LAN board.
	Gateway Address	-	0.0.0.0 to 255.255.255.255	Setting fixed default gateway address of the LAN board.
	BOOTP	-	On Off	Setting the BOOTP of the LAN board.
	DHCP	-	On Off	Setting the DHCP of the LAN board.
<b>Machine Information</b>	Model Number	-	CL-S6621 CL-S6631	[For CL-S6621] Displays the model name [For CL-S6631] Displays the model name
	Serial Number	-	JS*****	Displays the serial number
	Boot Version	-	*.*	Displays the boot version
	ROM Version	-	*****	Displays the ROM version
	ROM Date	-	**/**/**	Displays the ROM creation date
	ROM CheckSum	-	****	Displays the ROM checksum
	FPGA Version	-	*.*	Displays the FPGA version
	Head Check	-	OK NG	Displays whether the resistance value of the head is within the specification range
	Print Counter*2	-	****.* km	Displays the print counter
	Service Counter*2	-	****.* km	Displays the service counter
	Cut Counter	-	*****	Displays the cut counter only for models with cutters
	Sensor Monitor	-	*.* V	Displays the sensor level

\*1 If the multi-function LAN board (IF1-ES04) is mounted.

\*2 If the double heat function is enabled, the value doubles. This function reduces print fading. To enable this function, configure the setting via Windows driver properties or LabelPrinterUtility. See the respective manual for how to configure the setting.

Menu Setup  
Mode(P.39)

## Quick Setup of the Print Method

The print method (thermal transfer method/direct thermal method) can be set using operation panel in addition to menu setting mode.

### Caution

Be sure to always shut off the operation of print before changing a setting. You cannot change a setting during printing (including pause).

### Setting method

Each time you push the PAUSE key while pushing the MODE/REPEAT key, a buzzer sounds and the printer switches between thermal transfer method and direct thermal method.



- If thermal transfer method has been selected, the buzzer sounds once and the CONDITION LED flashes.  
If direct thermal method has been selected, the buzzer sounds twice and the CONDITION LED flashes.  
The change is complete when the CONDITION LED goes out. Changes will remain in effect even after the power is turned off.

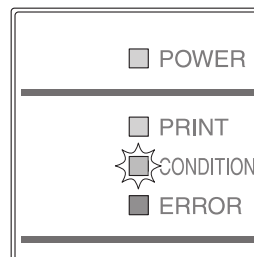

### Selecting the Ribbon Winding Direction

Besides the Menu Setup Mode, you can also select the ribbon winding direction (outside-wound / inside-wound) by using the keys on the Operation Panel.

Outside-wound and inside-wound will switch from one to another each time you press the PAUSE key for 4 seconds or more while pressing the MODE/REPEAT key when not printing.

- If the outside-wound (also known as “ink out”) gets selected, the buzzer will sound 3 times, and CONDITION LED will flash.
- If the inside-wound (also known as “ink in”) gets selected, the buzzer will sound 4 times, and CONDITION LED will flash.

When the lights go out on the CONDITION LED, selection is finalized. Changes will remain in effect even after the power is turned off.

**Note:** The winding direction cannot be changed when printing.

### Emulation Auto Detect: Cross-Emulation™

If a control language different from the emulation when operating with the Emulation Auto Detect setting in System Setup set to “On” or “Full Auto” is received, the emulation is automatically switched. Note that the Eltron® language will not be detected.

- **When the Emulation Auto Detect setting is set to “On”**  
If the “Emulation Auto-Detect” is set to “On”, this will cause the CONDITION LED to flash when it detects an alternative emulation. By selecting MODE/REPEAT KEY, the printer will restart and emulation will automatically make a switch. By selecting another KEY, detection will be canceled, and CONDITION LED will turn Off.
- **When the Emulation Auto Detect setting is set to “Full Auto”**  
During startup, the saved emulation is started by Emulation Select. Then, operation is continued with the emulation of the initially-received control language. New emulations are saved to the Emulation Select setting. At this time, automatic restart is not carried out.  
If the printer is manually restarted later on, it will start up with the newly saved emulation setting. When a different control language is received without restarting, the emulation of the last received control language is saved in the command settings, and automatic restart is carried out. Note that the data received before restarting is ignored.

*Menu Setting Table  
(P.42)*

*Menu Setting Table  
(P.42)*

### Manually Selecting the Printer Emulation

To manually choose between Datamax, Zebra® and Eltron® emulations, you can use the VuePrint menu system. The Emulation Select option in the System Setup menu allows you to do this.

Alternatively, you can use the “Quick Switch” option as follows:

1. Turn on the printer holding down PAUSE and FEED keys together.  
After the printer beeps three times and the CONDITION LED flashes, release the PAUSE and FEED keys.
2. Press FEED key once for Datamax emulation.
3. Press FEED key two times for Zebra® emulation.
4. Press FEED key three times for Eltron® emulation. The printer beeps each time the feed key is pressed.
5. To save the new selection, press MODE/REPEAT key. The printer will beep four times and then restarts.

# Chapter 3 Printer Adjustments

## Sensor Adjustments

The sensing level of the label detection sensor (transparent sensor), black mark detection sensor (reflective sensor), and continuous media detection sensor (reflective sensor) are adjusted separately and independently. Firstly, the sensor type must be selected either using the VuePrint menu system or the Sensor Method Selection shown below.

Then the adjustment and calibration of the sensor can be made.

### Entering Sensor Adjustment Mode

1. Turn on the power while pushing the PAUSE key, FEED key, and STOP key simultaneously.

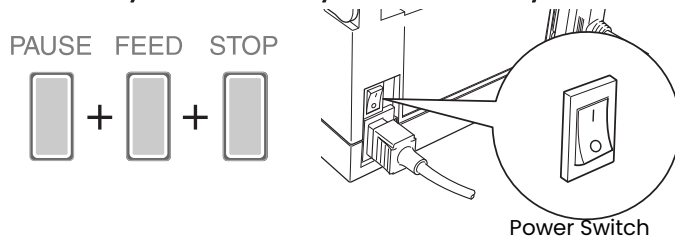

2. After the PRINT LED and CONDITION LED light up, release the keys to change the printer to sensor adjustment setting mode.

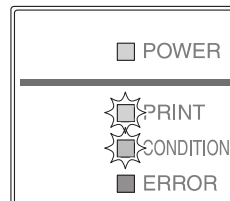

### Quick Sensor Selection Method

To select the sensor, ensure the CONDITION LED is lit, then push the STOP key while pushing the MODE/REPEAT key.

Each time the key is pushed, the buzzer sounds and the selected sensor alternates between the transparent sensor and reflective sensor. If the keys are pushed for at least 4 seconds, the selected sensor switches to the continuous media detection sensor (reflective sensor).

When the label detection sensor (transparent sensor) is selected, the buzzer sounds once and the PRINT LED lights up.

When the black mark detection sensor (reflective sensor) is selected, the buzzer sounds twice and the PRINT LED flashes.

When the continuous media detection sensor (reflective sensor) is selected, the buzzer sounds thrice and the PRINT LED goes off.

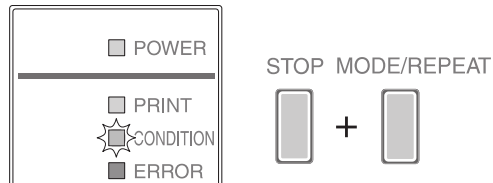

*Loading roll media (P.51)*

### Sensor Adjustments

*Loading roll  
media(P.23)*

*Quick Sensor Selection  
Method (P.49)*

### Adjusting the label detection sensor (Transparent sensor)

1. Select the label detection sensor (Transparent sensor), and open the sensor arm.
2. Install only the liner media (label backing paper) with the label media removed so that it will pass between the platen roller and the media sensor. (Be careful that media with black marks does not pass the media sensor.) Then close the sensor arm and the printhead.

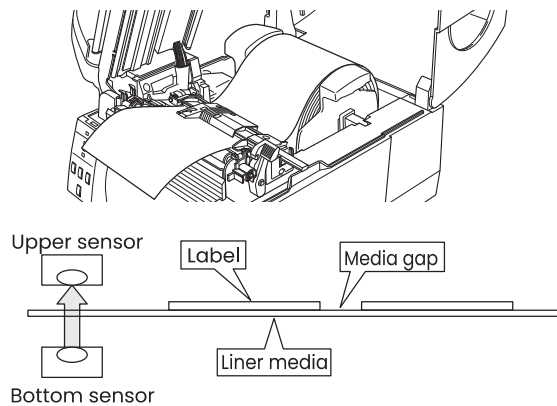

### Caution

The bottom sensor and upper sensor must be in alignment with each other.

3. If the PAUSE key is pressed and released while the MODE/ REPEAT key is pressed, the PRINT LED goes off, after the CONDITION LED switches from lit to flashing, media feeding starts, and the sensor is automatically adjusted.
4. If automatic adjustment stops normally, the PRINT LED and CONDITION LED return to their original status. If it stops abnormally (adjustment impossible), the CONDITION LED and ERROR LED flash.
5. To save the setting, push the STOP key. The buzzer sounds once and the printer restarts.

### Sensor Adjustments

*Quick Sensor Selection  
Method (P.49)*

#### Adjusting the black mark detection sensor (Reflective sensor)

1. Select the black mark detection sensor (Reflective sensor).
2. With the black mark detection sensor (Reflective sensor) selected, install the label media so that it is between the platen roller and the media sensor. (Be careful that black mark and media gap do not pass the media sensor.) Then close the sensor arm and the printhead.

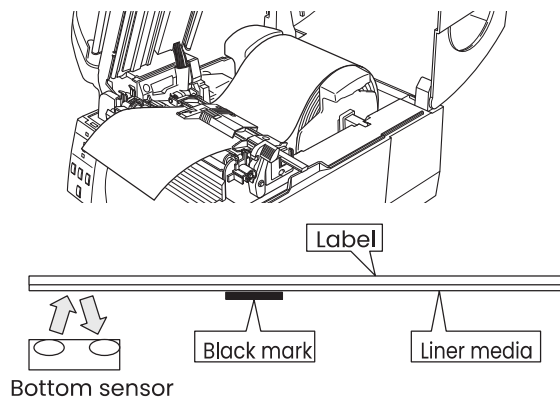

#### **Caution**

Do not install the upper sensor directly above the bottom sensor. Normal operation may not be possible.

3. If the PAUSE key is pressed and released while the MODE/ REPEAT key is pressed, the PRINT LED goes off, after the CONDITION LED switches from lit to flashing, media feeding starts, and the sensor is automatically adjusted.
4. If automatic adjustment stops normally, the PRINT LED and CONDITION LED return to their original status. If it does not stop normally (adjustment impossible), the CONDITION LED and ERROR LED flash.
5. To save the setting, push the STOP key.  
The buzzer sounds once and the printer restarts.

### Sensor Adjustments

*Quick Sensor Selection  
Method (P.49)*

#### Adjusting the continuous media detection sensor (Reflective sensor)

1. Select the continuous media detection sensor (reflective sensor), and open the sensor arm.
2. Install the label media so that it is between the platen roller and the media sensor.  
(Be careful that media with black marks does not pass the media sensor.)  
Then close the sensor arm and the printhead.

 **Caution**

Do not install the upper sensor directly above the bottom sensor. Normal operation may not be possible.

3. If the PAUSE key is pressed and released while the MODE/ REPEAT key is pressed, after the CONDITION LED switches from lit to flashing, media feeding starts, and the sensor is automatically adjusted.
4. If automatic adjustment stops normally, the CONDITION LED return to its original status.  
If it stops abnormally (adjustment impossible), the CONDITION LED and ERROR LED flash.
5. To save the setting, push the STOP key.  
The buzzer sounds once and the printer restarts.

*Loading roll media(P.23)*

*Self Print Mode(P.38)*

### Media Thickness Adjustment

It may be necessary to adjust the printer according to the thickness of the media being used. This can be done easily by rotating the media adjustment dial to improve the print quality.

- Poor print quality across the complete printout means wrongly set media thickness. See this section.
- Poor print quality on one side of a printout means wrongly set media width. See next section.

#### When using standard label media, high quality media or direct thermal media

Adjust while performing test printing by turning the dial from the smallest number on the dial to the largest number on the dial one step at a time.

#### When using thicker media (tags, card, etc.)

Adjust while performing test printing by turning the dial from the smallest number on the dial to the largest number on the dial one step at a time.

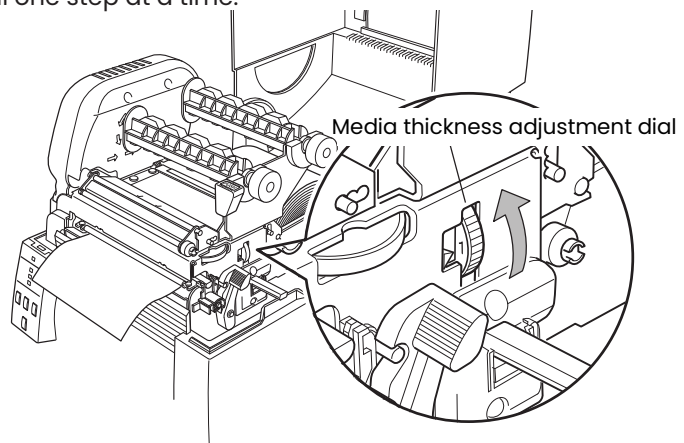

Media Thickness Dial Position	Suggested media type
0	Direct thermal media (thin media)
1-2	Standard Label media, Direct thermal media
3-5	Thicker backing paper labels
6-9	Cards, tags, thicker media stock.

These values are guidelines.

The exact media being used must be matched with the correct media thickness adjustment position.

- When shipped from the factory, it is set at dial 1 or 2. (The factory default setting is indicated on the adjustment gauge label.)
- The offset adjustment varies according to the thickness and the hardness of the media.
- The dial may also need to be adjusted in accordance with density of print and the occurrence of wrinkles in the ribbon.

*Loading roll media(P.23)*

*Self Print Mode(P.38)*

## Media Width Adjustment

The head pressure varies according to the width of the media being printed. The head pressure balance must be adjusted according to media width so that constant head pressure is applied to the head. With this printer, it can be adjusted easily by turning the media width adjustment dial.

If the printing is blurred or lightly printed on one side or the media moves in a zigzag pattern adjust the head pressure balance.

After making an adjustment, confirm the output quality with a test print.

### Caution

When using narrow media, be sure to MAKE this adjustment. (If you do not, the head may be damaged by jamming, etc.)

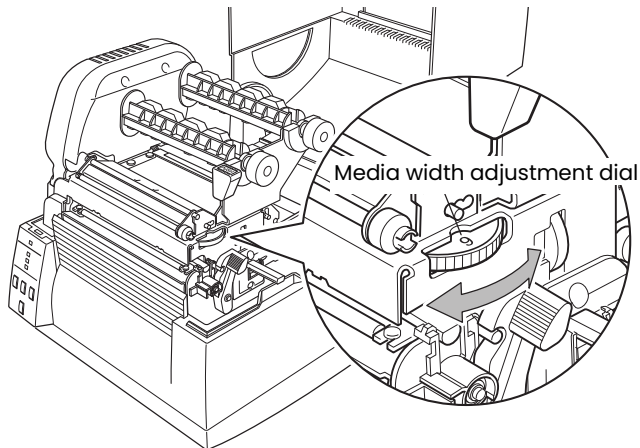

Dial position	Media width mm (inches)	Head pressure
0	50.0 to 62.0 mm (1.97 to 2.44)	Low  High
1	62.0 to 76.0 mm (2.44 to 2.99)	
2	76.0 to 88.0 mm (2.99 to 3.46)	
3	88.0 to 99.0 mm (3.46 to 3.90)	
4	99.0 to 108.0 mm (3.90 to 4.25)	
5	108.0 to 118.0 mm (4.25 to 4.65)	
6	118.0 to 133.0 mm (4.65 to 5.24)	
7	133.0 to 148.0 mm (5.24 to 5.83)	
8	148.0 to 163.0 mm (5.83 to 6.42)	
9	163.0 to 178.0 mm (6.42 to 7.01) (setting when shipped)	

These values are guidelines.

- The dial may also need to be adjusted in accordance with density of print and the occurrence of wrinkles in the ribbon.

*Setting the Ribbon(P.33)*

## Adjusting the Ribbon

When using narrow-width ribbons or very specialist thermal ribbon material, it may be necessary to adjust the ribbon tension and ribbon balance adjustments to avoid ribbon wrinkle or slippage.

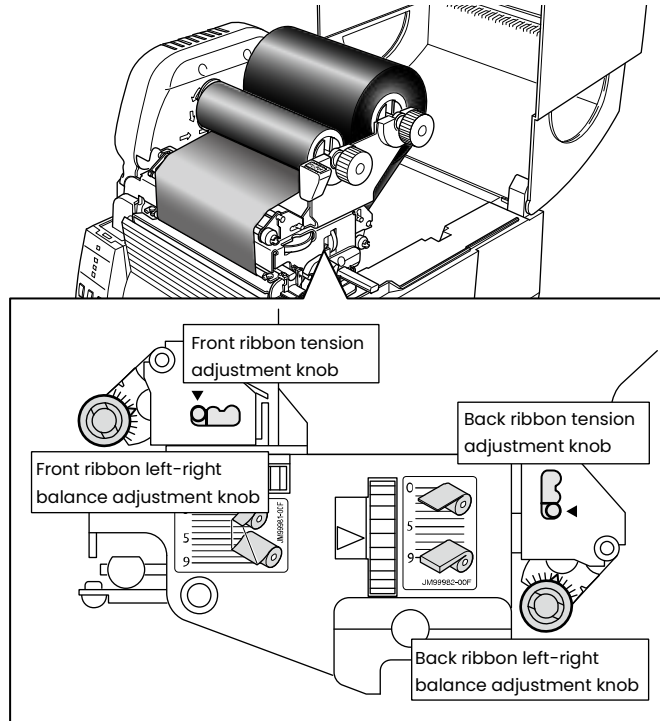

### Ribbon Tension Adjustment

The ribbon tension has three adjustment positions on both the feeding side (back side) and winding side (front side).

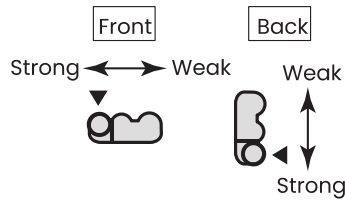

#### Adjustment criteria

- Ribbon width of 6 inches: strong
- Ribbon width of 4 inches: medium
- Ribbon width of 2 inches: weak

*Self Print Mode(P.38)*

First make a test print and then adjust the printer as required:

- Slippage of the ribbon causes a dirty film to be seen on the media. Reduce the tension adjusters
- Ribbon wrinkle (diagonal lines across printout): Increase the ribbon tension.

After making any adjustments, print another test print or two to make sure the ribbon is feeding correctly.

## Adjusting the Ribbon

### Ribbon Balance Adjustment

Do this adjustment by turning the front and back balance adjustment knobs. If the ribbon is wrinkled, adjust it as follows. The scale is usually aligned with the center.

#### Adjustment procedure

1. Check between the supply side ribbon and the back balance adjustment knob to find out on which side the ribbon is loose.

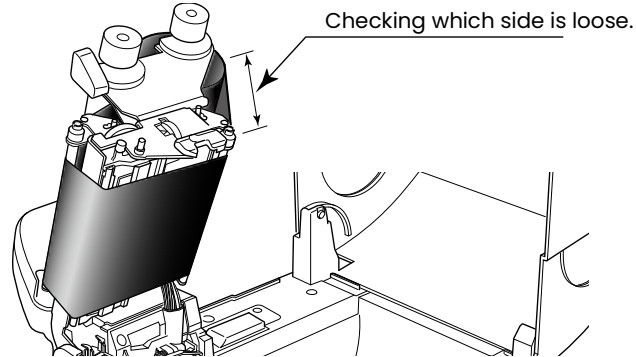

#### ■ Case of looseness on the side opposite the adjustment knob

2. Turn the front adjustment knob to the right to remove the looseness, then make a test print to ensure that the ribbon is not wrinkled.

If it is wrinkled, turn the back adjustment knob to the right and do the test printing again and check to make sure that the ribbon is not wrinkled.

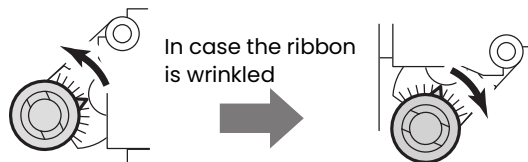

Front balance adjustment knob    Back balance adjustment knob

#### ■ Case of looseness on the adjustment knob side

3. Turn the front adjustment knob to the left to remove the looseness, then make a test print to ensure that the ribbon is not wrinkled.

If it is wrinkled, turn the back adjustment knob to the left and do the test printing again and check to make sure that the ribbon is not wrinkled.

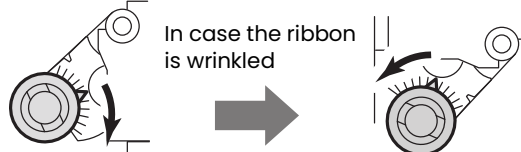

Front balance adjustment knob    Back balance adjustment knob

**Note:** Wrinkles may occur in the ribbon if the media thickness adjustment dial and media width adjustment dial are not adjusted correctly. If wrinkles occur even when the ribbon is adjusted, adjust these dials as well.

*Media Thickness  
Adjustment (P.53)*

*Media Width  
Adjustment (P.54)*

### Cleaning

Wipe off any foreign matter such as media dust, dirt and adhesive substances built up around the printhead with the head cleaning pen (head cleaner) provided, and use a soft cloth soaked in ethyl alcohol for the platen etc.

It is particularly important to clean the thermal printhead after printing on thermal media for long periods, which will guarantee the print quality and extend the life of the thermal printhead.

**Note:** Always use the head cleaner when cleaning the thermal printhead.

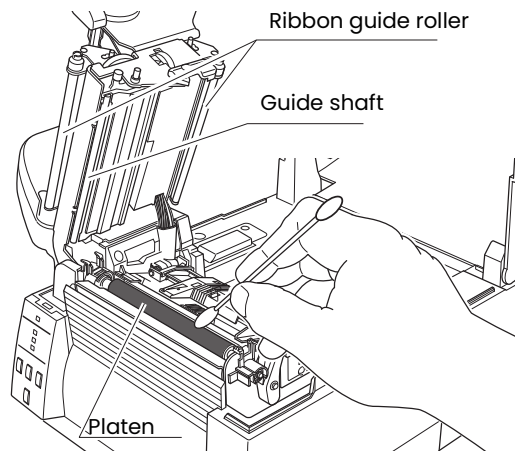
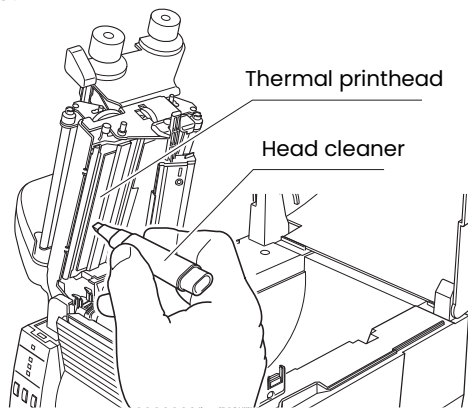

### Caution

Do not use any solvent other than ethyl alcohol. Solvents such as benzene, acetone and thinner will dissolve plastic parts and destroy the thermal printhead, platen and much of the printer! Try to avoid using "excessive amounts" of ethyl alcohol to clean the platen. Excessive use will harden the platen surface prematurely.

# Appendixes

## Troubleshooting

This section explains corrective actions taken when the printer malfunctions or when an error message is displayed.

### Items to check when a malfunction occurs

When the printer malfunctions during operation, take corrective action with reference to the following table. If the corrective action does not solve the problem, consult with the service personnel at the dealer where you purchased the printer.

*Connection to Power(P.17)*

*Cleaning(P.57)*

*Setting the Ribbon(P.33)*

Indication	Check	Corrective action
The LED do not light up when printer power is connected.	1) Is the plug of the power cord correctly inserted into the electric outlet?	1) Insert the plug of the power cord correctly in the electric outlet.
	2) Is the connector of the power cord correctly inserted into the power inlet of the printer?	2) Insert the connector of the power cord correctly into the power inlet of the printer.
	3) Is the power cord damaged?	3) Replace the power cord. Consult with the dealer where the printer was purchased to make sure you obtain a cord made especially for the printer. <b>Note:</b> Do not use any power cord except one made especially for the printer.
	4) Is power supplied to the electric outlet the printer is connected to?	4) Check to make sure power is supplied to the outlet. If there are any problems, make sure power is supplied to the building. Or find out if a power failure has occurred.
	5) Is the main fuse in the building's fuse box burnt out?	5) If necessary, replace the main fuse in the building's fuse box, and reset the main breaker. Ask a qualified serviceman to carry out the replacement.
Paper is feeding, but nothing is printed.	1) Is the thermal printhead dirty? Is a label stuck to the head?	1) If it is dirty, remove the dirt with the attached head cleaner. If a label is stuck to the thermal printhead remove it. <b>Note:</b> Do not use a metal object to remove a label stuck to the inside of the printer. (This may damage the thermal printhead.) If adhesive label material is stuck to the thermal printhead, remove it with a soft cloth soaked in ethyl alcohol.
	2) Is the recommended ribbon or a ribbon of the same type used?	2) Use the recommended ribbon or a ribbon of the same type.

# Appendixes

## Troubleshooting

*Loading roll media(P.23)*  
*Setting method(P.33)*  
*Menu Setting Table(P.42)*

*Cleaning(P.57)*

*Setting the Ribbon(P.33)*

*Media Thickness Adjustment(P.53)*

*Media Width Adjustment(P.54)*

*Loading roll media(P.23)*  
*Setting method(P.33)*  
*Cleaning(P.57)*

*LED Functions(P.21)*

*Menu Setting Table(P.42)*

Indication	Check	Corrective action
The printer is not printing neatly.	1) Are the media and the ribbon correctly set?	1) Correctly set the media and the ribbon.
	2) Is the printing density too high or too low?	2) Set the appropriate printing density using the menu or control software.
	3) Is the platen dirty? Is it deformed?	3) If it is dirty, clean it with ethyl alcohol. If it is deformed, replace it. <b>Note:</b> Consult with the dealer that supplied the printer concerning the replacement.
	4) Is the thermal printhead dirty? Is a label stuck to the head.	4) If it is dirty, remove the dirt with the attached head cleaner. If a label is stuck to the head, remove it. <b>Note:</b> Do not use a metal object to remove a label stuck to the inside of the printer. (This may damage the thermal printhead.) If adhesive label material is stuck to the print head, remove it with a soft cloth soaked in ethyl alcohol.
	5) Is the recommended ribbon or a ribbon of the same type used?	5) Use the recommended ribbon or a ribbon of the same type.
	6) Is the thermal printhead in the correct position for the media that is used?	6) Adjust the offset of the thermal printhead with the media thickness adjustment dial.
	7) Is the printer's head pressure balance correct for the width of the media that is used?	7) Adjust the thermal printhead pressure with the media width adjustment dial.
The printing position changes.	1) Are the media and the ribbon correctly set?	1) Correctly set the media and the ribbon.
	2) Is the platen dirty? Is it deformed?	2) If it is dirty, clean it with ethyl alcohol. If it is deformed, replace it. <b>Note:</b> Consult with the dealer that supplied the printer concerning the replacement.
	3) Are the data contents and the command signals from the host appropriate?	3) If an error message is displayed, check the content of the software and the communication status set by the host computer.
	4) Are the menu values set appropriately?	4) Set the correct menu values using the operating panel or the host computer.

# Appendixes

## Troubleshooting

*Ribbon Tension Adjustment(P.55)*

*Ribbon Balance Adjustment(P.56)*

*Ribbon Tension Adjustment(P.55)*

*Setting the Ribbon(P.33)*

Indication	Check	Corrective action
The printing position changes.	5) Are the sensitivities of the media sensors appropriate for the media that is used?	5) Set the media sensitivity to appropriate values. If this does not solve the problem, change the "Sensor level" that is set in the "System setup."
The ribbon is wrinkled	1) Is the ribbon tension suitable for the ribbon that is used?	1) Adjust the tension with the ribbon tension adjustment knob.
	2) Is the ribbon used correctly balanced to the right and left?	2) Adjust the left - right balance with the ribbon balance adjustment knob.
	3) Is the printing density too high?	3) Set the appropriate printing density using the menu or control software.
	4) Are the media and ribbon the recommended products or equivalent products?	4) Use the recommended products or equivalent products. If this does not correct the problem, contact a service representative.
The ribbon slips (ribbon dirt is produced.)	1) Is the ribbon tension suitable for the ribbon that is used?	1) Adjust the tension with the ribbon tension adjustment knob.
The ribbon does not wind.	1) Is the ribbon set in the correct course?	1) Set the ribbon in the correct course.
	2) Is the ribbon winding direction reversed?	2) Set the correct winding direction.

## Specifications

Item	Description			
Printing	Printing method	Thermal transfer/Direct thermal		
	Resolution	Main scanning line density: 203 dots/inch (8 dots/mm) (CL-S6621) 300 dots/inch (11.8 dots/mm) (CL-S6631)		
		Sub-scanning line density: 203 dots/inch (8 dots/mm) (CL-S6621) 300 dots/inch (11.8 dots/mm) (CL-S6631)		
		Head 1344 dots (printable dots: 1344 dots) (CL-S6621) 1984 dots (printable dots: 1984 dots) (CL-S6631)		
	Max. print width	168 mm	6.6 inch	
	Max. print length	2539.7mm (CL-S6621)	99.99 inch (CL-S6621)	
		1219.2mm (CL-S6631)	48.00 inch (CL-S6631)	
Print density	Print density is adjustable with software			
Printing speed	Printing speed setting	6, 5, 4, 3 or 2 inches per second (CL-S6621) 4, 3 or 2 inches per second (CL-S6631)		
	Batch mode	Normal printing (single or multiple sheets)		
Print mode	Tear off mode	Feeds back media to the tear-off position after printing is completed.		
	Cut mode <sup>*1</sup>	Prints while cutting at designated sheet units. The following two kinds of cut mode operations are done. • Backfeed • Cut through (Cut through refers to stopping present printing to cut the previous label when it reaches the cut position. After cutting, printing restarts but a gap may be created at the seam of the printing at this time.)		
	Peel mode <sup>*1</sup>	Peels labels from the liners after printing them.		
	Types of media	Roll, fanfold (continuous media, die-cuts, continuous tags, paper or tickets)		
Media <sup>*2</sup>	Recommended media	Thermal transfer: label media (LR1111 Lintec) Direct thermal media: label media (150LA-1 Ricoh), tag media (130LHB Ricoh)		
	Max. media width	178.0 mm	7.01 inch	
	Min. media width	50.0 mm	1.97 inch	
	Min. label width	50.0 mm	1.97 inch	
	Min. label pitch <sup>*3</sup>	19.0 mm	0.75 inch	
	Max. media thickness	0.254 mm	0.01 inch	
	Max. media length	2539.7mm (CL-S6621)	99.99 inch (CL-S6621)	
		1219.2mm (CL-S6631)	48.00 inch (CL-S6631)	
	Min. media length	16.0 mm	0.63 inch	
	Min. media thickness	0.0635 mm	0.0025 inch	
	On-board roll media diameter	Max. external diameter: 127 mm	5 inch	
		Media core: 25.4 to 76 mm Min. media core external diameter (when using label media): 50.8 mm	1 to 3 inch 2 inch	

# Appendixes

## Specifications

Item	Description		
Ribbon	Recommended ribbon	B110A Ricoh	
	Max. ribbon width	174.0 mm	6.85 inch
	Min. ribbon width	50.0 mm	1.97 inch
	Max. ribbon length	360.0 m	1,181 ft
	Max. roll diameter	74.0 mm	2.90 inch
	Inner diameter of the paper core	25.4 ± 0.25 mm	1.00 ± 0.01 inch
	Outer diameter of the paper core	33.4 ± 0.5 mm	1.31 ± 0.02 inch
	Ribbon end tape length	Max. 80.0 mm	3.15 inch
	Ribbon end detection	Ribbon out detection by a tension sensor	
Bar code (for Datamax emulation)	One-dimension	<ul style="list-style-type: none"> <li>• Code 3 of 9 • UPC-A • UPC-E • EAN-13 (JAN-13) • EAN-8 (JAN-8) • Interleaved 2 of 5 • Code 128 • HIBC (Modulus 43-used code 3 of 9) • Codabar (NW-7) • Int 2 of 5 (Modulus10-used Interleaved 2 of 5) • Plessey • Case Code • UPC 2DIG ADD • UPC 5DIG ADD • Code 93 • Telepen • ZIP • UCC/EAN128 • UCC/EAN128 (for K-MART) • UCC/EAN128 Random Weight • FIM</li> </ul>	
	Two-dimension	<ul style="list-style-type: none"> <li>• MaxiCode • PDF-417 • Data Matrix • QR Code*10 • Aztec • GS1 Databar Omnidirectional (RSS-14) • GS1 Databar Truncated (RSS-14 Truncated) • GS1 Databar Stacked (RSS-14 Stacked) • GS1 Databar Stacked Omnidirectional (RSS-14 Stacked Omnidirectional) • GS1 Databar Limited (RSS Limited) • GS1 Databar Expanded (RSS Expanded)</li> </ul>	
Bar code (for Zebra®*7 emulation)	One-dimension	<ul style="list-style-type: none"> <li>• Code 11 • Interleaved 2 of 5 • Code 39 • EAN-8 • UPC-E • Code 93 • Code 128 • EAN-13 • Industrial 2 of 5 • Standard 2 of 5 • ANSI CODABAR • LOGMARS • MSI • Plessey • UPC/EAN Extensions • UPC-A • POSTNET • Planet</li> </ul>	
	Two-dimension	<ul style="list-style-type: none"> <li>• Code 49 • PDF-417 • CODA BLOCK • MaxiCode • Micro PDF-417 • Data Matrix • QR Code*10 • TLC39 • Aztec • GS1 Databar Omnidirectional (RSS-14) • GS1 Databar Truncated (RSS-14 Truncated) • GS1 Databar Stacked (RSS-14 Stacked) • GS1 Databar Stacked Omnidirectional (RSS-14 Stacked Omnidirectional) • GS1 Databar Limited (RSS Limited) • GS1 Databar Expanded (RSS Expanded)</li> </ul>	
Bar code (for Eltron®*7 emulation)	One-dimension	<ul style="list-style-type: none"> <li>• Code39 • Code93 • Code128 • Codabar • EAN-8 • EAN-13 • German Postal Code • Interleaved2of5 • POSTNET • Planet • Japanese Postnet • UCC/EAN-128 • UPC-A • UPC-E • UPC-Interleaved2of5 • Plessey(MSI-1) • MSI-3</li> </ul>	
	Two-dimension	<ul style="list-style-type: none"> <li>• Aztec • Data Matrix • MaxiCode • PDF-417 • QR Code*10 • GS1 Databar Omnidirectional (RSS-14) • GS1 Databar Limited (RSS Limited) • GS1 Databar Stacked (RSS-14 Stacked) • GS1 Databar Truncated (RSS-14 Truncated)</li> </ul>	

# Appendixes

## Specifications

Item	Description								
Font (for Datamax emulation)	<ol style="list-style-type: none"> <li>Seven kinds of fixed pitch font <ul style="list-style-type: none"> <li>Overseas, English fonts and European fonts</li> </ul> </li> <li>OCR fonts OCR-A<sup>*4</sup>, OCR-B<sup>*4</sup></li> <li>Proportional fonts <ul style="list-style-type: none"> <li>CG Triumvirate smooth font</li> <li>CG Triumvirate Bold smooth font</li> <li>203dpi:(6, 8, 10, 12, 14, 18, 24, 30, 36, 48 points) (CL-S6621)</li> <li>300dpi:(4, 5, 6, 8, 10, 12, 14, 18, 24, 30, 36, 48 points) (CL-S6631)</li> <li>Character set: Conforms with code page 850 standards</li> </ul> </li> <li>True type™ rasterizer<sup>*5</sup></li> </ol>								
Font (for Zebra®*7 emulation)	<ol style="list-style-type: none"> <li>Five kinds of fixed pitch font <ul style="list-style-type: none"> <li>Overseas, English fonts and European fonts</li> </ul> </li> <li>OCR fonts <ul style="list-style-type: none"> <li>OCR-A<sup>*4</sup>, OCR-B<sup>*4</sup></li> </ul> </li> <li>Proportional font <ul style="list-style-type: none"> <li>CG Triumvirate Condensed Bold</li> </ul> </li> <li>True type™ rasterizer<sup>*5</sup></li> </ol>								
Font (for Eltron®*7 emulation)	<ol style="list-style-type: none"> <li>Five kinds of fixed pitch font <ul style="list-style-type: none"> <li>Overseas, English fonts and European fonts</li> </ul> </li> <li>Two kinds of fixed pitch font <ul style="list-style-type: none"> <li>Numbers only</li> </ul> </li> </ol>								
Symbol set	PC866U Ukraina*6, PC Cyrillic, ISO 60 Danish/Norwegian, DeskTop, ISO 8859/1 Latin 1, ISO 8859/2 Latin 2, ISO 8859/9 Latin 5, ISO 8859/10 Latin 6, ISO 8859/7 Latin/Greek, ISO 8859/15 Latin 9, ISO 8859/5 Latin/Cyrillic, ISO 69: French, ISO 21: German, ISO 15: Italian, Legal, Math-8, Macintosh, Math, PC-858 Multilingual, Microsoft Publishing, PC-8, Code Page 437, PC-8 D/N, Code Page 437N, PC-852 Latin 2, PC-851 Latin/Greek, PC-862 Latin/Hebrew, Pi Font, PC-850 Multilingual, PC-864 Latin/Arabic, PC-8 TK, Code Page 437T, PC-1004, PC-775 Baltic, Non-UGL, Generic Pi Font, Roman-8, Roman-9, ISO 17: Spanish, ISO 11: Swedish, Symbol, PS Text, ISO 4: United Kingdom, ISO 6: ASCII, Ventura International, Ventura Math, Ventura US, Windows 3.1 Latin 1, Wingdings, Windows 3.1 Latin 2, Windows 3.1 Baltic (Latv, Lith), Windows 3.0 Latin 1, Windows Latin/Cyrillic, Windows 3.1 Latin 5								
Control language	Supports the Datamax language, Zebra®*7 language and Eltron®*7 language								
Outline of electronic Devices	<table border="1"> <tr> <td>CPU</td> <td>32Bit RISC CPU</td> </tr> <tr> <td>ROM</td> <td>Standard equipment: FLASH ROM 16 Mbytes (User area: 4 Mbytes)</td> </tr> <tr> <td>RAM</td> <td>Standard equipment: SDRAM 32 Mbytes (User area: 4 Mbytes)</td> </tr> </table>	CPU	32Bit RISC CPU	ROM	Standard equipment: FLASH ROM 16 Mbytes (User area: 4 Mbytes)	RAM	Standard equipment: SDRAM 32 Mbytes (User area: 4 Mbytes)		
CPU	32Bit RISC CPU								
ROM	Standard equipment: FLASH ROM 16 Mbytes (User area: 4 Mbytes)								
RAM	Standard equipment: SDRAM 32 Mbytes (User area: 4 Mbytes)								
Media detection sensors	<table border="1"> <tr> <td>Label detection sensor (Transparent sensor)</td> <td>Detects media gap between labels, notches on tags, and media out</td> </tr> <tr> <td>Black mark detection sensor (Reflective sensor)</td> <td>Detects reflective mark on back of media and media out</td> </tr> <tr> <td>Label peeling sensor*1</td> <td>Detects labels that are peeled off</td> </tr> <tr> <td>Paper near end sensor</td> <td>Detects roll of media that is running out</td> </tr> </table>	Label detection sensor (Transparent sensor)	Detects media gap between labels, notches on tags, and media out	Black mark detection sensor (Reflective sensor)	Detects reflective mark on back of media and media out	Label peeling sensor*1	Detects labels that are peeled off	Paper near end sensor	Detects roll of media that is running out
Label detection sensor (Transparent sensor)	Detects media gap between labels, notches on tags, and media out								
Black mark detection sensor (Reflective sensor)	Detects reflective mark on back of media and media out								
Label peeling sensor*1	Detects labels that are peeled off								
Paper near end sensor	Detects roll of media that is running out								
Communication interfaces	<table border="1"> <tr> <td>Serial</td> <td>2400 4800 9600 19200 38400 57600 115200 bps</td> </tr> <tr> <td>USB</td> <td>High-Speed USB2.0</td> </tr> </table>	Serial	2400 4800 9600 19200 38400 57600 115200 bps	USB	High-Speed USB2.0				
Serial	2400 4800 9600 19200 38400 57600 115200 bps								
USB	High-Speed USB2.0								

# Appendixes

## Specifications

Item	Description		
Communication interface options	Parallel <sup>8</sup>	IEEE1284 (compatible, Nibble, ECP mode)	
	Wired LAN <sup>9</sup>	IF1-EFX1	Ethernet (100BASE-TX / 10BASE-T)
		IF1-EFX2	Ethernet (100BASE-TX / 10BASE-T) + High speed USB2.0×2
	Wired LAN/ Wireless LAN <sup>9</sup>	IF1-ES04	Ethernet (10BASE-T/100BASE-TX/1000BASE-T) + IEEE 802.11 b/g/n: 2.4GHz, IEEE 802.11 a/n/ac: 5GHz
		Wireless LAN <sup>9</sup>	IF1-WFX4
IF1-WFX5	IEEE802.11n, IEEE802.11a , IEEE802.11g, IEEE802.11b + Ethernet (10BASE-T/100BASE-TX/1000BASE-T) + High speed USB2.0×2		
Indications and switches	LED	POWER, PRINT, CONDITION, ERROR	
	Buzzer	Alarms, errors, etc.	
	Operating panel keys	PAUSE, FEED, STOP, MODE/REPEAT	
	Head-up detection sensor	Detects head open	
	Power switch	Turns power on and off	
	Acoustic noise	55 dB (by EN ISO7779)	
Power (standards)	220V-240V: 50/60Hz (Europe <sup>11</sup> , India <sup>11</sup> ) EN62368-1:2014/ A11:2017 <sup>11</sup> , EN55032:2012 classA <sup>11</sup> , EN55035:2017/A11:2020 <sup>11</sup> , EN61000-3-2:2014 <sup>11</sup> , EN61000-3-3:2013 <sup>11</sup> , EN50581:2012 (RoHS) <sup>11</sup> , IS13252(Part1):2010+A1:2013+A2:2015 <sup>11</sup>		
Environment	Operating temperature conditions:	<p>Operating temp. 0 to 40° C / 32 to 104°F, humidity 30 to 80%, condensation free (Conditions: ventilation, and natural convection)</p> <p>Legend:  <span style="display:inline-block; width:10px; height:10px; background-color:lightgray; border:1px solid black;"></span> Operating assurance temperature  <span style="display:inline-block; width:10px; height:10px; background-color:darkgray; border:1px solid black;"></span> Printing assurance temperature</p> <p>Humidity %</p> <p>0 5 35 40 Temperature °C</p> <p>Conditions assuring operation and printing</p>	
	Storage temperature conditions:	<p>Temp. -20 to 60 °C / -4 to 140°F, humidity 5 to 85 % (Conditions: ventilation, and natural convection) *However, for storage at high temperature and humid environments, the combination of 40°C / 104°F and 85% RH (no condensation) is taken as the worst value.</p>	

# Appendixes

## Specifications

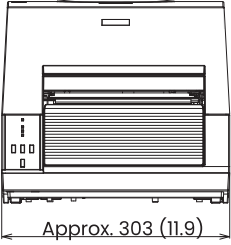
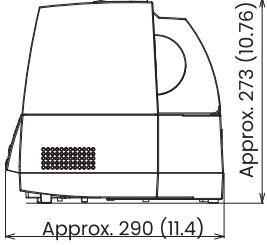
Item	Description
External dimensions*12	Approx. 303(W) × 290 (D) × 273 (H) mm 11.9(W) × 11.4 (D) × 10.76 (H) inch Unit: mm (inch) <div style="display: flex; justify-content: space-around; align-items: center;">   </div>
Weight	Approx. 7.9 kg (17.4 lb.)
Option	Auto-cutter unit, Peeler unit, IEEE1284 Parallel interface board, Ethernet interface board and wireless LAN interface board.

- \*1: Options can be separately purchased.
- \*2: If you wish to use other media than those recommended, please contact the shop where you bought this item.
- \*3: When a media pitch of less than 1 inch is used, activate the "Small Media Adjustment" setting in the "Page Setup."
- \*4: The OCR font may have a low recognition rate according to the reader.
- \*5: UFST™ and TrueType™ rasterizer are licensed from Monotype Imaging, Inc. UFST™ and CG Triumvirate™ are trademarks of Monotype Imaging, Inc. TrueType™ is a trademark of Apple Inc.
- \*6: "PC866U Ukraina" is available for Datamax emulation only.
- \*7: Zebra®, Eltron®, ZPL2™, and EPL2™ are registered trademarks of ZIH Corp., USA
- \*8: This interface is Non-L. P. S. (Limited Power Source).
- \*9: For details about this interface, refer to the separate manual.
- \*10: QR Code is a registered trademark of DENSO WAVE INCORPORATED.
- \*11: CL-S6621 only.
- \*12: Dimensions are design values. Actual dimensions may vary due to variance in manufacturing processes.

## Interfaces

This printer is connected to a computer and prints according to commands sent from the computer.

There are two methods of interface with a computer, and it can be connected to any equipment that supports these methods. You can also connect to the computer with parallel, Wired LAN and wireless LAN.

### Serial Interface

#### Specifications

System	Start/stop asynchronous duplex communication
Signal level	RS-232C
Baud rate	2400, 4800, 9600, 19200, 38400, 57600, 115200 bps
Bit length	7 Bit, 8 Bit
Stop bit	1 Bit, 2 Bit
Parity	Odd, even, none
Connector	D-SUB 25 PIN

#### Signal line and pin arrangement

Pin No.	Signal code	Signal name	Function
1	FG	Protective grounding	Protective grounding
2	TXD	Transmitted data	Signal line that transmits data from the printer to other devices
3	RXD	Received data	Signal line that transmits data from other devices to the printer
4	RTS	Transmission request	Signal line that becomes active when the printer can receive data
5	CTS	Able to transfer data	Signal line that becomes active when other devices can receive data from the printer
6	DSR	Data set relay	Signal line used by external devices to notify printer that they are ready to communicate
7	SGND	Signal line ground	Shows the ground level of the signal line
8-13	NC	-	Not used
14	VCC	+3.3V	(FACTORY USE ONLY)
15-19	NC	-	Not used
20	DTR	Data terminal relay	Signal line used by printer to notify external devices that printer is ready to communicate
21-24	NC	-	Not used

### XON/XOFF Protocol

#### Requirements to output X-ON code

- Communication is possible when the power is on.
- When the receive buffer has less than 128 bytes available, XOFF code is output, then the receive buffer has at least 1024 bytes available.

#### Requirements to output the X-OFF code

- When the receive buffer has less than 128 bytes available

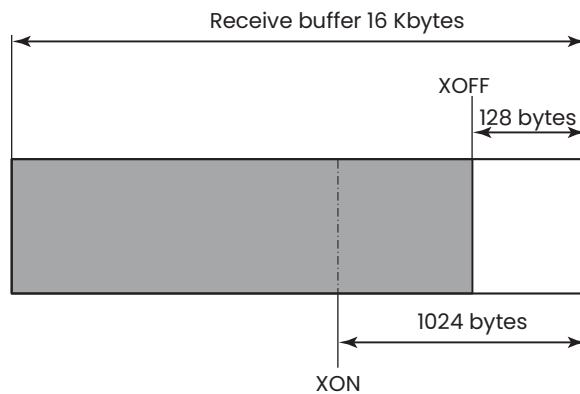

### DTR Protocol

#### Conditions when the DTR signal is "Ready (High)"

All the following conditions are satisfied.

- The receive buffer is 128 bytes or more available capacity.
  - \* When the receive buffer has less than 128 bytes available and the DTR signal has changed to BUSY (Low) status, BUSY status is maintained until the capacity of the receive buffer has reached 1024 bytes or more.

#### Conditions when DTR signal is "Busy (Low)"

- When the receive buffer has fallen to less than 128 bytes available.

## Interfaces

### USB Interface

#### Specifications

Standards	Complies with Universal Serial Bus Specification 2.0
Transmission speed	Compatible with 480Mbps (High-Speed) transmission
Receive buffer	16 Kbytes
Connector	15120-00410 (KST)

#### Signal line and pin arrangement

Pin No.	Signal code	Signal	Function
1	VBUS	USB power	USB power (+5V)
2	D-	Signal line -	- signal line
3	D+	Signal line +	+ signal line
4	GND	GND	GND

### Parallel Interface (Option)

#### Specifications

Transmission mode	8-bit parallel data
Receive buffer size	16 Kbytes
Transmission modes	<p><b>Compatible mode:</b> It is an asynchronous forward direction of the byte width (from host to printer) channel, and the interface line of the data is operated in accordance with signal line definitions of Centronics.</p> <p><b>NIBBLE mode:</b> Nibble mode is asynchronous reverse channel communication with data transmission controlled by the host computer. In reverse channel transmission, the data is nibble transmitted in two parts using four status lines (Fault, Select, PE, and Busy). And nibble mode can be used along with compatible mode to send data in two directions.</p> <p><b>ECP mode:</b> ECP mode permits bi-directional asynchronous data transmission, and thanks to its interlock handshake, it does not require the timing necessary with compatible mode.</p>
Signal level	IEEE1284 standard

#### Signal line and pin assignment table

Pin No.	Signal name	I/O	Function
1	*STROBE	Input	Strobe signal to read in 8-bit data
2-9	DATA1-8	Input	8-bit parallel signal
10	*ACKNLG	Output	8-bit data request signal
11	BUSY	Output	Signal specifying printer busy
12	PERROR	Output	Signal specifying media out
13	SELECT	Output	Signal specifying if the printer is on-line (printing enabled) or off-line (pausing)
14	AUTOFD	Input	Invalid (ignored)
15	NC	-	Not used
16	GND	-	Signal ground
17	FGND	-	Frame ground
18	P.L.H	Output	Peripheral logic high (pull up to +5 V at 1 k $\Omega$ )
19-30	GND	-	Ground for twisted pair return
31	*INIT	Input	Printer reset
32	*FAULT	Output	Signal specifying printer error
33-35	NC	-	Not used
36	SELECTIN	Input	Invalid (ignored)

### Parallel port status signals when an error occurs

The status of a signal line will not be changed in bi-directional mode such as nibble or ECP mode.

Error	Change in the status of a signal line in compatible mode
Paper end	Busy : L → H PError : L → H Select : H → L nFault : H → L
Error other than paper end •Head open •Other	Busy : L → H PError : L → unchanged Select : H → L nFault : H → L
Conditions for Busy	•Receive buffer full •Data being read •Error

### Compatible timing specification

[When power is on] (Time it goes off-line)

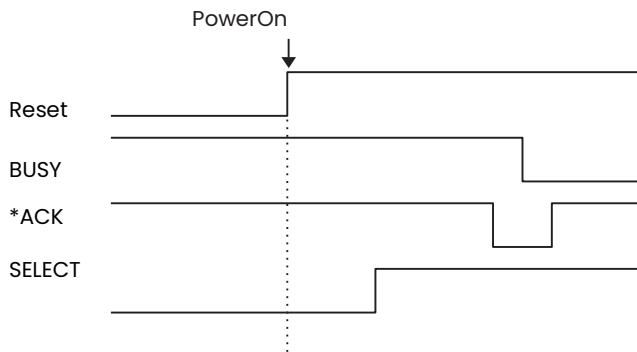

[While receiving data]

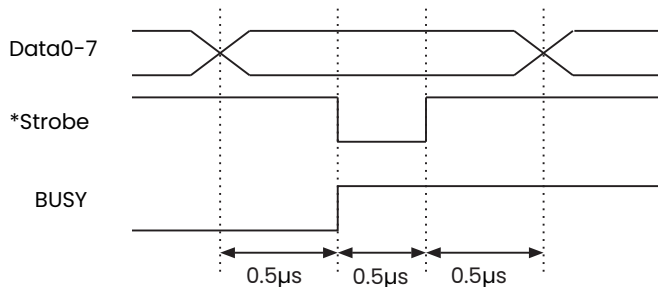

**Note:** Busy rises when \*Strobe signal starts, and data is latched with \*Strobe signal starts.

### [While receiving INIT signal]

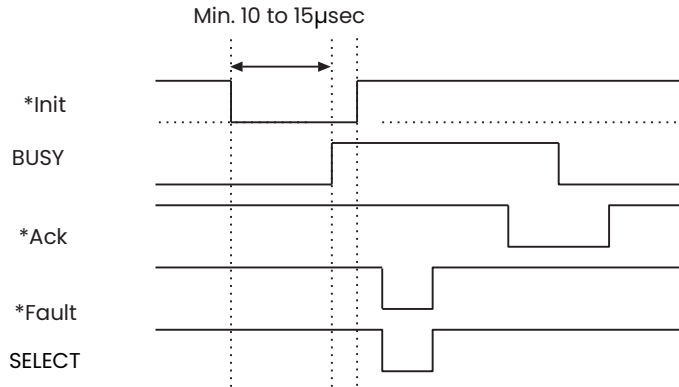

**Note:** If the \*Init signal does not have width of 10 to 15 μsec or more, it cannot act as an Init signal. If it is lower, the \*Init signal is ignored. BUSY starts up when the \*Init signal is perceived.

### Relation of the timing of the BUSY signal and the \*ACK signal

#### [Center - ACK]

